



TCLDM9

Temperature Controlled, Laser Diode
Mount for 5.6 and 9 mm LD

Operating Manual



Table of Contents

Part 1.	Description.....	3
Part 2.	Setup.....	4
2.1.	Laser Installation	4
2.2.	Laser Controller Connection	6
	Using the Thorlabs LDC Series Laser Controllers	6
	Using a Third-Party Laser Controller.....	6
2.3.	TEC Controller Connection.....	7
	Using the Thorlabs TED Series TEC Controllers	7
	Using a third-party TEC controller	7
2.4.	Mounting other Accessories	8
	Mounting Thorlabs Fiber Coupled Pigtailed Lasers	8
	The TEC Lockout and Ground Jumpers.....	9
2.5.	Making the Safety Interlock Connections.....	10
Part 3.	Operation.....	11
3.1.	RF Modulation	11
3.2.	Status and Interlocks	11
Part 4.	Maintaining the TCLDM9	13
Part 5.	Troubleshooting	14
Part 6.	Specifications	15
6.1.	Thermistor Data.....	16
Part 7.	Drawing.....	17
Part 8.	Regulatory	18
Part 9.	Thorlabs Worldwide Contacts	19

Part 1. Description

The TCLDM9 mount by Thorlabs is ideal for temperature-controlled operation of all 3 and 4-pin laser diodes in Ø9 mm (TO-18) and Ø5.6 mm (TO-46) packages. The mount can control the laser diode and monitor photodiode independently making it compatible with a wide variety of laser diodes including all three-pin style A, B, and C configuration laser diodes as well as all four-pin style D laser diodes. The mount is also compatible with all style E two-pin laser diodes (some style E configurations may require modifications to the mount).

Laser diodes can be quickly and easily changed in the mount. It is as simple as inserting the laser diode into the socket according to the imprinted pin assignment and fastening the clamp ring with two screws. The diode socket is located very close to the front of the cold plate making the connection of short lead devices easier. The pass-through design of the socket lets you install long lead diodes (up to 3/4") without trimming.

The TCLDM9 can be easily integrated into any existing optical setup. The bottom surface of the TCLDM9 provides 8-32 and M4 mounting holes, and its front plate is equipped with tapped holes to mount our 30 mm Cage System and SM1 threading for use with our Lens Tube Assemblies.

The TCLDM9 includes a Bias-T for RF modulation of the laser current up to 500 MHz. The mount can be adapted to the polarity of the laser diode and monitor diode by miniature switches located at the top of the mount. User protection features include an LED indicating an enabled laser located along the top of the mount and a remote interlock connector located on the side.

Laser protection features include optional grounding configurations, and the TEC Lockout circuit (only useable with our controllers) that prevents enabling the laser unless the TEC controller is active. The built-in TE cooler enables temperature-controlled operation of the laser diode. The clamp ring protects the laser diode against air drafts, thus temperature stabilities of about 10 mK can be achieved.

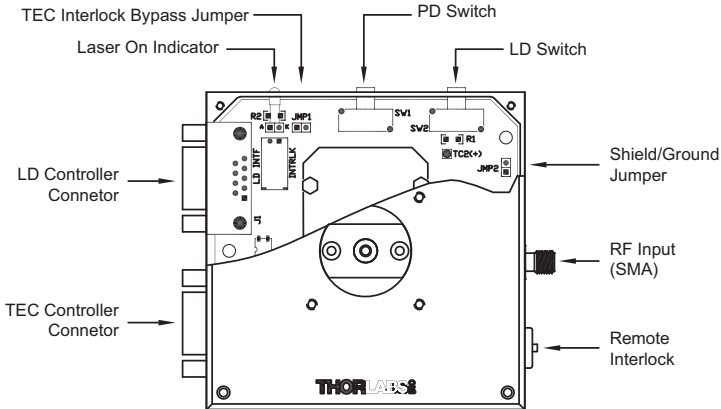

Figure 1: Location of Features

Part 2. Setup

2.1. Laser Installation

To install the laser diode, complete the following steps:

1. Unpack the laser mount and remove the four 2-56 socket head screws from the front cover using a 5/64" hex driver.
2. Remove the two Philips head 2-56 screws from the laser-mounting flange and remove the flange.
3. Determine the laser pin configuration from the laser diode manufacturer's data sheets and set the LD (Laser Diode) and PD (Photodiode) switches located on the top of the unit according to the figure below.

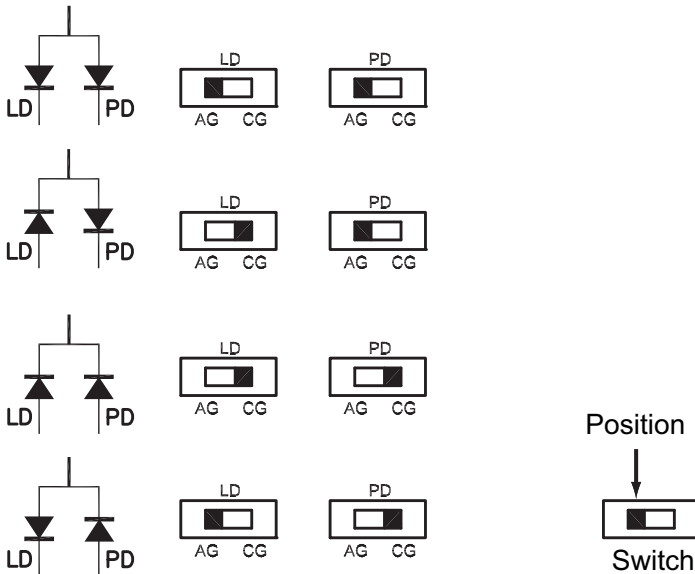

Figure 2: Polarity Switch Settings

4. Most laser diodes are three pins with the case tied to one of the laser pins and also to one of the photodiode pins. The other laser and photodiode pin will be isolated from the case. The TCLDM9 was designed to operate the laser case at ground potential therefore this common pin will be inserted into either the 12 o'clock or the 6 o'clock position of the laser connector. Locate the isolated laser pin and insert it in the 3 o'clock position. The isolated photodiode should now be in the 9 o'clock position. Refer to the figure below.

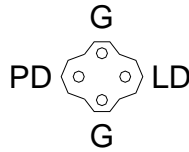

Figure 3: LD and PD Orientation

5. Replace the laser mounting flange and the cover. Install both screws through the mounting flange and loosely into the cold plate, then carefully tighten each screw a little bit at a time until the flange is just snug. Do not over tighten either screw – the flange will sit slightly above the cold plate. Reinstall the cover using the four 2-56 cap head screws provided.

Note: The four sockets comprising the laser diode connector are through hole type sockets with a blind clearance of 0.75" measured from the front face of the copper cold plate. It is not necessary to trim the laser diode leads prior to mounting into this connector unless they are longer than 0.75".

Note: The laser connector is located close enough to the front face of the copper cold plate to allow easy installation of short leaded lasers. The clearance area around the LD and PD sockets is sufficient to prevent the pins from contacting the cold plate.

Special Note for 4-pin Laser Diodes

The TCLDM9 also supports 4-pin laser diodes. Insert the laser into the 4-pin socket and note which laser pin is in the 3 o'clock position (laser anode or cathode). Also note which photodiode pin is in the 9 o'clock position (anode or cathode). The mount will tie the laser and photodiode pins located at 12 o'clock and 6 o'clock together and also to ground. By noting which polarity pins are inserted in the socket, you can convert the 4-pin layout to one of the 3-pin layouts in Figure 3 above. Set the LD and PD polarity switches accordingly.

2.2. Laser Controller Connection

Using the Thorlabs LDC/ITC Series Laser Controllers

- The TCLDM9 is compatible with all Thorlabs LDC LD controllers and ITC series combination controllers (LD and TEC). Appropriate cables with DB9 connectors are included with Thorlabs controllers and ensure that the controllers cannot be connected incorrectly. Additionally, these controllers have built-in protection circuitry that protects the laser when not in use.
- The nomenclature for the Laser Diode polarity switch on the LDC/ITC driver and the TCLDM9 are consistent with each other. For example, if the laser polarity on the driver is set to AG (anode grounded), then the LD polarity switch on the TCLDM9 should also be set to AG, and so forth.
- The nomenclature for the Photo Diode polarity switch on the LDC40xx/80xx and ITC series drivers and the TCLDM9 is as follows: The photodiode polarity switch on the TCLDM9 must always be set to “CG”. The photodiode polarity should be set with the internal Laser controller switch only. For more information on how to set Polarity settings on the Laser controller, please refer to the appropriate Laser Controller manual.

Using a Third-Party Laser Controller

When using a third-party controller, a custom cable will have to be made to properly interface to the laser mount. Please refer to the table below for laser connections.

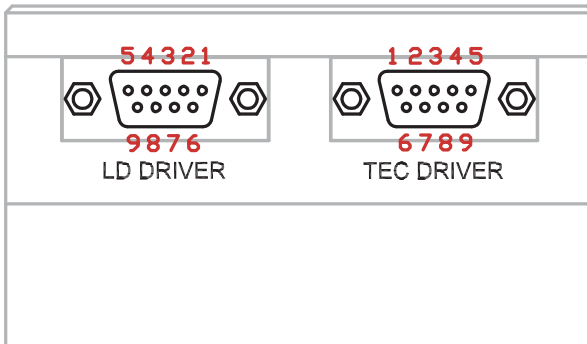

Figure 4: Pin Out for LD Driver and TEC Driver Connectors

Pin	Signal	Description
1	Interlock and Status Pin (LDC Specific)	This pin is the input to the LD Status Indicator and Interlock Circuits. When using Thorlabs LDCs no external circuitry is required. To use these features with third-party controllers please refer to the Status and Interlock section of this manual.
5	Interlock and Status Return	This pin is the return side of the Status and Interlock circuitry.
7	Laser Diode Cathode	This pin is connected to the 3 o'clock pin on the laser socket when the LD Polarity Switch is set to AG ¹ . Otherwise it is floating.
8	Laser Diode Anode	This pin is connected to the 3 o'clock pin on the laser socket when the LD Polarity Switch is set to CG ² . Otherwise it is floating.
3	Laser Ground (Case)	This pin is connected to the 12 o'clock and 6 o'clock pins on the laser socket and corresponds to the settings of the LD and PD polarity switches. i.e. If the LD and PD switches are set to AG then this pin grounds the Anodes of the laser and photo diodes.
2	Photodiode Cathode	This pin is connected to the 9 o'clock pin on the laser socket when the PD Polarity Switch is set to AG. It is attached to ground and the 12 o'clock and 6 o'clock pins on the laser socket when the PD Polarity Switch is set to CG.
4	Photodiode Anode	This pin is connected to the 9 o'clock pin on the laser socket when the PD Polarity Switch is set to CG. It is attached to ground and the 12 o'clock and 6 o'clock pins on the laser socket when the PD Polarity Switch is set to AG.
6	Laser Diode Voltage (Cathode)	This pin is connected to LD Interface Pin 7, thru a 499 Ω resistor, when the LD Polarity Switch is set to AG. It is attached directly to LD Interface Pin 3 when the LD Polarity Switch is set to CG.
9	Laser Diode Voltage (Anode)	This pin is connected to LD Interface Pin 8, thru a 499 Ω resistor, when the LD Polarity Switch is set to CG. It is attached directly to LD Interface Pin 3 when the LD Polarity Switch is set to AG.

2.3. TEC Controller Connection

Using the Thorlabs TED Series TEC Controllers

The TCLDM9 is best used with Thorlabs TED200 or related TEC Controllers. The TED series are shipped with a mating DB9 cable that plugs directly into the controller and laser mount. Using the cable supplied with the TED, the controller cannot be connected incorrectly. Simply connect the cable included with the TED to the Laser Mount and to the controller.

Using a third-party TEC controller

When using a third-party controller, a custom cable will have to be made to properly interface to the laser mount. Please refer to the table below for laser connections:

¹ AG stands for Anode Ground.

² CG stands for Cathode Ground.

Pin	Signal	Description
4	+TEC	This pin is connected to the positive terminal of the TEC element.
5	-TEC and TEC Lockout (-)	This pin is connected to the negative terminal of the TEC element, and also is common to the cathode of the photo-relay of the TEC Lockout circuit – refer to the Status and Interlock section of this manual.
1	TEC Lockout (+)	This pin is connected to the anode of the photo-relay side of the TEC Lockout circuit. When using Thorlabs TEDs no external circuitry is required. To use these features with third-party controllers please refer to the Status and Interlock section of this manual.
2	+Thermistor	The 10 k Ω at 25 $^{\circ}$ C NTC thermistor (provided for temperature feedback).
3	-Thermistor	The thermistor return pin.
7	AD592(-)	The negative terminal of the AD592 temperature transducer. When using Thorlabs TEDs no external circuitry is required. To use this device with third party controllers it must be properly biased. Refer to Analog Devices AD592 Data for application information.
9	AD592(+)	The positive terminal of the AD592
6	N.C.	Not used.
8	N.C.	Not Used.

2.4. Mounting other Accessories

The TCLDM9 includes an SM1 (1.035"-40) threaded hole centered on the laser for mounting our SM1 series of optics mounts. This is most often used for mounting aspheric collimating optics.

Also included are four 4-40 tapped holes mounted on 30 mm centers for attaching Thorlabs cage assembly products. Using the combination of the SM1 threaded mount and the cage assemblies' products, a wide variety of optical systems can be easily assembled form off-the-shelf products.

Mounting Thorlabs Fiber Coupled Pigtailed Lasers

Use the pigtail adapter clamp to hold the pigtail housing onto the TCLDM9 cold-plate, see figure 5 below.

1. First install the pigtailed laser into the TCLDM9 socket, observing the proper polarity of the laser to the socket (the pigtail's pin-outs are provided with the pigtail data sheet). If installed properly the flange of the pigtail will look as shown in figure 4a. It may be necessary to trim or remove the foam cold-plate insulator.
2. Make sure the pigtail's laser diode leads are fully inserted into the socket then slide the FC connector and optical fiber through the opening in the pigtail mounting adapter.
3. Slide the adapter over the pigtail housing, aligning the slot in the adapter with the flange on the pigtail housing (figure 5b). The mounting holes on the adapter should now be lined up with the threaded holes on the TCLDM9 cold-plate (figure 5c).

- Secure the adapter to the cold-plate using two (2) 2-56 x 3/8" cap head screws provide with the adapter. Start each screw into its respective mounting thread and tighten until just snug (do not over tighten), alternating between the two screws to ensure that the adapter is tightened evenly onto the Pigtail flange.

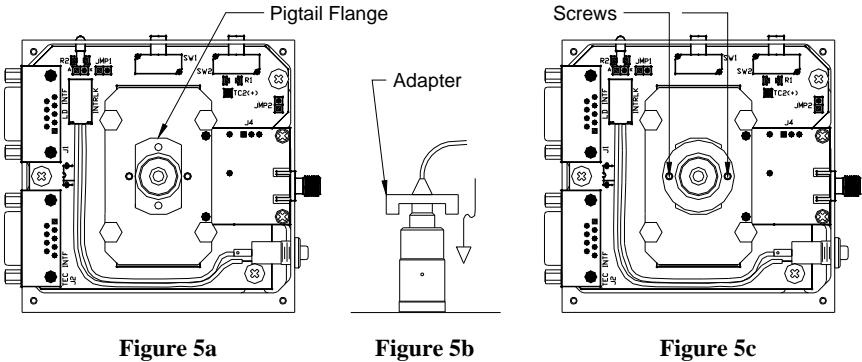

Figure 5: Installing Fiber Pigtailed Laser

The TEC Lockout and Ground Jumpers

Two jumpers, JMP1 and JMP2, are located under the cover on the main PCB assembly. JMP1 allows you to enable or bypass the TEC Lockout feature. This feature, when enabled, will prevent the laser diode from being turned on unless the TEC controller is enabled. The unit is shipped from the factory with the TEC lockout feature bypassed. To enable the TEC lockout, remove the cover of the unit and remove the blue jumper from the JMP1 header. The jumper can be placed on one or the other header pins for safekeeping.

An optional ground jumper is also provided to allow connecting the system ground node (common to the “G” pins of the laser diode connector) to the metal housing of the unit, which is also connected to the shields of the LD and TEC input cables. Care should be taken when using this connection as unwanted ground loops may be formed. The unit is shipped from the factory with JMP2 disconnected. To close this connection, remove the cover of the unit and place the blue jumper onto both pins of the JMP2 header. See figure 1 on page 3 for jumper locations.

2.5. Making the Safety Interlock Connections

The TCLDM9 is equipped with a Remote Interlock connector located on the side panel. In order to enable the laser source, a short circuit must be applied across the terminals of the remote interlock connector. In practice this connection is made available to allow the user to connect a remote actuated switch to the connector (i.e. an open door indicator). The switch (which must be normally open) has to be closed in order for the unit to be enabled. Once the switch is in an open state the laser diode must automatically shut down.

All units are shipped configured with a shorting device installed in the interlock connector. If you are not going to use this feature then you can leave the shorting device installed and the unit will operate normally as described in the procedures in this manual. If you wish to make use of the interlock feature you will need to acquire the appropriate connector mate and wire it your remote interlock switch. Next, remove the shorting device by pulling it from the input and install the connector into the interlock input.

The interlock input only accepts a 2.5 mm mono phono jack. This connector is readily available at most electronics suppliers.

The electrical specifications for the interlock input are as follows:

Specification	Value
Type of Mating Connector	2.5 mm mono phono jack
Open Circuit Voltage	+5 VDC with respect to system ground (when used in conjunction with Thorlabs drivers)
Short Circuit Current	10 mA DC Typical
Connector Polarity	Tip is positive, Barrel is ground
Interlock Switch Requirements	Must be N.O. dry contacts (under no circumstances should any external voltages be applied to the Interlock input)

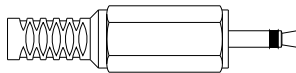

Figure 6: Remote Interlock Connector

Part 3. Operation

With the laser mounted and the laser controller and temperature controller connected, the TCLDM9 is ready to operate. Please refer to the operating instructions for the laser and temperature controller for specific operating instructions.

When operating at low temperatures in high humidity climates the laser mount may develop internal condensation. If this occurs, turn the laser off, open the case and allow the mount to dry off completely before re-using.

When using a collimating optic in the 1" threaded mount, the lens may be positioned slightly laterally by loosening the four 2-56 screws on the cover and shifting the cover plate manually.

3.1. RF Modulation

The TCLDM9 has an RF input for modulating the laser with an external RF source up to 500 MHz. This is a 50 Ω input that is AC-coupled directly to the laser through a Bias-Tee network. To calculate the desired RF power to modulate the laser determine the amount of modulating current needed from the laser manufacturer's data sheets and use the following calculations:

$$V_{RF} = 50 \Omega(\text{LD Modulating Current})$$

It is strongly recommended that you start off conservatively by a factor of 10 below the calculated modulating voltage and slowly bring the RF power up until the desired depth of modulation is reached. Use the laser controller to establish the DC operating point of the laser.



WARNING



The RF input is directly coupled to the laser. Any excessive transients or noise will be coupled into the laser and may cause the laser to be overdriven. In addition, the laser can be easily overdriven if excessive RF power is applied to this input. Use the RF modulation input with care to avoid damaging your laser.

3.2. Status and Interlocks

This unit is equipped with two interlock circuits and an LED that indicates if the laser diode is enabled. All three circuits are designed to interface with our laser and TEC controllers with no external circuitry.

If third party controllers are used to drive the laser diode or TEC elements then only the LD ON indicator can be used. To prevent damage to the Status and Interlock circuits the following external connections should be followed:

5. Install the shorting device into the REMOTE INTRLK connector that was shipped with the TCLDM9.
6. Install the TEC LOCKOUT bypass jumper into JMP1 inside the TCLDM9. (See “The TEC Lockout and GROUND Jumpers” above).
7. Connect a resistor to LD Interface DB9 Pin 1 appropriately sized to limit the current into Pin 1 to between 5 – 10mA.
8. The “driver” side of this resistor should be connected to a DC signal that, when high, indicates that the laser diode is being driven.
9. If you have any questions regarding these connections please feel free to contact an engineer at Thorlabs for clarification.

If you wish to make full use all of the status and interlock features with your third party drivers, please contact your local Tech Support office. An engineer will help you determine if this is possible and how to implement these features.

Part 4. Maintaining the TCLDM9

There are no serviceable parts in the TCLDM9. The housing may be cleaned by wiping with a soft damp cloth. If you suspect a problem with your TCLDM9 please call Thorlabs and an engineer will be happy to assist you.

Part 5. Troubleshooting

Problem	Solution
<p>Laser Driver will not enable. <i>(If you are using Thorlabs Laser and TEC controllers with your TCLDM9 mount.)</i></p>	<p>Remote Interlock is open. Make sure that either the “shorting device” is installed in the REMOTE INTRLK connector on the side of the TCLDM9. If you have a remote interlock switch connected to this REMOTE INTRLK connector it must be in a closed position.</p> <p>TEC LOCKOUT circuit is active and the TED series TEC controller is not enabled. To determine if you have selected the TEC LOCKOUT circuit to be active refer to The TEC Lockout and GROUND Jumpers section and Fig. 4. If it is selected then the TED series TEC controller must be enabled first before the LDC series laser controller can be enabled.</p>
<p>Laser wavelength or power is unstable even though the TEC controller shows a stable temperature.</p>	<p>Make sure your laser diode is fully inserted into the TCLDM9 laser socket and its body is in full contact with the copper cold plate.</p> <p>Make sure the appropriate mounting flange is installed over your laser. There are two different flanges; one specifically for 5.6mm diodes and one for 9mm diodes.</p>
<p>The LDC series laser driver indicates an “Open Circuit” alarm when the laser is enabled.</p>	<p>The LD and PD polarity switch settings are incorrect. Refer to Fig.2 and the data sheet for your specific laser diode to ensure the proper settings. The LD polarity switch setting on your TCLDM9 must also match the LD polarity switch setting on the rear panel of your LDC series laser diode controller.</p> <p>The laser diode is installed into the wrong pins on the laser diode socket. Refer to Fig. 3 for the correct orientation of the laser diode pins and compare this to the data sheet for your laser diode.</p>
<p>The LD does not have an integrated photodiode, how does it get installed and how do the polarity switches get set?</p>	<p>If your laser diode has one of its two active leads common to the case of the laser, that lead must be connected to one of the “G” sockets on the laser diode connector (refer to Fig. 3) while the other pin is connected to the “LD” socket in the 3 o’clock position. Depending on the pin orientation of your laser you might be using either the “G” socket at 12 o’clock or the “G” socket at 6 o’clock. Refer to your laser diode data for pin orientation. If your Cathode pin is common to the body of your laser diode, set the LD polarity switch to “CG”. If your Anode pin is common to the body of your laser diode, set the LD polarity switch to “AG”. The setting for the PD polarity switch is irrelevant.</p>

If you still have problems or questions regarding the operation of your TCLDM9 please feel free to contact your local Tech Support office.

Part 6. Specifications

Specification	Value
Laser Specs	
Lasers Supported	5.6 mm and 9 mm
Max. Laser Current	2 Amps
Laser Pin Configurations	A, B, C, D, and E LD Packages, Switch Selectable
RF Modulation Frequency	100 kHz to 500 MHz
RF Input Impedance	50Ω
Max RF Power	200 mW
Laser Polarity Select	External Slide Switches
Laser Interface	DB9 Female
TEC Specs	
Max TEC Current	5 A
Max TEC Voltage	4 V
TEC Heating / Cooling Capacity	20 W
Typical Temperature Range (LD dependent)	0 to 70 °C
Temp Sensors	AD592AN (1 μA/°K)
Thermistor	10 kΩ ± 3% at 25 °C, NTC Beta = 3977 K ± 0.75%
TEC Interface	DB9 Male
General	
Size	3.5" x 3.5" x 2"
Weight	1.3 lbs
Accessory Mounting	1.035-40 Thread for SM1 Series Mounts
Miscellaneous	4-40 Tapped Holes for 30 mm Cage System 8-32 and M4 Threaded Mounting Holes

6.1. Thermistor Data

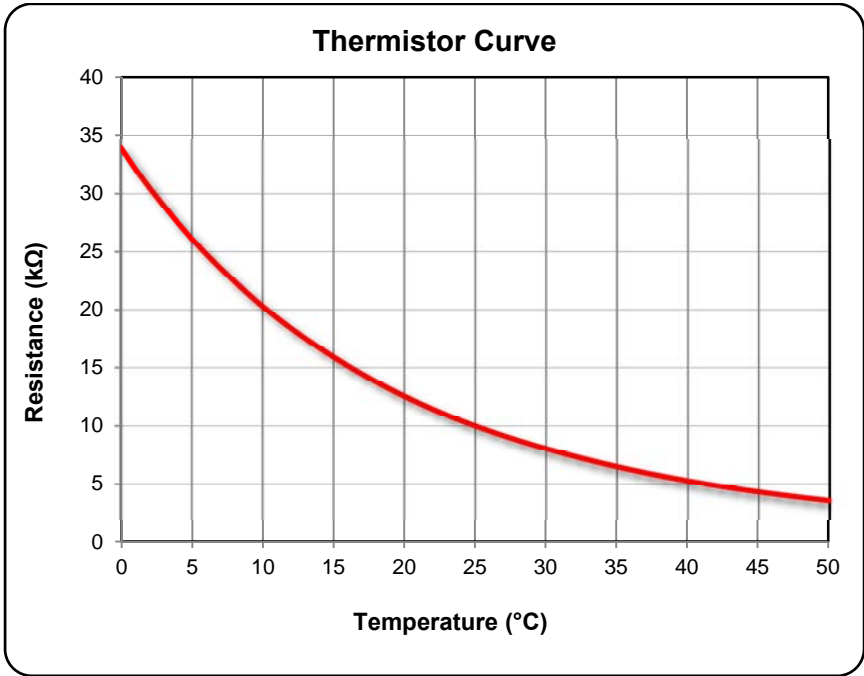
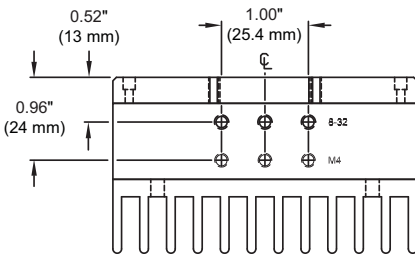
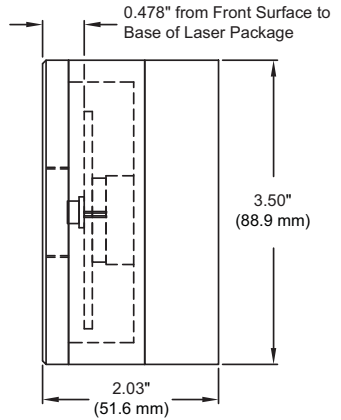
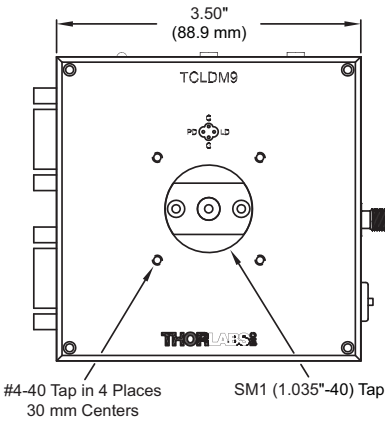
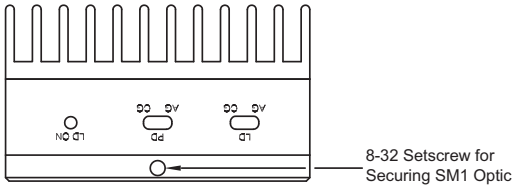

Figure 7: Thermistor Curve and Data

Resistance (Ohms)	Temperature (°C)	Resistance (Ohms)	Temperature (°C)
15895	15	9563	26
15153	16	9149	27
14451	17	8755	28
13785	18	8380	29
13155	19	8023	30
12558	20	7684	31
11991	21	7362	32
11454	22	7055	33
10944	23	6762	34
10460	24	6484	35
10000	25		

Part 7. Drawing



Part 8. Regulatory

As required by the WEEE (Waste Electrical and Electronic Equipment Directive) of the European Community and the corresponding national laws, Thorlabs offers all end users in the EC the possibility to return “end of life” units without incurring disposal charges.

- This offer is valid for Thorlabs electrical and electronic equipment:
- Sold after August 13, 2005
- Marked correspondingly with the crossed out “wheelie bin” logo (see right)
- Sold to a company or institute within the EC
- Currently owned by a company or institute within the EC
- Still complete, not disassembled and not contaminated



Wheelie Bin Logo

As the WEEE directive applies to self contained operational electrical and electronic products, this end of life take back service does not refer to other Thorlabs products, such as:

- Pure OEM products, that means assemblies to be built into a unit by the user (e.g. OEM laser driver cards)
- Components
- Mechanics and optics
- Left over parts of units disassembled by the user (PCB's, housings etc.).

If you wish to return a Thorlabs unit for waste recovery, please contact Thorlabs or your nearest dealer for further information.

8.1. Waste Treatment is Your Own Responsibility

If you do not return an “end of life” unit to Thorlabs, you must hand it to a company specialized in waste recovery. Do not dispose of the unit in a litter bin or at a public waste disposal site.

8.2. Ecological Background

It is well known that WEEE pollutes the environment by releasing toxic products during decomposition. The aim of the European RoHS directive is to reduce the content of toxic substances in electronic products in the future.

The intent of the WEEE directive is to enforce the recycling of WEEE. A controlled recycling of end of life products will thereby avoid negative impacts on the environment.

Part 9. Thorlabs Worldwide Contacts

USA, Canada, and South America

Thorlabs, Inc.
435 Route 206
Newton, NJ 07860
USA
Tel: 973-579-7227
Fax: 973-300-3600
www.thorlabs.com
email: feedback@thorlabs.com

Europe

Thorlabs GmbH
Hans-Böckler-Str. 6
85221 Dachau
Germany
Tel: +49-(0)8131-5956-0
Fax: +49-(0)8131-5956-99
www.thorlabs.de
email: Europe@thorlabs.com

France

Thorlabs SAS
109, rue des Côtes
78600 Maisons-Laffitte
France
Tel: +33 (0) 970 444 844
Fax: +33 (0) 811 381 748
www.thorlabs.de
email: slaes.fr@thorlabs.com

Japan

Thorlabs Japan Inc.
5-17-1, Ohtsuka
Bunkyo-ku, Tokyo 112-0012
Japan
Tel: +81-3-5979-8889
Fax: +81-3-5979-7285
www.thorlabs.jp
email: sales@thorlabs.jp

UK and Ireland

Thorlabs LTD.
1 Saint Thomas Place, Ely
Cambridgeshire CB7 4EX
Great Britain
Tel: +44 (0)1353-654440
Fax: +44 (0)1353-654444
www.thorlabs.de
email: sales.uk@thorlabs.com

Scandinavia

Thorlabs Sweden AB
Box 141 94
400 20 Göteborg
Sweden
Tel: +46-31-733-30-00
Fax: +46-31-703-40-45
www.thorlabs.de
email: scandinavia@thorlabs.com

China

Thorlabs China
Oasis Middlering Centre
3 Building 712 Room
915 Zhen Bei Road
Shanghai
China
Tel: +86 (0)21-32513486
Fax: +86 (0)21-32513480
www.thorlabs.com
email: chinasales@thorlabs.com



Thorlabs, Inc.
435 Route 206N
Newton, NJ 07860 USA

Phone: (973) 579-7227 ♦ Fax: (973) 300-3600
www.thorlabs.com
