



F/T Data Acquisition (DAQ)

Six-Axis Force/Torque Sensor System

Compilation of Manuals

The cover of the manual features the ATI logo at the top. Below it, the text reads: 'F/T Data Acquisition (DAQ)', 'Six-Axis Force/Torque Sensor System', and 'Installation and Operation Manual'. A photograph shows a laptop, a DAQ card, and a sensor. At the bottom, it says 'Manual #: 9620-05-DAQ' and 'Engineered Products for Robotic Productivity' with contact information.

**ATI INDUSTRIAL
AUTOMATION**
ISO 9001 Registered

F/T Data Acquisition (DAQ)

Six-Axis
Force/Torque Sensor System

Installation and Operation Manual



Manual #: 9620-05-DAQ

Engineered Products for Robotic Productivity
Pinnacle Park • 1031 Goodworth Drive • Apex, NC 27539 • Tel: +1-919-772-0115 • Fax: +1-919-772-8259 • www.ati-ia.com • Email: info@ati-ia.com

The cover of the manual features the ATI logo at the top. Below it, the text reads: 'F/T Transducer', 'Six-Axis Force/Torque Transducer', and 'Installation and Operation Manual'. A photograph shows several transducer units. At the bottom, it says 'Manual #: 9620-05-Transducer Section' and 'Engineered Products for Robotic Productivity' with contact information.

**ATI INDUSTRIAL
AUTOMATION**
ISO 9001 Registered

F/T Transducer

Six-Axis
Force/Torque Transducer

Installation and Operation Manual



Manual #: 9620-05-Transducer Section

Engineered Products for Robotic Productivity
Pinnacle Park • 1031 Goodworth Drive • Apex, NC 27539 USA • Tel: +1-919-772-0115 • Fax: +1-919-772-8259 • www.ati-ia.com • Email: info@ati-ia.com

Manual #: 9610-05-1017 DAQ

Engineered Products for Robotic Productivity

Pinnacle Park • 1031 Goodworth Drive • Apex, NC 27539 USA • Tel: +1-919.772.0115 • +1-919-772-8259 • www.ati-ia.com • Email: info@ati-ia.com



F/T Data Acquisition (DAQ)

Six-Axis

Force/Torque Sensor System

Installation and Operation Manual



Manual #: 9620-05-DAQ

April 2012

Engineered Products for Robotic Productivity

Pinnacle Park 1031 Goodworth Drive Apex, NC 27539 USA Tel: +1-919.772.0115 Fax: +1-919.772.8259 www.ati-ia.com Email: info@ati-ia.com

Forward

Information contained in this document is the property of ATI Industrial Automation, Inc. and shall not be reproduced in whole or in part without prior written approval of ATI Industrial Automation, Inc. The information herein is subject to change without notice and should not be construed as a commitment on the part of ATI Industrial Automation, Inc. This manual is periodically revised to reflect and incorporate changes made to the F/T system.

ATI Industrial Automation, Inc. assumes no responsibility for any errors or omissions in this document. Users' critical evaluation is welcome to assist in the preparation of future.

Copyright © by ATI Industrial Automation, Inc., Apex, North Carolina USA. All Rights Reserved.

Published in the USA.

In consideration that ATI Industrial Automation, Inc. (ATI) products are intended for use with robotic and/or automated machines, ATI does not recommend the use of its products for applications wherein failure or malfunction of a ATI component or system threatens life or makes injury probable. Anyone who uses or incorporates ATI components within any potentially life threatening system must obtain ATI's prior consent based upon assurance to ATI that a malfunction of ATI's component does not pose direct or indirect threat of injury or death, and (even if such consent is given) shall indemnify ATI from any claim, loss, liability, and related expenses arising from any injury or death resulting from use of ATI components.

All trademarks belong to their respective owners.

Windows, Visual Basic and Excel are registered trademarks of Microsoft Corporation.

LabVIEW is a registered trademark of National Instruments Corporation.

FCC Compliance - Class B

This device complies with Part 15 of the FCC Rules. Operation is subject to the following two conditions: 1) This device may not cause harmful interference, and 2) this device must accept any interference received, including interference that may cause undesired operation.

Any modifications to the device could impact compliance. It is the user's responsibility to certify the device remains compliant after modifications

CE Conformity



This device complies with EMC Directive 89/336/EEC and conforms to the following standards: EN5011:1998, ANSI C63.4:1992, ENG1000-4-2:1995, ENG1000-4-3:1995, ENG1000-4-6:1995.

Aside

Please read the manual before calling customer service. Before calling, have the following information available:

1. Serial number (e.g., FT01234)
2. Transducer model (e.g., Nano17, Gamma, Theta, etc.)
3. Calibration (e.g., US-15-50:5V, SI-65-5:10V, etc.)
4. Accurate and complete description of the question or problem
5. Computer and software information. Operating system, PC type, drivers, application software, and other relevant information about your configuration.

If possible be near the F/T system when calling.



CAUTION: Each transducer has a maximum measurement range and a maximum overload capacity. **Exceeding the transducer's overload capacity can cause permanent damage.** Smaller transducers have lower overload capacities. Tx and Ty are usually the easiest axes to accidentally overload.

Strain gage saturation is the first indication that you are approaching a mechanical overload condition, and saturation **always** causes inaccurate F/T data, so it is critical that you monitor the F/T system for strain gage saturation.

How to Reach Us

Sales, Service and Information about ATI products:

ATI Industrial Automation

1031 Goodworth Drive

Apex, NC 27539 USA

www.ati-ia.com

Tel: +1.919.772.0115

Fax: +1.919.772.8259

E-mail: info@ati-ia.com

Technical support and questions:

Application Engineering

Tel: +1.919.772.0115, Option 2, Option 1

Fax: +1.919.772.8259

E-mail: ft_support@ati-ia.com

Quick Start

Perform the following steps to get your system installed and running on your Windows® computer system. This Quick Start only applies to complete F/T systems that include a National Instruments DAQ card. For systems that do not include an NI DAQ card or otherwise require electrical custom connection or software, follow steps 1 through 5, then go to *Section 6.5.2—Custom DAQ Card Connects*.

Installing Data Acquisition Card

1. Install the National Instruments data acquisition hardware and software following the instructions included with the National Instruments product. When finished you should have installed the data acquisition hardware and the program *Measurement & Automation (MAX)*.

Installing ATI Software

2. Place the ATI Industrial Automation CD in your computer. The installation program should start automatically. If it does not start automatically, you will need to run *SETUP.EXE* found in the root directory of the CD. Follow the installation instructions given by the program. This software is for Windows® 95 and later Windows® operating systems.
3. View the *README.TXT* file found in the root directory of the CD.
4. Copy your transducer's calibration file from the CD directory *Calibration* to the *ATI DAQ FT* directory on your computer (this directory was created when you installed the software). The calibration file name is based on the transducer's serial number and is in the format *FTxxxx.CAL*.

Connecting Transducer Hardware

5. Connect the transducer to the Power Supply Box or Interface Box/Power Supply with the appropriate cable.
6. Connect the Power Supply Box or Power Supply/Interface Box to the data acquisition hardware using the supplied cable.
7. Run the demo program found in the Start menu under *Programs/ATI DAQ FT/ATI DAQ FT Demo*.
8. Click on the menu *File*, then *Open Calibration*. Find the calibration data file you saved earlier and click the *Open* button. Select the file with the name similar to *FTxxxx.CAL* and click on the *Open* button.
9. You can find program samples in the CD directory *SAMPLES*.

Please contact ATI for any information you may need for installation and configuration of your new system.



CAUTION: Each transducer has a maximum measurement range and a maximum overload capacity. **Exceeding the transducer's overload capacity can cause permanent damage.** Smaller transducers have lower overload capacities. Tx and Ty are usually the easiest axes to accidentally overload. When designing your application, it is critical that you monitor the F/T system for gage saturation to prevent an overload condition and to ensure accurate results.

Table of Contents

Forward	2
Quick Start	4
Table of Contents	5
Glossary of Terms	8
1. Safety	9
1.1 General	9
1.2 Explanation of Warnings	9
1.3 Precautions	9
2. Getting Started	10
2.1 Introduction	10
2.2 Unpacking	10
2.3 System Components Description	11
2.3.1 Transducer	11
2.3.2 Transducer Cable	11
2.3.3 Power Supply and Interface/Power Supply Boxes	12
2.3.4 Power Supply Cable	12
2.3.5 Data Acquisition System	12
2.3.6 F/T Software CD	12
2.3.7 Interface Plates	13
2.4 Connecting the System Components	13
2.4.1 Connecting the Transducer Cable	13
2.4.2 Installing the Data Acquisition Hardware	14
2.4.3 Connecting to the Data Acquisition Hardware	14
2.4.4 Testing with the ATI DAQ Demo on a Windows Computer	14
3. Installation	15
3.1 Introduction	15
3.2 Transducer and Cable Installation	15
4. How It Works	16
4.1 Introduction	16
4.2 Mechanical Description	16
4.3 Electronic Hardware	17
5. ATI DAQ Software	18
5.1 Reusable Software Components	18
5.1.1 ATI DAQFT Automation Server	18
5.1.2 C Library	18
5.2 Sample Applications	18
5.2.1 Windows Demo (Visual Basic 6.0)	18
5.2.2 LabVIEW Sample	18

- 5.3 Designing Your DAQ F/T Application19
 - 5.3.1 Device Drivers for Your DAQ Device and Target Operating System 19
 - 5.3.2 ATI DAQ F/T Components or C Library 19
- 6. Electrical Connection Information.....20**
 - 6.1 Signals and Power20
 - 6.2 Electrical Specifications21
 - 6.2.1 PS and IFPS box with transducer attached..... 21
 - 6.2.2 Transducer with On-board Interface Board 21
 - 6.2.3 Transducer Output Signals..... 21
 - 6.3 Transducer Signals21
 - 6.4 PS and IFPS Signals.....22
 - 6.4.1 PS 20-pin Circular Connector..... 22
 - 6.4.2 PS and IFPS 26-pin High Density D-Subminiature Connector..... 22
 - 6.5 DAQ Card Connections.....24
 - 6.5.1 Standard DAQ Card Connections 24
 - 6.5.2 Custom DAQ Card Connects 24
 - 6.6 Using Unused DAQ Card Resources.....26
- 7. Advanced Topics27**
 - 7.1 Writing DAQ F/T Application27
 - 7.2 Data Collection Rates27
 - 7.3 Multiple Calibrations27
 - 7.4 Detecting Failures (Diagnostics)27
 - 7.4.1 Detecting Connection Issues..... 27
 - 7.4.2 Detecting Cable Problems..... 27
 - 7.4.3 Detecting Sensitivity Changes..... 28
 - 7.5 Scheduled Maintenance.....28
 - 7.5.1 Periodic Inspection 28
 - 7.5.2 Periodic Calibration 28
 - 7.6 A Word about Resolution28
 - 7.7 Environmental29
- 8. Troubleshooting30**
 - 8.1 Introduction30
 - 8.2 Questions and Answers31
 - 8.2.1 Errors with force and torque readings 31
- 9. Appendix A—Multiple IFPS Boxes32**
 - 9.1 9105-IFPSMC Boxes32
 - 9.1.1 Transducer Connections 32
 - 9.1.2 Power 34
 - 9.1.3 Recalibration..... 35
 - 9.1.3.1 Removing the IFPS Card35
 - 9.1.3.2 Reinstalling an IFPS Card37
 - 9.2 Legacy 9105-IFPSM and 9105-IFPS Boxes37
 - 9.2.1 9105-IFPSM-3 and 9105-IFPSM-3E Signal Allocation..... 39

9.2.2	9105-IFPSM-4 and 9105-IFPSM-4E Signal Allocation.....	40
9.2.3	9105-IFPSM-5 and 9105-IFPSM-5E Signal Allocation.....	41
9.2.4	9105-IFPSM-6 and 9105-IFPSM-6E Signal Allocation.....	42
9.2.5	9105-IFPS-2 and 9105-IFPS-2-E Signal Allocation.....	43
9.2.6	9105-IFPS-3 and 9105-IFPS-3-E Signal Allocation.....	44
9.2.7	9105-IFPS-4 Signal Allocation.....	45
9.2.8	9105-IFPS-5 and 9105-IFPS-5-E Signal Allocation.....	46
9.2.9	9105-IFPS-6 and 9105-IFPS-6-E Signal Allocation.....	47
9.2.10	9105-IFPS-7 and 9105-IFPS-7-E Signal Allocation.....	48
9.2.11	9105-IFPS-8 Signal Allocation.....	49
10.	Appendix B—Drawings	50
10.1	9105-PS-1	50
10.2	9105-IFPS-1	51
10.3	9105-IFPSMC Multiple IFPS Box.....	52
10.4	Multiple IFPS.....	53
11.	Terms and Conditions of Sale	54

Glossary of Terms

Terms	Conditions
Accuracy	See <i>Measurement Uncertainty</i> .
ActiveX Component	A reusable software component for the Windows applications.
Calibration File	A computer file containing transducer calibration information. This file must match the transducer serial number and is required for operation.
Compound Loading	Any load that is not purely in one axis.
DAQ	D ata A c Q uisition device.
FS	F ull- S cale.
F/T	F orce and T orque.
Fxy	The resultant force vector comprised of components Fx and Fy.
Hysteresis	A source of measurement caused by the residual effects of previously applied loads.
IFPS	I nter F ace/ P ower S upply box.
LabVIEW	A graphical programming environment created for data acquisition tasks by National Instruments.
Manual Calculations	Programmatically calculating force and torque values without using the ATI DAQ F/T component.
MAP	M ounting A dapter P late. The MAP part of the transducer is attached to the fixed surface or robot arm.
Maximum Single-Axis Overload	The largest amount of pure load (not compound loading) that the transducer can withstand without damage.
Measurement Uncertainty	The maximum expected error in measurements, as specified on the calibration certificate.
NI	N ational Instruments Corporation, the owner of the “National Instruments” and “LabVIEW” trademarks. (www.ni.com)
Overload	The condition where more load is applied to the transducer than it can measure. This will result in saturation.
PC Card	A small computer card for use in most laptop computers.
PCMCIA Card	See <i>PC Card</i> . (PCMCIA has been renamed <i>PC Card</i> by its standards organization.)
Point of Origin	The point on the transducer from which all forces and torques are measured.
PS	P ower S upply box.
Quantization	The way the continuously variable transducer signal is converted into discrete digital values. Usually used when describing the change from one digital value to the next.
Resolution	The smallest change in load that can be measured. This is usually much smaller than accuracy.
Saturation	The condition where the transducer or data acquisition hardware has a load or signal outside of its sensing range.
Sensor System	The entire assembly consisting of parts from transducer to data acquisition card.
TAP	T ool A dapter P late. The TAP part of the transducer is attached to the load that is to be measured.
Tool Transformation	Mathematically changing the measurement coordinate system by translating the origin and/or rotating the axes.
Transducer	The component that converts the sensed load into electrical signals.
Txy	The resultant torque vector comprised of components Tx and Ty.
Visual Basic	A Microsoft programming environment for developing Windows-based applications.

1. Safety

1.1 General

The customer should verify that the transducer selected is rated for the maximum loads and moments expected during operation. Refer to transducer specifications in F/T Transducer Manual (9620-05-Transducer Section—Installation, Operation, and Specification Manual) or contact ATI for assistance. Particular attention should be paid to dynamic loads caused by robot acceleration and deceleration. These forces can be many times the value of static forces in high acceleration or deceleration situations.

1.2 Explanation of Warnings

The warnings included here are specific to the product(s) covered by this manual. It is expected that the user heed all warnings from the robot manufacturer and/or the manufacturers of other components used in the installation.



Danger indicates that a situation could result in potentially serious injury or damage to equipment.



Caution indicates that a situation could result in damage to the product and/or the other system components.

1.3 Precautions



DANGER: Do not attempt to disassemble the transducer. This will damage the instrumentation.



DANGER: Do not probe any openings in the transducer. This will damage the instrumentation.



DANGER: Take care to prevent excessive forces or moments from being applied to the transducer during handling or installation. The small Nano series is easily overloaded during rough handling and may be damaged.

2. Getting Started

2.1 Introduction

This section gives instructions for electrical and computer set up of the F/T system. After setting up the system, a test is performed to check for problems. Transducer installation is covered in *9620-05-Transducer Section—Installation, Operation, and Specification Manual*.



CAUTION: The Force/Torque transducer, the calibration data loaded on the CD and the IFPS box, if applicable, has been assigned matching serial numbers when the system was calibrated. If these serial numbers assigned to your F/T system do not match, the force and torque outputs will be incorrect. Do not mix system components from different systems.

2.2 Unpacking

- Check the shipping container and components for damage due to shipping. Any damage should be reported to ATI Industrial Automation.
- Check the packing list for omissions.
- The following are standard components for an F/T system (If you will be using your own data acquisition system, you may not receive all the items.):
 - Transducer
 - Transducer cable (for 9105-TIF transducers)
 - Power Supply or Interface Power Supply Box
 - Power Supply cable
 - Data Acquisition Card and its CD – if ordered
 - ATI CD containing software, calibration documents, and manuals.



CAUTION: The transducer, Power Supply box, Interface Power Supply box, and DAQ card are susceptible to damage from electrostatic discharge whenever they are not connected to a plugged-in computer. Do not touch the electronics or the connector pins when handling the transducer.

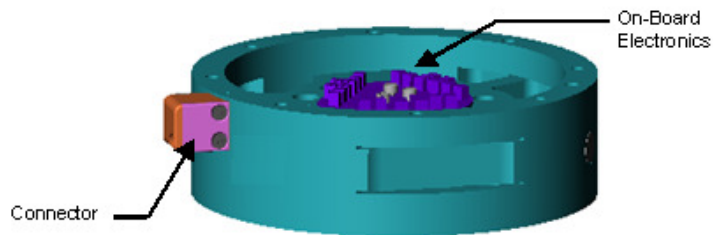

2.3 System Components Description

2.3.1 Transducer

The transducer is a compact, rugged, monolithic structure that converts force and torque into analog strain gage signals. The transducer is commonly used as a wrist sensor mounted between a robot and a robot end-effector. *Figure 2.1* shows the transducer with a standard tool adapter.

For further information not in this section, see:

- *9620-05-Transducer Section— Installation, Operation, and Specification Manual*, for mounting, cable routing, specifications (i.e., resolution, weight), and mechanical drawings.

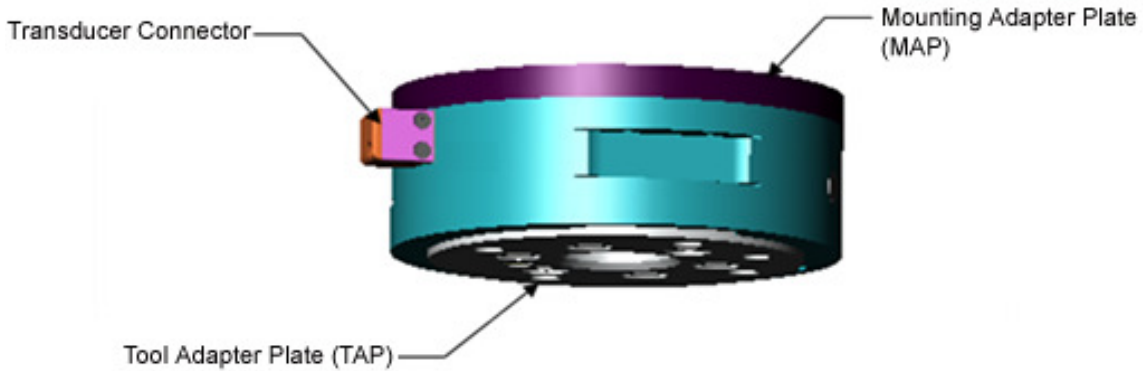

Figure 2.1—Transducer

Aside:

The transducer is designed to withstand extremely high overloading through its use of strong materials and quality silicon strain gages.

2.3.2 Transducer Cable

The high-flex life transducer cable is electrically shielded to protect transmission from the transducer Power Supply or Interface Power Supply boxes, small transducers have the cable integrally attached. Larger transducers have a separate cable [See *Figure 2.2*].

For further information not in this section, see:

- *9620-05-Transducer Section— Installation, Operation, and Specification Manual* for cable routing.



Figure 2.2a—Transducer Cable for 9105-TIF Transducers



Figure 2.2b—Integral Transducer Cable on Small Transducers

2.3.3 Power Supply and Interface/Power Supply Boxes

The Interface Power Supply box is typically used with the small Nano and Mini transducers. It supplies power to the transducer and electronics, as well as conditioning the transducer signals to be used with a data acquisition system. The transducer's 12-pin cable plugs into this box. The Power Supply box is used with larger transducers that have on-board interface electronics. The 20-pin transducer cable plugs into this box.

2.3.4 Power Supply Cable

The robust power supply cable connects the Power Supply box or Interface Power Supply box to the data acquisition system. This cable usually has a connector on the data acquisition end, but is also available unterminated.

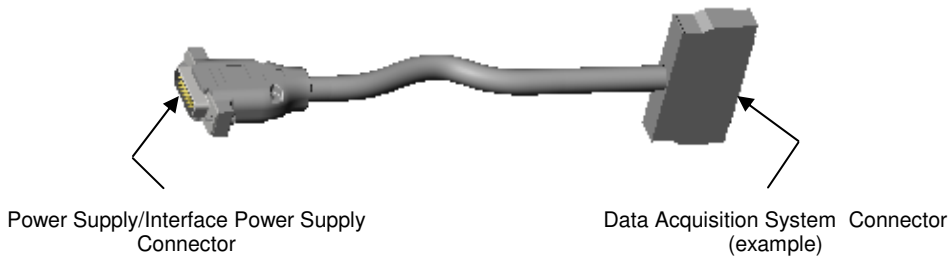

Figure 2.3—Power Supply Cable

2.3.5 Data Acquisition System

The data acquisition system converts the transducer signals from analog voltages into data your computer can use. This data needs to be processed by ATI software to become force and torque values. The data acquisition system also supplies raw power to the transducer system.

2.3.6 F/T Software CD

The F/T software CD contains the software and calibration data that your computer uses to convert the transducer readings into usable force and torque output. It also has Microsoft Windows drivers, sample programs, C source code, and detailed help files. The most recent release of the DAQ software can be found at <http://www.ati-ia.com/download/software.htm> on the web.

Aside:

The CD included with the DAQ system contains extensive help files on its software that will benefit both the beginner and the advanced user. The CD even includes a spreadsheet to help advanced users with calculations, see the *Advanced Techniques* section of the help file for more information.

2.3.7 Interface Plates

The larger transducers come with a standard mounting adapter to mechanically attach the transducer to your robot arm or apparatus that will be applying the force. The transducer also has a standard tool adapter with an ISO 9409-1 interface for Gamma, Delta, and Theta models for attaching your tool.

The mounting adapter consists of:

- Mounting adapter plate
- Mounting screws.

For further information not in this section, see:

- *9620-05-Transducer Section—Installation, Operation, and Specification Manual* for specifications (i.e., resolution, weight) and mechanical drawings.

2.4 Connecting the System Components

2.4.1 Connecting the Transducer Cable

Large DAQ F/T transducers connect to the system through a high-density 20-pin connector (see *Figure 2.4*). The Nano and Mini F/Ts have integral cables.

Connect the transducer cable connector to the transducer as follows:

- Lightly place the connector into port on the transducer. Do not push.
- Line up the groove on the connector to the key in the port by rotating the connector while lightly forcing the connector into the port. When the groove lines up the connector will go noticeably deeper into the port.
- Screw the connector shell into the transducer until it seats firmly.

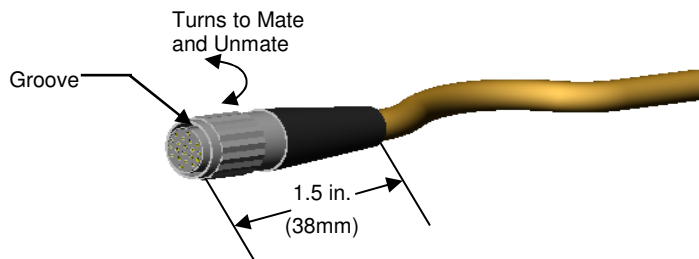

Figure 2.4—Transducer Connector

Disconnect the transducer connector from the transducer port by unscrewing the connector shell.



CAUTION: Cables on the Nano and Mini transducers are permanently attached to the transducer and can not be disconnected. Do not attempt to disassemble these transducers as **damage will occur**.

2.4.2 Installing the Data Acquisition Hardware

Install the data acquisition hardware and its accompanying software following the instructions included with the hardware.

2.4.3 Connecting to the Data Acquisition Hardware

If you are using a NI PCMCIA (a small PC card for laptop computers), you will need to attach the short adapter cable to the card. The other end of the adapter cable connects to the F/T Power Supply cable.

Connect the 26-pin, D-subminiature connector side of the Power Supply cable to the Power Supply or Interface Power Supply box. Tighten the jackscrews on the connector to insure a good electrical connection.

Connect the 68-pin connector side of the Power Supply cable to the NI data acquisition hardware. Tighten the jackscrews on the connector to insure a good electrical connection. Please note that some PCMCIA adapters do not use the jackscrews. In this case, you must insure the connectors do not get pulled apart.

Aside:

If you are not using a National Instruments DAQ board with mass termination, you will have to provide your own connector at that end of the cable. See *Section 6—Electrical Connection Information* for connection information.

2.4.4 Testing with the ATI DAQ Demo on a Windows Computer

Install the F/T software by inserting the CD in your computer. The installation program should start automatically. If it does not start automatically, you will need to run *SETUP.EXE* found in the root directory of the CD. Follow the installation instructions given by the program.

View the *README.TXT* file found in the root directory of the CD.

Copy your transducer's calibration file(s) from the CD directory *\Calibration* to the program directory *ATI DAQ FT*. Calibration file names are based on the transducer's serial number and are in the format of *FTxxx.CAL*. There will be multiple calibration files if the system was ordered with more than one calibration.

Run the demo program found in the Start Menu under *Programs\ATI DAQ FT\ATI DAQ FT Demo*. In the program, you must load the calibration data. Do this by clicking on the menu *File*, then *Open Calibration*. Find the calibration data file you saved earlier and click the *Open* button. At this point, the program should be displaying two sets of bar graphs; one labeled *Force* and the other labeled *Torque*. The center bottom of the demo window will show the transducer model and calibration for the loaded calibration file.

Gently apply load to the transducer without over-ranging the transducer. You should see the bar graphs respond.

Aside:

The ATI DAQ demo only works in conjunction with National Instruments DAQ boards.

3. Installation

3.1 Introduction

Proper installation of your transducer, its cabling, IFPS, or PS box, and data acquisition hardware is essential to proper operation.

3.2 Transducer and Cable Installation

See ATI Industrial Automation manual *9620-05-Transducer Section—Installation, Operation, and Specification Manual* for installation information

4. How It Works

4.1 Introduction

This section provides a functional outline of the F/T system. The F/T system is broken into three areas: Electrical, controlling software, and mechanical. A mechanical description is shown in *Section 4.2—Mechanical Description*. A graphical representation of the electronics and software is presented in *Section 4.3—Electronic Hardware*.

4.2 Mechanical Description

The property of forces was first stated by Newton in his third law of motion: *For every action there is always an opposed or equal reaction; or, the mutual action of two bodies upon each other are always equal, and directed to contrary parts*. The transducer reacts to applied forces and torques using Newton’s third law.

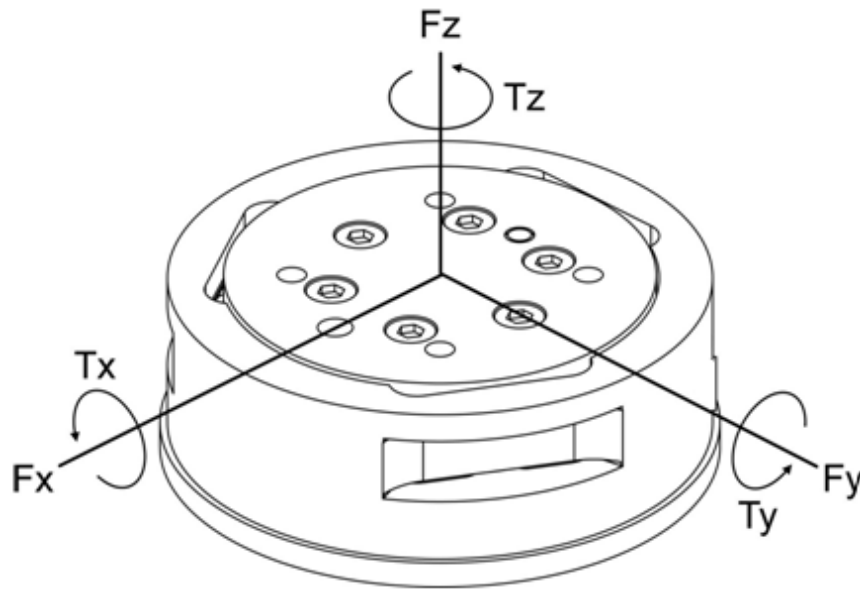

Figure 4.1—Applied Force and Torque Vector on Transducer

The force applied to the transducer flexes three symmetrically placed beams using Hooke’s law:

$$\sigma = E \cdot \epsilon$$

σ = Stress applied to the beam (σ is proportional to force)
 E = Elasticity modulus of the beam
 ϵ = Strain applied to the beam

Aside:

The transducer is a monolithic structure. The beams are machined from a solid piece of metal. This decreases hysteresis and increases the strength and repeatability of the structure.

Semiconductor strain gages are attached to the beams and are considered strain-sensitive resistors. The resistance of the strain gage changes as a function of the applied strain as follows:

$$\Delta R = S_a \cdot R_0 \cdot \epsilon$$

ΔR = Change in resistance of strain gage
 S_a = Gage factor of strain gage
 R_0 = Resistance of strain gage unstrained
 ϵ = Strain applied to strain gage

The electronic hardware, described in *Section 4.3—Electronic Hardware*, measures the change in resistance and the software, described in *Section 5—ATI DAQ Software*, converts this change to force and torque components.

4.3 Electronic Hardware

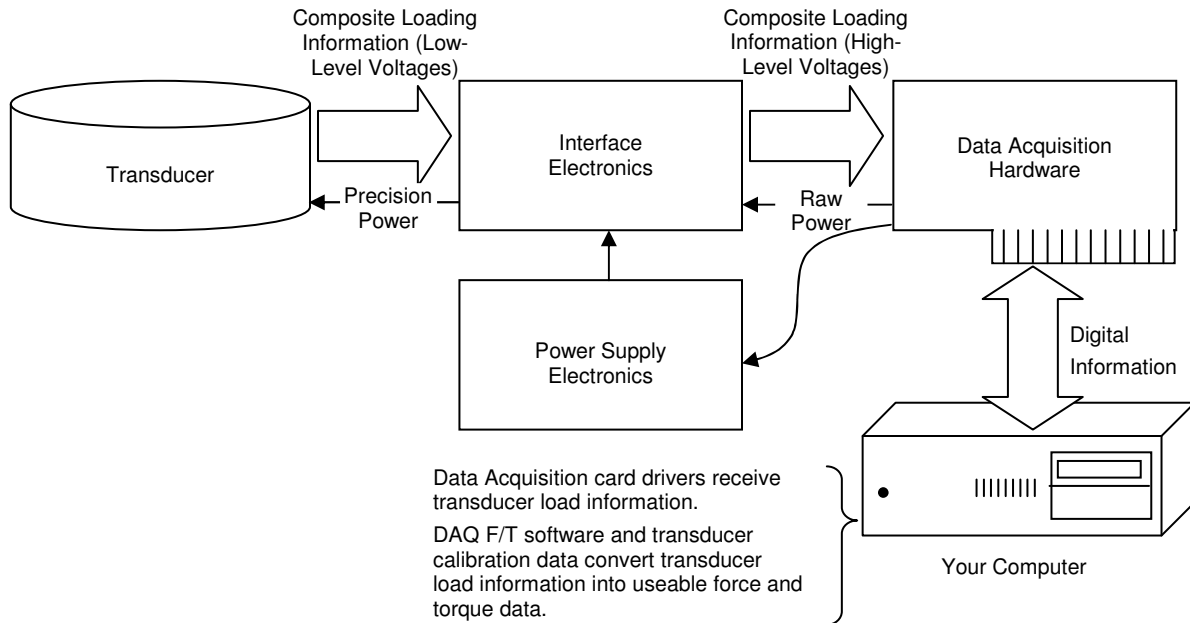

Figure 4.2—Electronic Hardware Outline

5. ATI DAQ Software

The computer that you connect your F/T system's data acquisition card to performs the important functions of converting the data acquisition card data into useful force and torque values and making these values available for use to you.

The ATI DAQ F/T Software CD contains reusable software components that you can use to build your application, as well as sample applications to get you started. (Unless otherwise noted, all Windows components and applications support Windows 95, 98, Me, NT, 2000, and XP.)

Aside:

The ATI DAQ F/T software CD contains extensive documentation on its software. Check this documentation for detailed help. CD updates can be found at http://www.ati-ia.com/download/DAQ_FT/DAQ%20FT%20Software.htm.

5.1 Reusable Software Components

5.1.1 ATI DAQFT Automation Server

This Windows ActiveX component reads calibration files, configures the transducer system, and converts raw voltages from any data acquisition system into forces and torques. ATIDAQFT can be used in development platforms that support ActiveX or Automation containment, including Microsoft Visual Basic 6.0, Microsoft Visual C++, Microsoft.NET Platform, National Instruments LabVIEW, and many others. Its programming API is documented in the ATIDAQFT help files.

5.1.2 C Library

This code library uses standard ANSI C to read calibration files, configure the transducer system, and convert voltage data from any data acquisition system into forces and torques.

5.2 Sample Applications

5.2.1 Windows Demo (Visual Basic 6.0)

This executable program is a good place to try out your new transducer system in Windows. It uses National Instruments software and ATIDAQFT to give a real-time display of F/T data from National Instruments devices. It provides complete options for configuration of the F/T system. Microsoft Visual Basic 6.0 source is included.

5.2.2 LabVIEW Sample

This is a demo application in LabVIEW using the ATIDAQFT Automation server and the Analog Input VIs provided by NI-DAQ. This sample application provides a real-time display of F/T data.

5.3 Designing Your DAQ F/T Application

Your DAQ F/T application must include at least two components:

5.3.1 Device Drivers for Your DAQ Device and Target Operating System

National Instruments includes several sets of Windows device drivers with their data acquisition devices, including 32-bit DLLs, LabVIEW VIs, and ActiveX controls. Non-Windows device drivers for National Instruments systems may be available from third-party sources. For other brands of data acquisition devices, device drivers must be obtained from the device manufacturer or a third-party source.

5.3.2 ATI DAQ F/T Components or C Library

This part of your application is used to load a calibration file, apply settings such as tool transformations, and convert raw voltages into forces and torques. For Windows applications, the ATI DAQ FT Automation server is recommended. The conversion to forces and torques can occur in real time, or can be applied as a batch operation at the end of the acquisition operation.

In some applications, using the ATI DAQ FT component to process data is impractical. This could be due to client applications or operating systems that do not support ActiveX, or very high-speed, real-time performance requirements. In these cases, ATI DAQ FT can be used during configuration stages, but need not be present in the final application. For more information, see the ATI DAQ FT Component Reference/Designing Your Application/ Advanced Techniques section of the ATI DAQ FT help file.



CAUTION: When any strain gage is saturated or otherwise inoperable, **all** transducer F/T readings are invalid.

6. Electrical Connection Information

This section contains detailed information about the electrical connections of the various F/T system components.

Aside:

Information in this section is intended for advanced users. Users whose systems include an ATI-supplied DAQ card may skip this section.

The ATI DAQ F/T software features a modular design to allow you to use our system with any data acquisition system capable of electrically interfacing to the transducer.

Once you have obtained the digitized transducer data per your data acquisition card instructions, the data needs to be transformed into force and torque data using the drivers and instructions on the ATI DAQ F/T software CD.

6.1 Signals and Power



CAUTION: The analog signals output by the transducer do not map directly into force and torque vectors. ATI DAQ F/T software must be used to convert these values into force and torque data.

Signal Name	Description
SGx Output	The non-inverting (positive) half of output of SGx
SGx Reference	The inverting (negative) half of output of SGx
+V _{ANA}	Positive power supply used by transducer
AGnd	Power supply return used by transducer
-V _{ANA}	Negative power supply used by transducer
+5V	Positive power used by PS or IFPS box
0V	Power supply return used by PS or IFPS box
AI Gnd	Analog Input Ground used for input current return from data acquisition card
Reserved	This connection has an internal or future use. Do not use.

Table 6.1—Signal Descriptions

Systems with an ATI-supplied DAQ card have their power derived from the DAQ card. If you are using your own DAQ card, you will need to provide a +5V power and 0V power to the PS or IFPS box. Without a PS box, you will need to supply +V_{ANA}, AGnd, and -V_{ANA} power to the transducer. (This applies to 9105-TIF transducers only; 9105-TW transducers require their IFPS box.)

6.2 Electrical Specifications

6.2.1 PS and IFPS box with transducer attached.

Signal	Minimum	Typical	Maximum	Units
+5V Power Input Voltage	4.65	5.00	9.00	V DC
+5V Power Input Current		600		mA
+5V Power Input Noise			75	mV p-p
+5V Power Input Regulation			0.5%	

Table 6.2—PS and IFPS box with transducer attached

6.2.2 Transducer with On-board Interface Board

Signal	Minimum	Typical	Maximum	Units
+V _{ANA} Power Input Voltage	13.00	15.00	17.00	V DC
-V _{ANA} Power Input Voltage	-17.00	-15.00	-13.00	V DC
+V _{ANA} Power Input Current			50	mA
-V _{ANA} Power Input Current			-45	mA
V _{ANA} Power Input Noise			75	mV p-p
V _{ANA} Power Input Regulation			0.5%	

Table 6.3—Transducer with On-board Interface Board

6.2.3 Transducer Output Signals

These are output by the transducer and passed through the PS box or are output by the IFPS box.

Signal	Minimum	Maximum	Units
SGx output*	-V _{ANA} +0.6	+V _{ANA} -0.8	V
SGx reference	AGnd	AGnd	V
SGx output, over 10V calibrated range	-10	+10	V
SGx output, over 5V calibrated range	-5	+5	V

* These output levels only occur if the transducer is loaded significantly past its calibration range.

Table 6.4—Transducer Output Signals

The transducer outputs are designed to work with a differential input to the DAQ system for best performance. Transducer outputs are ground-referenced differential signals

The calibrated output voltage range is indicated as a suffix to the calibration. For example, a Gamma transducer with SI-65-5 calibration and a +10V output voltage range would be expressed as a *GAMMA/SI-65-5:10V*. The output voltage range can also be read using the *OutputRange* property of the ATIDAQFT software component.

6.3 Transducer Signals

This section covers the connections for transducers with on-board electronics (9105-TIF part numbers). These transducers have a 20-pin connector. User connections to transducers without on-board electronics (9105-TWx part numbers) are not supported and therefore not covered in this document.

A 9105-TIF transducer connector mates to a Hirose HR25-9TP-20S connector. A 9105-TIF-x-IP_x Transducer connector mates to a Lemo FGG.3K.320 connector. Wire colors are shown for use with 9105-C-x-U cable assemblies.

Note: Multi-colored wires are identified as follows: The first color listed is the predominant color of the wire and the second color is the stripe on the wire.

H	L	Description	Wire Colors
1	7	SG0 output	Brown
2	5	Reserved	Orange
3	8	SG0 reference	Brown/White
4	14	SG3 reference	Blue/White
5	18	SG5 reference	Grey/White
6	1	+V _{ANA} power input	Red
7	9	SG1 output	Yellow
8	13	SG3 output	Blue
9	17	SG5 output	Grey
10	4	AGnd power input	Black
11	2	-V _{ANA} power input	Red/White
12	10	SG1 reference	Yellow/White
13	15	SG4 output	Violet
14	19	Ch7 output	White
15	3	Ch7 reference	Black/White
16	6	Reserved	Orange/White
17	11	SG2 output	Green
18	16	SG4 reference	Violet/White
19	20	Reserved	White/Black
20	12	SG2 reference	Green/White
Shell		Shielding	Shield

H = 9105-TIF Transducer

L = 9105-TIF-x-IP_x Transducer

Table 6.5—Transducer connector connections and 9105-C-x-U cable wire colors

6.4 PS and IFPS Signals

6.4.1 PS 20-pin Circular Connector

These signals and pin numbering are the same as the *H* transducer signals listed in *Section 6.3—Transducer Signals*. See Table 6.5.

6.4.2 PS and IFPS 26-pin High Density D-Subminiature Connector

This connector mates to an industry standard female 26-pin high-density D-subminiature connector with screw locks. Wire colors are shown for use with 9105-C-PS-U cable assemblies.

Pin	Description	Wire Colors
1	Reserved	Orange
2	+5V power input	Red
3	Ch7 output	White
4	SG5 output	Grey
5	SG4 output	Violet
6	SG3 output	Blue
7	SG2 output	Green
8	SG1 output	Yellow
9	SG0 output	Brown
10	Reserved	Orange/White
11	0V power input	Red/White
12	Ch7 reference	White/Black
13	SG5 reference	Grey/White
14	SG4 reference	Violet/White
15	SG3 reference	Blue/White
16	SG2 reference	Green/White
17	SG1 reference	Yellow/White
18	SG0 reference	Brown/White
19	Reserved	Black/White
22	AI Gnd	Black
Shell	Shielding	Shield

Table 6.6—PS box and IFPS box connector connections and 9105-C-PS-U cable wire colors

6.5 DAQ Card Connections

6.5.1 Standard DAQ Card Connections

The standard DAQ card configuration is based on the National Instruments connections. Advanced users can use the following table to better understand the system connections. Unlisted connector pins are not used.

H	L	PS	NI	ATI Signal	(NI name)
		2	8	+5V power	(+5V)
		11	13	0V power	(D Gnd)
6	1			+V _{ANA} power	
10	4	22	56	AGnd/AIGnd	(AIGnd)
11	2			-V _{ANA} power	
1	7	9	68	SG0 output	(AI 0)
3	8	18	34	SG0 reference	(AI 8)
7	9	8	33	SG1 output	(AI 1)
12	10	17	66	SG1 reference	(AI 9)
17	11	7	65	SG2 output	(AI 2)
20	12	16	31	SG2 reference	(AI 10)
8	13	6	30	SG3 output	(AI 3)
4	14	15	63	SG3 reference	(AI 11)
13	15	5	28	SG4 output	(AI 4)
18	16	14	61	SG4 reference	(AI 12)
9	17	4	60	SG5 output	(AI 5)
5	18	13	26	SG5 reference	(AI 13)
14	19	3	25	Ch7 output	(AI 6)
19	20	12	58	Ch7 reference	(AI 14)
2	5	1	57	reserved	(AI 7)
16	6	10	23	reserved	(AI 15)
15	3	11	52	for 9105-C-PS-V68 cables reserved	(P0.0)
			11	for 9105-C-PS-NI cables reserved	(PFI0)
Shell	Shell	Shell	Shell	Shielding	

- H = 9105-TIF-x Transducer connector
- L = 9105-TIF-x-IPx Transducer connector
- PS = DAQ-side connector on PS or IFPS box
- NI = DAQ connector on National Instruments board

Table 6.7—System Connections

6.5.2 Custom DAQ Card Connects

Advanced users may have purchased systems that use an unterminated power supply cable. The NI signal names listed in Table 6.7 may be used as a guide when connecting the unterminated cable to other National Instruments data acquisition equipment.

Figures 6.1 and 6.2 show example connection schemes for connecting an IFPS or PS box to a data

acquisition system. In this case, the signal names on the examples must be matched to equivalent names on the data acquisition system. The optional Ch7 connections are not shown here, but they can be found in Table 6.7—System Connections. Differential signal connections are preferred as they will give the best results (see Figure 6.1).

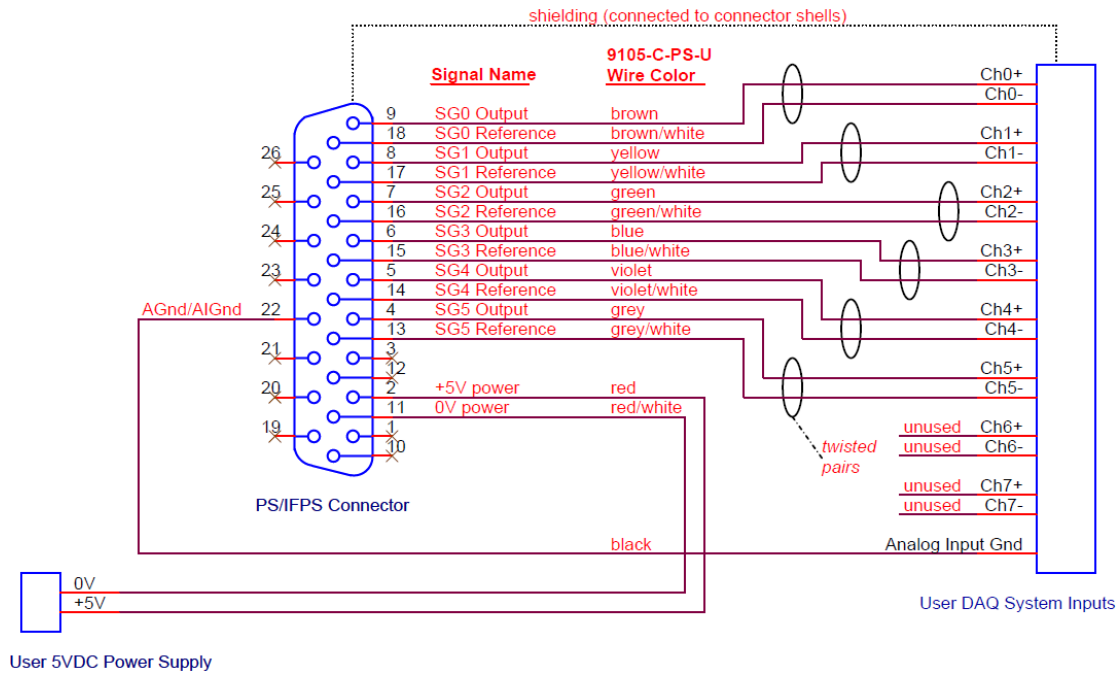

Figure 6.1—Differential Connections to a Data Acquisition System

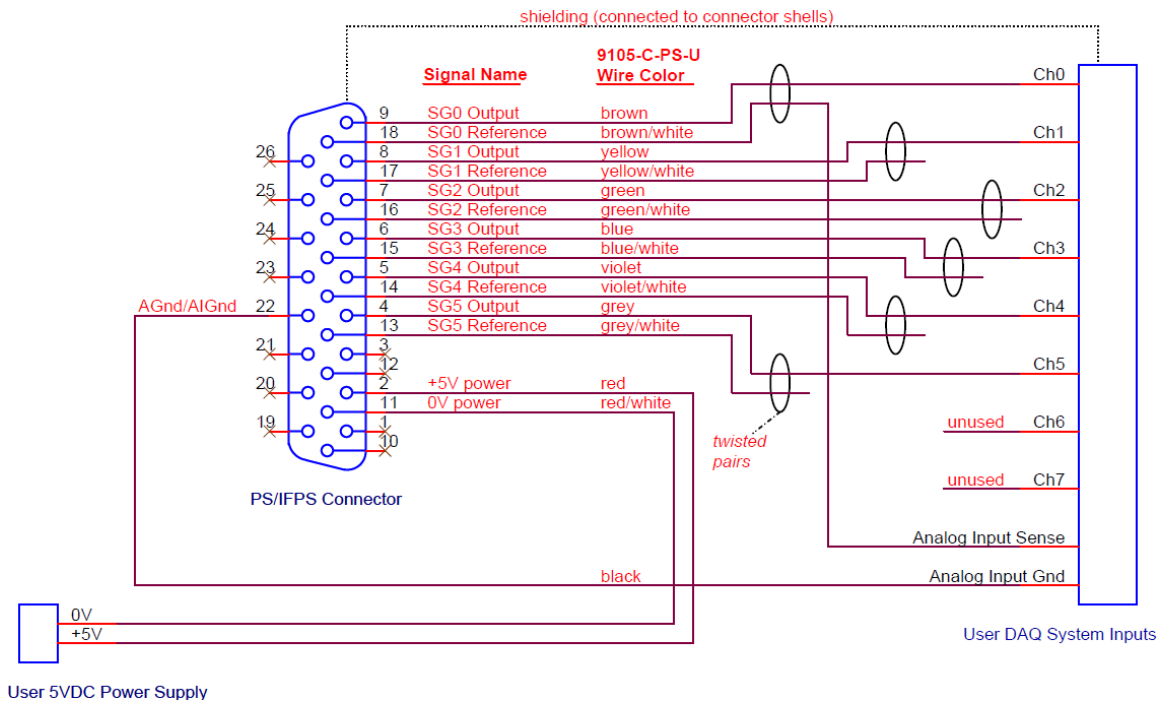

Figure 6.2—Single-Ended Connections to a Data Acquisition System

A connection from the DAQ F/T's *AGnd/AIGnd* line to the data acquisition system's analog input ground or analog ground is required in most cases. This line allows the return of the tiny amount of current used by the data acquisition system. Noise can result if this current isn't returned via the *AGnd/AIGnd* path.

For best noise performance, the cabling from the PS/IFPS connector should be shielded and each strain gage's signals in a twisted pair. The shielding should be connected to the PS/IFPS connector shell and to the shell of the data acquisition system's connector. If there is no connector at the data acquisition system or if its connector shell is electrically floating, then the shield at the PS/IFPS connector should also be connected to the *AGnd/AIGnd* signal.

It may be important to consider the voltage drop *+5V power* and *0V power* lines to be certain that a sufficient voltage is delivered to the PS/IFPS box. Please note that as the delivered voltage drops, the current consumption will increase.

6.6 Using Unused DAQ Card Resources

There are additional functions available on the ATI-supplied DAQ card that are not used in the standard configuration. Information about using these resources is outside the scope of this manual. Users who wish to use these need to consult the DAQ card documentation for connections and functionality. Table 6.7 shows which signals are used by the F/T system and cannot be used for other purposes. Additional connections to the DAQ card can introduce ground loops and noise if not designed properly.

7. Advanced Topics

7.1 Writing DAQ F/T Application

See the ATI DAQ FT help file for information on developing your own application.

7.2 Data Collection Rates

Our DAQ F/T sensor systems are designed to be electrically compatible with most commercially-available, general-purpose and high-accuracy data acquisition hardware. For best performance in all applications, the transducer electronics do not filter the outputs. This allows collection of all transducer frequency content. Please note that to satisfy the Nyquist Theorem[†], the data needs to be coupled at a rate that is greater than twice the highest frequency present, even if you are not interested in data at that frequency.

Please note that significant error can be introduced in the transducer data if a National Instruments E-Series card is sampling each data set at over 40 kHz (240 kHz per channel). Users with fast NI-DAQ devices should not use the single-scan functions of NI-DAQ, such as AI_Read_Scan and AI-VRead_Scan. A buffered operation (such as Scan_Op) should be used instead. In the demo, *ATI DAQ FT Demo*, the *Buffer Mode* option should be enabled.

[†]The Nyquist Theorem applies to data collection and states that data acquired must be collected at a data rate greater than twice the highest frequency present in the data, otherwise the data will be erroneous. The theorem was developed by Henry Nyquist as he sought to improve communications systems in the first part of the twentieth century.

7.3 Multiple Calibrations

Some transducers have multiple calibrations, usually to allow the transducer to have larger range in one instance and finer resolution in another. Changing to another calibration is done by loading the new calibration. This is done in the demo software through the File/Open Calibration memo or in your application by updating the CalFilePath property.

7.4 Detecting Failures (Diagnostics)

7.4.1 Detecting Connection Issues

The F/T system is designed to output voltages that are within the specified output voltage range ($\pm 5V$ or $\pm 10V$) as long as the transducer is not being overloaded and the transducer is connected to the PS or IFPS box. If the transducer cable is disconnected or has been damaged, the output of the system will be outside the specified output voltage range. By performing periodic checks of the voltages, a failure can be detected. If any of the voltages are at or outside this range, there may be a problem with the transducer or its cabling.



CAUTION: When any strain gage output is saturated or otherwise inoperable, all transducer F/T readings are invalid. Therefore, it is vitally important to monitor for these conditions.

7.4.2 Detecting Cable Problems

A properly functioning DAQ system will deliver voltages from the transducer to the DAQ card inputs that represent the transducer loading. The DAQ system provides two safety features to aid in detection of cabling problems that could disrupt the reading of transducer voltages.

1. If the cable is disconnected between the transducer and its IFPS or PS box, then voltages sent to the DAQ card from the box will be forced to a saturation level.

2. The seventh output channel outputs a voltage that is either -1.54V if no temperature reader circuit is installed or a voltage that is greater than +0.5V if the temperature reader is installed and the temperature is above -10°C.

If the acquired transducer voltages are A/D saturated or the seventh channel is not between -1.6V to -1.5V or not between +0.5V and saturation, then there may be a cable issue.

7.4.3 Detecting Sensitivity Changes

Sensitivity checking of the transducer can also be used to measure the transducer system's health. This can be done by applying known loads to the transducer and verifying the system output matches the known loads.

For example, a transducer mounted to a robot arm may have an end-effector attached to it:

1. If the end-effector has moving parts, they must be moved in a known position.
2. Place the robot arm in an orientation that allows the gravity load from the end-effector to exert load on many transducer output axes.
3. Record the output readings.
4. Position the robot arm to apply another load, this time causing the outputs to move far from the earlier readings.
5. Record the second set of output readings.
6. Find the differences from the first and second set of readings and use it as your sensitivity value.

Even if the values vary somewhat from sample set to sample set, they can be used to detect gross errors. Either the resolved outputs or the raw transducer voltages may be used (the same must be used for all steps of this process).

7.5 Scheduled Maintenance

7.5.1 Periodic Inspection

For most applications there are no parts that need to be replaced during normal operation. With industrial-type applications that continuously or frequently move the system's cabling, you should periodically check the cable jacket for signs of wear. These applications should implement the procedures discussed in *Section 7.4—Detecting Failures (Diagnostics)* to detect any failures.

The transducer must be kept free of excessive dust, debris, or moisture. Applications with metallic debris (i.e., electrically-conductive) must protect the transducer from this debris. Transducers without specific factory-installed protection are to be considered unprotected. The internal structure of the transducers can become clogged with particles and will become uncalibrated or even damaged.

7.5.2 Periodic Calibration

Periodic calibration of the transducer and DAQ card is required to maintain traceability to national standards. Follow any applicable ISO-9000-type standards for calibration. ATI Industrial Automation recommends annual recalibrations, especially for applications that frequently cycle the loads applied to the transducer.

7.6 A Word about Resolution

ATI's transducers have a three sensing beam configuration where the three beams are equally spaced around a central hub and attached to the outside wall of the transducer. This design transfers applied loads to multiple sensing beams and allows the transducer to increase its sensing range in a given axis if a counterpart axis has reduced loading (see *9620-05-Transducer Section—Installation, Operation, and Specification Manual* for compound loading information).

The resolution of each transducer axis depends on how the applied load is spread among the sensing beams. The best resolution occurs in the scenario when the quantization of the gages is evenly distributed as load is applied. In the worst case scenario, the discrete value of all involved gages increases at the same time. The typical scenario will be somewhere in between these two.

F/T resolutions are specified as *typical resolution*, defined as the average of the worst and best case scenarios. Because both multi-gage effects can be modeled as a normal distribution, this value represents the most commonly perceived, average resolution. The DAQ F/T resolutions are based on real-number calculations and do not result in clean fractions. To express the values as clean fractions, we simply use the values that a 16-bit DAQ card could achieve. Although this misrepresents the actual performance of the transducers, it results in a close (and always conservative) estimate.

7.7 Environmental

The standard F/T system is designed to be used in standard laboratory or light-manufacturing conditions. Transducers with an IP60 designation are able to withstand dusty environments, those with an IP65 designation are able to withstand dusty environments and wash down, and those with an IP68 designation are able to withstand dusty environments and freshwater immersion to a specified depth. See ATI Industrial Automation manual (9620-05-Transducer Section—*Installation, Operation and Specification Manual*) for transducer environmental information.

IP60 and non-IP rated transducers, the PS box, and the IFPS box can be used in environments with up to 95% relative humidity, non-condensing.

	Storage	Operation	Units
PS box	-30 to 75	0 to 60	°C
IFPS box	-30 to 75	0 to 60	°C

Note: These temperature ranges specify the storage and operation ranges in which the electronics can survive without damage. They do not take accuracy into account.

Table 7.1—Transducer Temperature Ranges

8. Troubleshooting

8.1 Introduction

This section includes answers to some issues that might arise when setting up and using the F/T system. The question or problem is listed followed by the probable answer or solution and are categorized for easy reference.

The information in this section should answer many questions that might arise in the field. Customer service is available to users who have problems or questions not addressed in the manuals:

**ATI Industrial Automation
Customer Service**

Pinnacle Park
1031 Goodworth Drive
Apex, NC 27539 USA

Phone: +1.919.772.0115
Fax: +1.919.772.8259
E-mail: ft_support@ati-ia.com

Note:

Please read the F/T manuals before calling customer service. When calling, have the following information available:

1. Serial number(s)
2. Transducer type, e.g., Nano-17, Gamma, Theta
3. Calibration, e.g., US-15-50, SI-130-10
4. An accurate and complete description of the question or problem.
5. Controller revision. This is output in the initialization header message of the Controller.

If possible, the F/T system should be accessible when talking with an ATI Industrial Automation customer service representative.

8.2 Questions and Answers

8.2.1 Errors with force and torque readings

Bad data from the transducer's strain gages can cause errors in force/torque readings. These errors can result in problems with threshold monitoring, sensor biasing and accuracy. Listed below are the basic conditions of bad data. Use this to troubleshoot your problem. In most cases, problems can be seen better while viewing raw strain gage data.

Question/Problem:	Answer/Solution:
Saturation	When the data from a raw decimal strain gage reads the positive or negative maximums, that gage is saturated. Saturation occurs if the sensor is loaded beyond its rated maximum or in the event of an electrical failure within the system.
Noise	Excessive noise can be caused by mechanical vibrations and electrical disturbances, possibly from a poor ground. It can also indicate component failure within the system.
Drift	After a load is removed or applied, the raw gage reading does not stabilize but continues to increase or decrease. This may be observed more easily while viewing resolved F/T data. Drift is caused by temperature change, mechanical coupling, or internal failure. Mechanical coupling is caused when a physical connection is made between the tool plate and the sensor body (i.e., plastic filings between the tool adapter plate and the transducer body). Some mechanical coupling is common, such as hoses and wires attached to a tool.
Hysteresis	When the sensor is loaded and then unloaded, gage readings do not return quickly and completely to their original readings. Hysteresis is caused by mechanical coupling (explained in drift section) or internal failure.

9. Appendix A—Multiple IFPS Boxes

9.1 9105-IFPSMC Boxes

Multiple-IFPS boxes are special order items that replace the standard IFPS box and allow multiple transducers to be easily connected to a single data acquisition card or to a pair of data acquisition cards (required in some cases for larger numbers of transducers).



Figure 9.1—A Typical Multiple 9105-IFPSMC Box

The Multiple-IFPS box is designed so that it connects to the supplied data acquisition card using standard cabling. All data acquisition cabling and the power connection are on the back of the box. The Multiple-IFPS box includes an external wall-mounted power supply. Connections to the 9105-TW-type transducers are at the front of the box. The box features slotted mounting feet so that it can be easily mounted to a surface.

Aside:

Like the standard DAQ F/T systems, the transducer signals from the multiple-IFPS box are configured for differential input channels.

Aside:

The ATI demo software and National Instruments driver require a scan list that indicates which channels are used for a transducer. For example, a 9105-IFPSMC-3 connected to the DAQ card `dev1` would require the scan list `dev1/ai18:23` to read transducer 2. The same system would use the scan list `dev1/38:39,dev1/ai48:51` to read transducer 4.

9.1.1 Transducer Connections

The IFPSMC transducer connectors are numbered 1 through 6 starting at the bottom of the box at 1 and working upwards to 6.

The following tables show the channel assignments for the 9105-IFPSMC and National Instruments card using National Instruments' nomenclature. Please note that transducers are generally assigned to the IFPSMC so that unused channels are grouped together. Channels that do not have a transducer assigned to them by ATI Industrial Automation may be used for other purposes through the *External User Equipment* connectors.

Aside:

Signals to and from the data acquisition card that are not being used for transducer connections are passed to the user via the *External User Equipment* connectors.

Transducer	Signal	NI Differential Channel	NI +Input Channel	NI -Input Channel	NI +Input Pin	NI -Input Pin
1	SG0	ai4	ai4	ai12	0.28	0.61
	SG1	ai5	ai5	ai13	0.60	0.26
	SG2	ai6	ai6	ai14	0.25	0.58
	SG3	ai7	ai7	ai15	0.57	0.23
	SG4	ai16	ai16	ai24	1.68	1.34
	SG5	ai17	ai17	ai25	1.33	1.67

Table 9.1—Signal Allocation for Transducer 1

Transducer	Signal	NI Differential Channel	NI +Input Channel	NI -Input Channel	NI +Input Pin	NI -Input Pin
2	SG0	ai18	ai18	ai26	1.32	1.66
	SG1	ai19	ai19	ai27	1.65	1.31
	SG2	ai20	ai20	ai28	1.30	1.64
	SG3	ai21	ai21	ai29	1.29	1.63
	SG4	ai22	ai22	ai30	1.62	1.28
	SG5	ai23	ai23	ai31	1.27	1.61

Table 9.2—Signal Allocation for Transducer 2

Transducer	Signal	NI Differential Channel	NI +Input Channel	NI -Input Channel	NI +Input Pin	NI -Input Pin
3	SG0	ai32	ai32	ai40	1.26	1.60
	SG1	ai33	ai33	ai41	1.59	1.25
	SG2	ai34	ai34	ai42	1.24	1.58
	SG3	ai35	ai35	ai43	1.23	1.57
	SG4	ai36	ai36	ai44	1.55	1.21
	SG5	ai37	ai37	ai45	1.20	1.54

Table 9.3—Signal Allocation for Transducer 3

Transducer	Signal	NI Differential Channel	NI +Input Channel	NI -Input Channel	NI +Input Pin	NI -Input Pin
4	SG0	ai38	ai38	ai46	1.19	1.53
	SG1	ai39	ai39	ai47	1.52	1.18
	SG2	ai48	ai48	ai56	1.17	1.51
	SG3	ai49	ai49	ai57	1.16	1.50
	SG4	ai50	ai50	ai58	1.49	1.15
	SG5	ai51	ai51	ai59	1.14	1.48

Table 9.4—Signal Allocation for Transducer 4

Transducer	Signal	NI Differential Channel	NI +Input Channel	NI -Input Channel	NI +Input Pin	NI -Input Pin
5	SG0	ai52	ai52	ai60	1.13	1.47
	SG1	ai53	ai53	ai61	1.46	1.12
	SG2	ai54	ai54	ai62	1.11	1.45
	SG3	ai55	ai55	ai63	1.10	1.44
	SG4	ai64	ai64	ai72	1.42	1.8
	SG5	ai65	ai65	ai73	1.7	1.41

Table 9.5—Signal Allocation for Transducer 5

Transducer	Signal	NI Differential Channel	NI +Input Channel	NI -Input Channel	NI +Input Pin	NI -Input Pin
6	SG0	ai66	ai66	ai74	1.6	1.40
	SG1	ai67	ai67	ai75	1.39	1.5
	SG2	ai68	ai68	ai76	1.4	1.38
	SG3	ai69	ai69	ai77	1.3	1.37
	SG4	ai70	ai70	ai78	1.36	1.2
	SG5	ai71	ai71	ai79	1.1	1.35

Table 9.6—Signal Allocation for Transducer 6

Signal	NI Differential Channel	NI +Input Channel	NI -Input Channel	NI +Input Pin	NI -Input Pin
user	ai0	ai0	ai8	0.68	0.34
user	ai1	ai1	ai9	0.33	0.66
user	ai2	ai2	ai10	0.65	0.31
user	ai3	ai3	ai11	0.30	0.63

Table 9.7—Signal Allocation for User Channels

Note: All channels and signals reflect National Instruments’ nomenclature. Check NI’s documentation for information about using differential channels.

Transducer	National Instruments Scan List
1	devx/ai4:7, devx/ai16:17
2	devx/ai18:23
3	devx/ai32:37
4	devx/ai38:39, devx/ai48:51
5	devx/ai52:55, devx/ai64:65
6	devx/ai66:71

Table 9.8—9105-IFPS Scan List for Each Transducer

9.1.2 Power

The small connector on the rear of the box is for power input. A Murr 7000-08481-0000000 connector (female) may be used to mate with the power input connector.

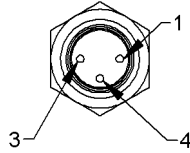

Figure 9.2—Power Input Connector

Pin	Description
1	+V input
3	0V input
4	No connection

Table 9.9—IFPSMC Power Input Connector Pin Assignments

The IFPSMC accepts from +4VDC to +15VDC.

Model	Current Draw		
	@ 5VDC	@12VDC	@15VDC
9105-IFPSMC-2	0.36A	0.19A	0.16A
9105-IFPSMC-3	0.54A	0.28A	0.24A
9105-IFPSMC-4	0.72A	0.37A	0.32A
9105-IFPSMC-5	0.90A	0.46A	0.40A
9105-IFPSMC-6	1.08A	0.56A	0.48A

Table 9.10—Typical Input Current at Various Voltages at Room Temperature

9.1.3 Recalibration

The electronics in the IFPSMC are needed along with the transducers when the transducers are being recalibrated. It is preferable to send the entire IFPSMC box along with the transducers to be recalibrated. Occasionally, circumstances require the recalibration of a single transducer, while the other transducers remain in use. In this case, it is necessary to remove the transducer’s IFPS board from the IFPSMC box so it may accompany the transducer to recalibration. This should only be done under the guidance of ATI customer service personnel.

9.1.3.1 Removing the IFPS Card



CAUTION: The following steps need to be done at an anti-static workstation.

1. Disconnect all cables from the IFPS box.
2. Remove the four screws from the corners of the box’s front panel.
3. Carefully swing the front panel to the right side of the box, as shown in *Figure 9.3—IFPSMC with Open Front Panel*.

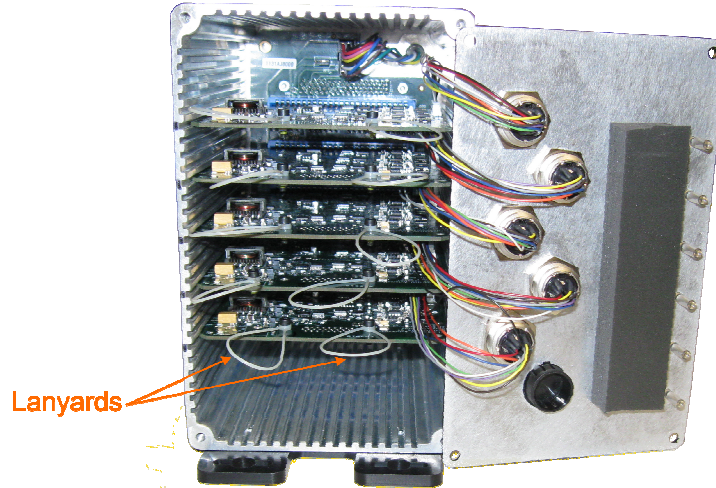

Figure 9.3—IFPSMC with Opened Front Panel

4. Identify the IFPS to be removed by following the wires from the associated transducer connector.
5. While firmly holding the top of the IFPSMC box, simultaneously pull the two lanyards for the identified IFPS. The IFPS card should slide out.
6. Gently and carefully remove the transducer connector harness from the IFPS card by simultaneously prying up both ends of the harness's board end connector using your fingernails. See the "Lift Here" call out in *Figure 9.4—Transducer Connector Harness Connection*.

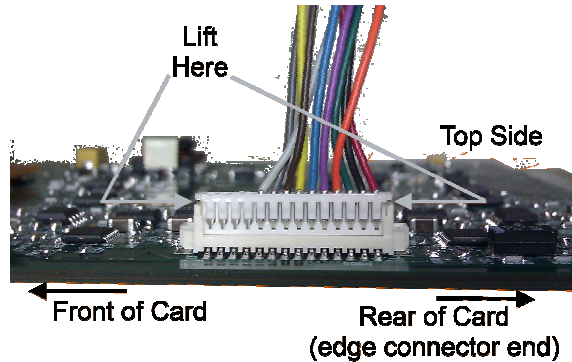

Figure 9.4—Transducer Connector Harness Connection

7. Note the serial number on the IFPS card, which slot it came from and which transducer it was connected to. *Table 9.11—IFPSMC IFPS Cards and Transducers* is provided for you to record this information.

Slot	IFPS Card SN	Transducer SN	Notes
Transducer 6			
Transducer 5			
Transducer 4			
Transducer 3			
Transducer 2			
Transducer 1			

Table 9.11—IFPSMC IFPS Cards and Transducers

8. Place card in an anti-static bag.

9.1.3.2 Reinstalling an IFPS Card

9. To reinstall an IFPS card, just do the reverse of removal instructions.

9.2 Legacy 9105-IFPSM and 9105-IFPS Boxes

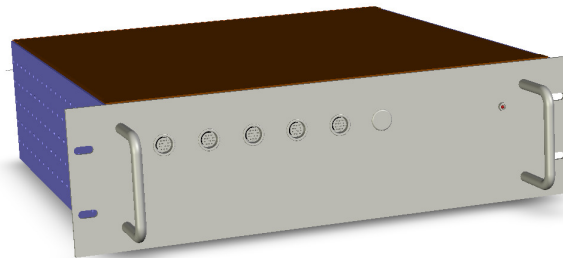

Figure 9.5—A Typical Legacy Multiple-IFPS Box

For M-Series DAQ Card:		For E-Series DAQ Card:	
Without User Channels	With User Channels	Without User Channels	With User Channels
–	–	9105-IFPS-2	9105-IFPS-2-E
9105-IFPSM-3	9105-IFPSM-3E	9105-IFPS-3	9105-IFPS-3-E
9105-IFPSM-4	9105-IFPSM-4E	9105-IFPS-4	–
9105-IFPSM-5	9105-IFPSM-5E	9105-IFPS-5	9105-IFPS-5-E
9105-IFPSM-6	9105-IFPSM-6E	9105-IFPS-6	9105-IFPS-6-E
–	–	9105-IFPS-7	9105-IFPS-7-E
–	–	9105-IFPS-8	–

Table 9.12—Legacy Multiple IFPS Box Configurations

Legacy Multiple-IFPS boxes contain their own power supply and require standard wall power to operate. Boxes with the *E* option contain a 50-pin male DB50 connector, known as the *User Channels* connector, to allow access to data acquisition card channels unused by the transducers. The Legacy Multiple-IFPS box connects to the supplied data acquisition card or cards with standard cabling.

The box can be installed in a 19" rack mount or used as a table-top unit. All data acquisition cabling and power connections are at the back of the box. Connections to the 9105-TW-type transducers are at the front of the box.

Aside:

Like the standard DAQ F/T systems, the transducer signals from a legacy multiple IFPS box are configured for differential input channels.

Aside:

The ATI demo software and National Instruments driver require a scan list that indicates which channels are used for a transducer. For example, a 9105-IFPSM-3 connected to the DAQ card *dev1* would require the scan list *dev1/ai0:ai5* to read transducer 1. The same system would use the scan list *dev1/ai6:ai7,dev1/ai16:ai19* to read transducer 2.

9.2.1 9105-IFPSM-3 and 9105-IFPSM-3E Signal Allocation

Transducer	Signal	NI Differential Channel
1	G0	ai0
	G1	ai1
	G2	ai2
	G3	ai3
	G4	ai4
	G5	ai5
2	G0	ai6
	G1	ai7
	G2	ai16
	G3	ai17
	G4	ai18
	G5	ai19
3	G0	ai20
	G1	ai21
	G2	ai22
	G3	ai23
	G4	ai32
	G5	ai33

Table 9.13—Transducer Channel Assignment for 9105-IFPSM-3 and 9105-IFPSM-3E

BNC Connector	NI Signal
Center	ExtStrobe
Outside	DGnd

Table 9.14—BNC Connector Signals

DB50 pin	NI Signal
1	ai42
2	ai34
3	ai43
4	ai35
5	ai44
6	ai36
7	ai45
8	ai37
9	ai46
10	ai38
11	ai47
12	ai39
13	ai56
14	ai48
15	ai57
16	ai49
18	ai58
19	ai50
20	ai59
21	ai51
22	ai60
23	ai52
24	ai61
25	ai53
26	ai62
27	ai54
28	ai63
29	ai55
30	ai72
31	ai64
32	ai73
33	ai65
34	ai74
35	ai66
36	ai75
37	ai67
38	ai76
39	ai68
40	ai77
41	ai69
42	ai78
43	ai70
44	ai79
45	ai71
17	AIgnd
50	AI Sense2

Table 9.15—User Channel Connector for 9105-IFPSM-3E. DB50 pins not listed are unused

Note: All channels and signals reflect National Instruments' nomenclature. Check NI's documentation for information about using differential channels.

9.2.2 9105-IFPSM-4 and 9105-IFPSM-4E Signal Allocation

Transducer	Signal	NI Differential Channel
1	G0	ai0
	G1	ai1
	G2	ai2
	G3	ai3
	G4	ai4
	G5	ai5
2	G0	ai6
	G1	ai7
	G2	ai16
	G3	ai17
	G4	ai18
	G5	ai19
3	G0	ai20
	G1	ai21
	G2	ai22
	G3	ai23
	G4	ai32
	G5	ai33
4	G0	ai34
	G1	ai35
	G2	ai36
	G3	ai37
	G4	ai38
	G5	ai39

Table 9.16—Transducer Channel Assignment for 9105-IFPSM-4 and 9105-IFPSM-4E

BNC Connector	NI Signal
Center	ExtStrobe
Outside	DGnd

Table 9.17—BNC Connector Signals

DB50 Pin	NI Signal
1	ai56
2	ai48
3	ai57
4	ai49
5	ai58
6	ai50
7	ai59
8	ai51
9	ai60
10	ai52
11	ai61
12	ai53
13	ai62
14	ai54
15	ai63
16	ai55
18	ai72
19	ai64
20	ai73
21	ai65
22	ai74
23	ai66
24	ai75
25	ai67
26	ai76
27	ai68
28	ai77
29	ai69
30	ai78
31	ai70
32	ai79
33	ai71
17	AIgnd
50	AI Sense2

Table 9.18—User Channel Connector for 9105-IFPSM-4E. DB50 pins not listed are unused

Note: All channels and signals reflect National Instruments' nomenclature. Check NI's documentation for information about using differential channels.

9.2.3 9105-IFPSM-5 and 9105-IFPSM-5E Signal Allocation

Transducer	Signal	NI Differential Channel
1	G0	ai0
	G1	ai1
	G2	ai2
	G3	ai3
	G4	ai4
	G5	ai5
2	G0	ai6
	G1	ai7
	G2	ai16
	G3	ai17
	G4	ai18
	G5	ai19
3	G0	ai20
	G1	ai21
	G2	ai22
	G3	ai23
	G4	ai32
	G5	ai33
4	G0	ai34
	G1	ai35
	G2	ai36
	G3	ai37
	G4	ai38
	G5	ai39
5	G0	ai48
	G1	ai49
	G2	ai50
	G3	ai51
	G4	ai52
	G5	ai53

Table 9.19—Transducer Channel Assignment for 9105-IFPSM-5 and 9105-IFPSM-5E

BNC Connector	NI Signal
Center	ExtStrobe
Outside	DGnd

Table 9.20—BNC Connector Signals

DB50 Pin	NI Signal
1	ai62
2	ai54
3	ai63
4	ai55
5	ai72
6	ai64
7	ai73
8	ai65
9	ai74
10	ai66
11	ai75
12	ai67
13	ai76
14	ai68
15	ai77
16	ai69
18	ai78
19	ai70
20	ai79
21	ai71
17	AI Gnd
50	AI Sense2

Table 9.21—User Channel Connector for 9105-IFPSM-5E. DB50 pins not listed are unused

Note: All channels and signals reflect National Instruments' nomenclature. Check NI's documentation for information about using differential channels.

9.2.4 9105-IFPSM-6 and 9105-IFPSM-6E Signal Allocation

Transducer	Signal	NI Differential Channel
1	G0	ai0
	G1	ai1
	G2	ai2
	G3	ai3
	G4	ai4
	G5	ai5
2	G0	ai6
	G1	ai7
	G2	ai16
	G3	ai17
	G4	ai18
	G5	ai19
3	G0	ai20
	G1	ai21
	G2	ai22
	G3	ai23
	G4	ai32
	G5	ai33
4	G0	ai34
	G1	ai35
	G2	ai36
	G3	ai37
	G4	ai38
	G5	ai39
5	G0	ai48
	G1	ai49
	G2	ai50
	G3	ai51
	G4	ai52
	G5	ai53
6	G0	ai54
	G1	ai55
	G2	ai64
	G3	ai65
	G4	ai66
	G5	ai67

Table 9.22—Transducer Channel Assignment for 9105-IFPSM-6 and 9105-IFPSM-6E

BNC Connector	NI Signal
Center	ExtStrobe
Outside	DGnd

Table 9.23—BNC Connector Signals

DB50 Pin	NI Signal
1	ai76
2	ai68
3	ai77
4	ai69
5	ai78
6	ai70
7	ai79
8	ai71
17	AI Gnd
50	AI Sense2

Table 9.24—User Channel Connector for 9105-IFPSM-6E. DB50 pins not listed are unused

Note: All channels and signals reflect National Instruments' nomenclature. Check NI's documentation for information about using differential channels.

9.2.5 9105-IFPS-2 and 9105-IFPS-2-E Signal Allocation

Transducer	Signal	NI Differential Channel
1	G0	ai0
	G1	ai1
	G2	ai2
	G3	ai3
	G4	ai4
	G5	ai5
	T	ai6
2	G0	ai16
	G1	ai17
	G2	ai18
	G3	ai19
	G4	ai20
	G5	ai21
	T	ai22

Table 9.25—Transducer Channel Assignment for 9105-IFPS-2 and 9105-IFPS-2-E

BNC Connector	NI Signal
Center	ExtStrobe
Outside	DGnd

Table 9.26—BNC Connector Signals

DB50 pin	NI Signal
18	ai32
19	ai40
20	ai33
21	ai41
22	ai34
23	ai42
24	ai35
25	ai43
26	ai36
27	ai44
28	ai37
29	ai45
30	ai38
31	ai46
32	ai39
33	ai47
34	ai48
35	ai56
36	ai49
37	ai57
38	ai50
39	ai58
40	ai51
41	ai59
42	ai52
43	ai60
44	ai53
45	ai61
46	ai54
47	ai62
48	ai55
49	ai63
17	AIgnd
50	AI Sense2

Table 9.27—User Channel Connector for 9105-IFPS-2-E. DB50 pins not listed are unused

Note: All channels and signals reflect National Instruments' nomenclature. Check NI's documentation for information about using differential channels.

9.2.6 9105-IFPS-3 and 9105-IFPS-3-E Signal Allocation

Transducer	Signal	NI Differential Channel
1	G0	ai0
	G1	ai1
	G2	ai2
	G3	ai3
	G4	ai4
	G5	ai5
	T	ai6
2	G0	ai16
	G1	ai17
	G2	ai18
	G3	ai19
	G4	ai20
	G5	ai21
	T	ai22
3	G0	ai32
	G1	ai33
	G2	ai34
	G3	ai35
	G4	ai36
	G5	ai37
	T	ai38

Table 9.28—Transducer Channel Assignment for 9105-IFPS-3 and 9105-IFPS-3-E

BNC Connector	NI Signal
Center	ExtStrobe
Outside	DGnd

Table 9.29—BNC Connector Signals9

Note: All channels and signals reflect National Instruments' nomenclature. Check NI's documentation for information about using differential channels.

DB50 pin	NI Signal
34	ai48
35	ai56
36	ai49
37	ai57
38	ai50
39	ai58
40	ai51
41	ai59
42	ai52
43	ai60
44	ai53
45	ai61
46	ai54
47	ai62
48	ai55
49	ai63
17	AI Gnd
50	AI Sense2

Table 9.30—User Channel Connector for 9105-IFPS-3-E. DB50 pins not listed are unused

9.2.7 9105-IFPS-4 Signal Allocation

Transducer	Signal	NI Differential Channel
1	G0	ai0
	G1	ai1
	G2	ai2
	G3	ai3
	G4	ai4
	G5	ai5
	T	ai6
2	G0	ai16
	G1	ai17
	G2	ai18
	G3	ai19
	G4	ai20
	G5	ai21
	T	ai22
3	G0	ai32
	G1	ai33
	G2	ai34
	G3	ai35
	G4	ai36
	G5	ai37
	T	ai38
4	G0	ai48
	G1	ai49
	G2	ai50
	G3	ai51
	G4	ai52
	G5	ai53
	T	ai54

Table 9.31—Transducer Channel Assignment for 9105-IFPSM-4

BNC Connector	NI Signal
Center	ExtStrobe
Outside	DGnd

Table 9.32—BNC Connector Signals

Note: All channels and signals reflect National Instruments' nomenclature. Check NI's documentation for information about using differential channels.

9.2.8 9105-IFPS-5 and 9105-IFPS-5-E Signal Allocation

Transducer	Signal	NI Differential Channel
1	G0	card 1:ai0
	G1	card 1:ai1
	G2	card 1:ai2
	G3	card 1:ai3
	G4	card 1:ai4
	G5	card 1:ai5
	T	card 1:ai6
2	G0	card 1:ai16
	G1	card 1:ai17
	G2	card 1:ai18
	G3	card 1:ai19
	G4	card 1:ai20
	G5	card 1:ai21
	T	card 1:ai22
3	G0	card 1:ai32
	G1	card 1:ai33
	G2	card 1:ai34
	G3	card 1:ai35
	G4	card 1:ai36
	G5	card 1:ai37
	T	card 1:ai38
4	G0	card 1:ai48
	G1	card 1:ai49
	G2	card 1:ai50
	G3	card 1:ai51
	G4	card 1:ai52
	G5	card 1:ai53
	T	card 1:ai54
5	G0	card 2:ai0
	G1	card 2:ai1
	G2	card 2:ai2
	G3	card 2:ai3
	G4	card 2:ai4
	G5	card 2:ai5
	T	card 2:ai6

Table 9.33—Transducer Channel Assignment for 9105-IFPS-5 and 9105-IFPS-5-E

BNC Connector	NI Signal
Center	ExtStrobe
Outside	DGnd

Table 9.34—BNC Connector Signals

DB50 Pin	NI Signal
1	card 2:ai16
2	card 2:ai24
3	card 2:ai17
4	card 2:ai25
5	card 2:ai18
6	card 2:ai26
7	card 2:ai19
8	card 2:ai27
9	card 2:ai20
10	card 2:ai28
11	card 2:ai21
12	card 2:ai29
13	card 2:ai22
14	card 2:ai30
15	card 2:ai23
16	card 2:ai31
18	card 2:ai32
19	card 2:ai40
20	card 2:ai33
21	card 2:ai41
22	card 2:ai34
23	card 2:ai42
24	card 2:ai35
25	card 2:ai43
26	card 2:ai36
27	card 2:ai44
28	card 2:ai37
29	card 2:ai45
30	card 2:ai38
31	card 2:ai46
32	card 2:ai39
33	card 2:ai47
34	card 2:ai48
35	card 2:ai56
36	card 2:ai49
37	card 2:ai57
38	card 2:ai50
39	card 2:ai58
40	card 2:ai51
41	card 2:ai59
42	card 2:ai52
43	card 2:ai60
44	card 2:ai53
45	card 2:ai61
46	card 2:ai54
47	card 2:ai62
48	card 2:ai55
49	card 2:ai63
17	AIgnd
50	AI Sense2

Table 9.35—User Channel Connector for 9105-IFPS-5-E. DB50 pins not listed are unused

Note: All channels and signals reflect National Instruments' nomenclature. Check NI's documentation for information about using differential channels.

9.2.9 9105-IFPS-6 and 9105-IFPS-6-E Signal Allocation

Transducer	Signal	NI Differential Channel
1	G0	card 1:ai0
	G1	card 1:ai1
	G2	card 1:ai2
	G3	card 1:ai3
	G4	card 1:ai4
	G5	card 1:ai5
	T	card 1:ai6
2	G0	card 1:ai16
	G1	card 1:ai17
	G2	card 1:ai18
	G3	card 1:ai19
	G4	card 1:ai20
	G5	card 1:ai21
	T	card 1:ai22
3	G0	card 1:ai32
	G1	card 1:ai33
	G2	card 1:ai34
	G3	card 1:ai35
	G4	card 1:ai36
	G5	card 1:ai37
	T	card 1:ai38
4	G0	card 1:ai48
	G1	card 1:ai49
	G2	card 1:ai50
	G3	card 1:ai51
	G4	card 1:ai52
	G5	card 1:ai53
	T	card 1:ai54
5	G0	card 2:ai0
	G1	card 2:ai1
	G2	card 2:ai2
	G3	card 2:ai3
	G4	card 2:ai4
	G5	card 2:ai5
6	T	card 2:ai6
	G0	card 2:ai16
	G1	card 2:ai17
	G2	card 2:ai18
	G3	card 2:ai19
	G4	card 2:ai20
	G5	card 2:ai21
T	card 2:ai22	

Table 9.36—Transducer Channel Assignment for 9105-IFPS-6 and 9105-IFPS-6-E

BNC Connector	NI Signal
Center	ExtStrobe
Outside	DGnd

Table 9.37—BNC Connector Signals

DB50 Pin	NI Signal
18	card 2:ai32
19	card 2:ai40
20	card 2:ai33
21	card 2:ai41
22	card 2:ai34
23	card 2:ai42
24	card 2:ai35
25	card 2:ai43
26	card 2:ai36
27	card 2:ai44
28	card 2:ai37
29	card 2:ai45
30	card 2:ai38
31	card 2:ai46
32	card 2:ai39
33	card 2:ai47
34	card 2:ai48
35	card 2:ai56
36	card 2:ai49
37	card 2:ai57
38	card 2:ai50
39	card 2:ai58
40	card 2:ai51
41	card 2:ai59
42	card 2:ai52
43	card 2:ai60
44	card 2:ai53
45	card 2:ai61
46	card 2:ai54
47	card 2:ai62
48	card 2:ai55
49	card 2:ai63
17	AIgnd
50	AI Sense2

Table 9.38—User Channel Connector for 9105-IFPS-6-E. DB50 pins not listed are unused

Note: All channels and signals reflect National Instruments' nomenclature. Check NI's documentation for information about using differential channels.

9.2.10 9105-IFPS-7 and 9105-IFPS-7-E Signal Allocation

Transducer	Signal	NI Differential Channel
1	G0	card 1:ai0
	G1	card 1:ai1
	G2	card 1:ai2
	G3	card 1:ai3
	G4	card 1:ai4
	G5	card 1:ai5
	T	card 1:ai6
2	G0	card 1:ai16
	G1	card 1:ai17
	G2	card 1:ai18
	G3	card 1:ai19
	G4	card 1:ai20
	G5	card 1:ai21
	T	card 1:ai22
3	G0	card 1:ai32
	G1	card 1:ai33
	G2	card 1:ai34
	G3	card 1:ai35
	G4	card 1:ai36
	G5	card 1:ai37
	T	card 1:ai38
4	G0	card 1:ai48
	G1	card 1:ai49
	G2	card 1:ai50
	G3	card 1:ai51
	G4	card 1:ai52
	G5	card 1:ai53
	T	card 1:ai54
5	G0	card 2:ai0
	G1	card 2:ai1
	G2	card 2:ai2
	G3	card 2:ai3
	G4	card 2:ai4
	G5	card 2:ai5
	T	card 2:ai6
6	G0	card 2:ai16
	G1	card 2:ai17
	G2	card 2:ai18
	G3	card 2:ai19
	G4	card 2:ai20
	G5	card 2:ai21
	T	card 2:ai22

Transducer	Signal	NI Differential Channel
7	G0	card 2:ai16
	G1	card 2:ai17
	G2	card 2:ai18
	G3	card 2:ai19
	G4	card 2:ai20
	G5	card 2:ai21
	T	card 2:ai22

Table 9.39—Transducer Channel Assignment for 9105-IFPS-7 and 9105-IFPS-7-E

BNC Connector	NI Signal
Center	ExtStrobe
Outside	DGnd

Table 9.40—BNC Connector Signals

DB50 Pin	NI Signal
34	card 2:ai48
35	card 2:ai56
36	card 2:ai49
37	card 2:ai57
38	card 2:ai50
39	card 2:ai58
40	card 2:ai51
41	card 2:ai59
42	card 2:ai52
43	card 2:ai60
44	card 2:ai53
45	card 2:ai61
46	card 2:ai54
47	card 2:ai62
48	card 2:ai55
49	card 2:ai63
17	AIgnd
50	AI Sense2

Table 9.41—User Channel Connector for 9105-IFPS-7-E. DB50 pins not listed are unused

Note: All channels and signals reflect National Instruments' nomenclature. Check NI's documentation for information about using differential channels.

9.2.11 9105-IFPS-8 Signal Allocation

Transducer	Signal	NI Differential Channel	Transducer	Signal	NI Differential Channel
1	G0	card 1:ai0	5	G0	card 2:ai0
	G1	card 1:ai1		G1	card 2:ai1
	G2	card 1:ai2		G2	card 2:ai2
	G3	card 1:ai3		G3	card 2:ai3
	G4	card 1:ai4		G4	card 2:ai4
	G5	card 1:ai5		G5	card 2:ai5
	T	card 1:ai6		T	card 2:ai6
2	G0	card 1:ai16	6	G0	card 2:ai16
	G1	card 1:ai17		G1	card 2:ai17
	G2	card 1:ai18		G2	card 2:ai18
	G3	card 1:ai19		G3	card 2:ai19
	G4	card 1:ai20		G4	card 2:ai20
	G5	card 1:ai21		G5	card 2:ai21
	T	card 1:ai22		T	card 2:ai22
3	G0	card 1:ai32	7	G0	card 2:ai32
	G1	card 1:ai33		G1	card 2:ai33
	G2	card 1:ai34		G2	card 2:ai34
	G3	card 1:ai35		G3	card 2:ai35
	G4	card 1:ai36		G4	card 2:ai36
	G5	card 1:ai37		G5	card 2:ai37
	T	card 1:ai38		T	card 2:ai38
4	G0	card 1:ai48	8	G0	card 2:ai48
	G1	card 1:ai49		G1	card 2:ai49
	G2	card 1:ai50		G2	card 2:ai50
	G3	card 1:ai51		G3	card 2:ai51
	G4	card 1:ai52		G4	card 2:ai52
	G5	card 1:ai53		G5	card 2:ai53
	T	card 1:ai54		T	card 2:ai54

Table 9.42—Transducer Channel Assignment for 9105-IFPS-8

BNC Connector	NI Signal
Center	ExtStrobe
Outside	DGnd

Table 9.43—BNC Connector Signals

Note: All channels and signals reflect National Instruments' nomenclature. Check NI's documentation for information about using differential channels.

10. Appendix B—Drawings

10.1 9105-PS-1

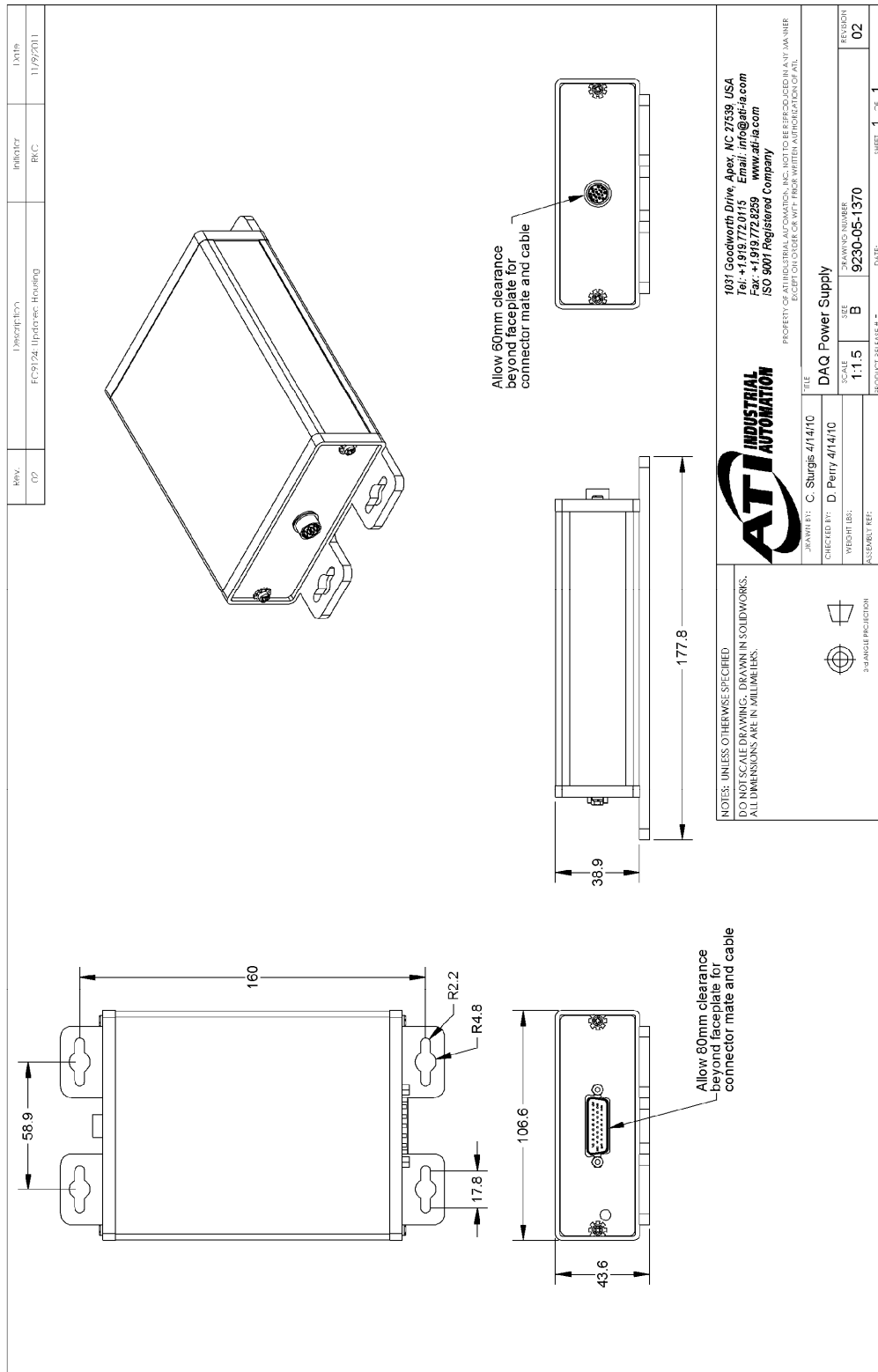

10.2 9105-IFPS-1

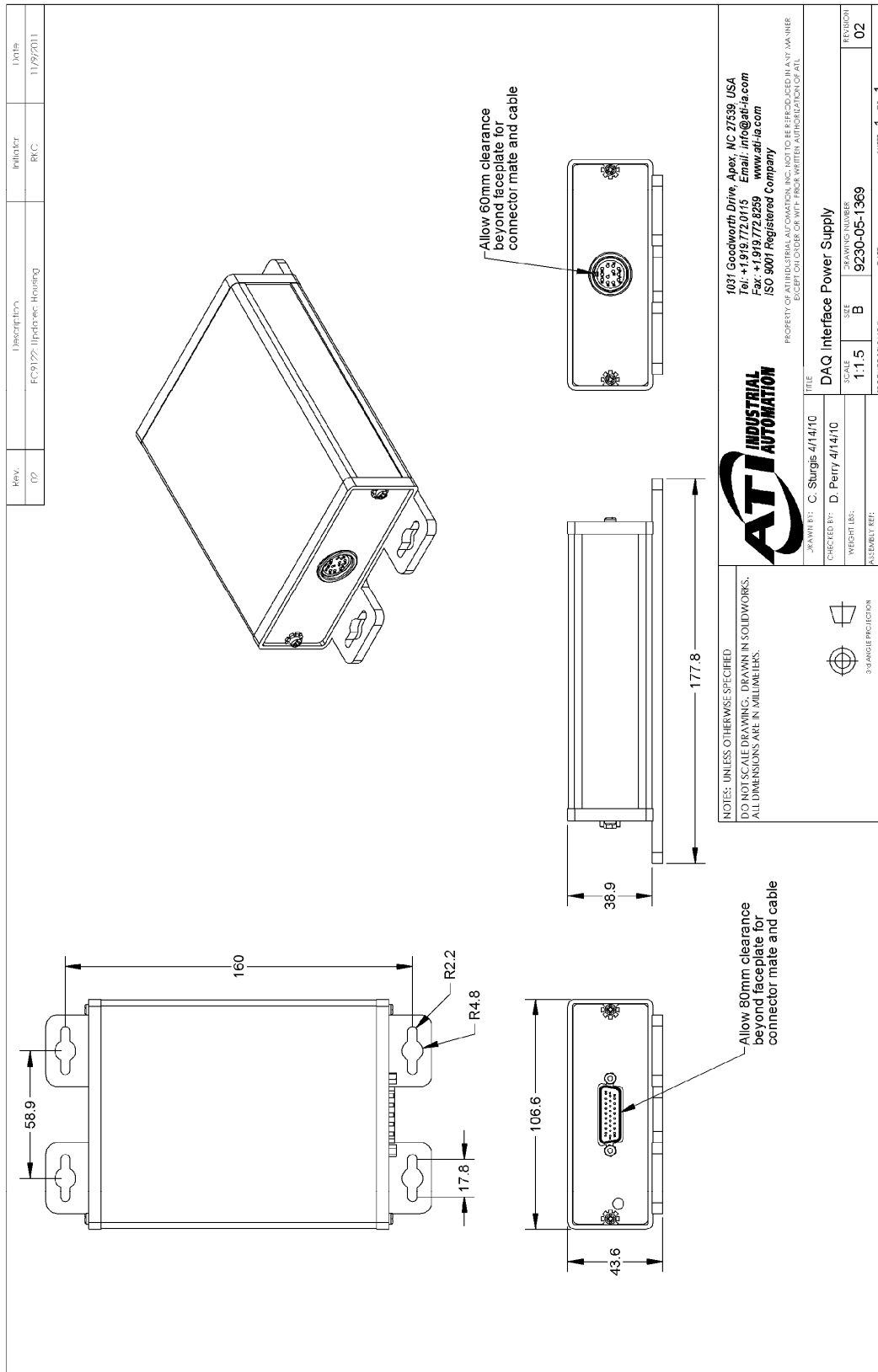

10.3 9105-IFPSMC Multiple IFPS Box

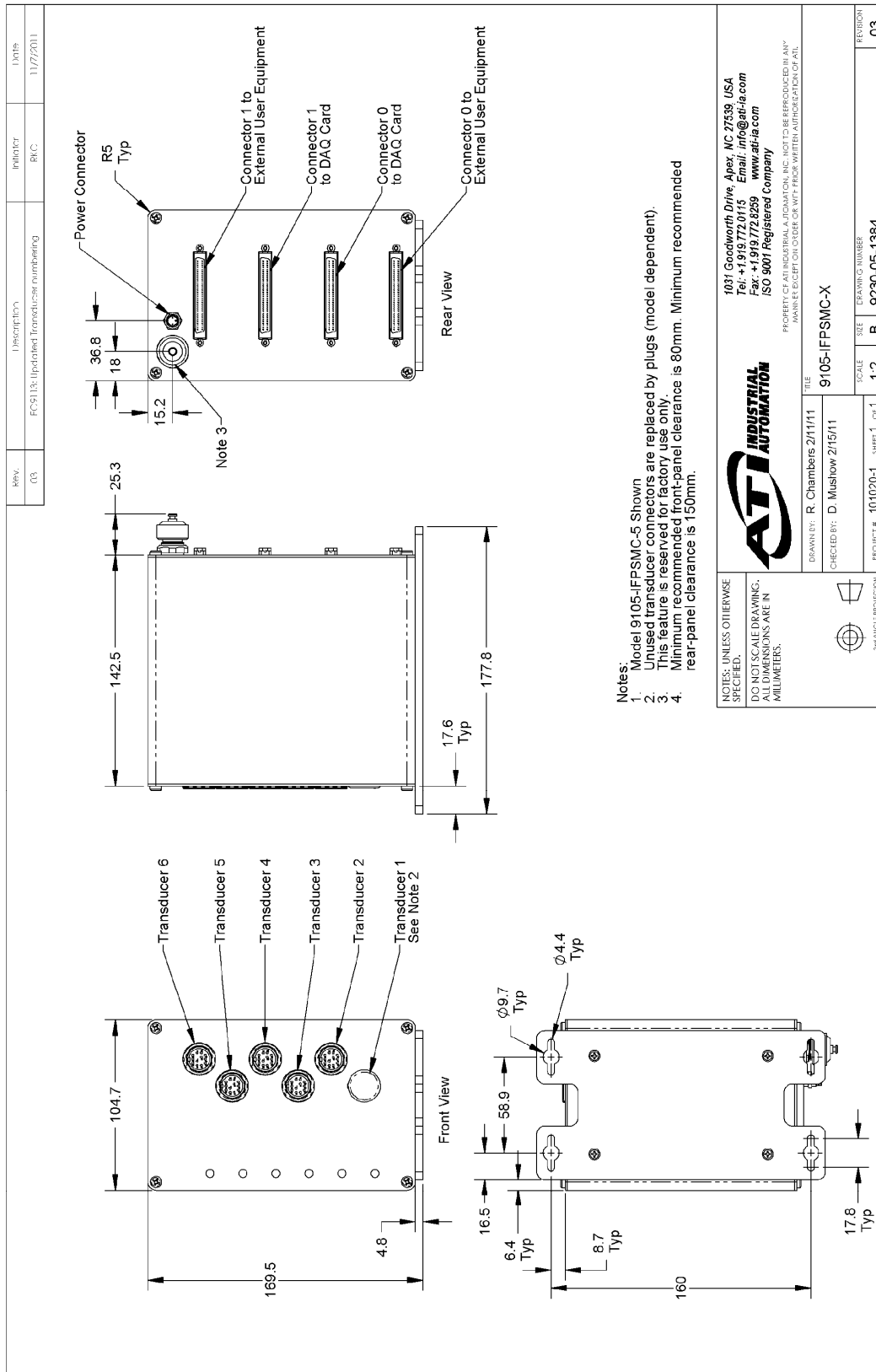

- Notes:**
1. Model 9105-IFPSMC-5 Shown
 2. Unused transducer connectors are replaced by plugs (model dependent). This feature is reserved for factory use only.
 3. Minimum recommended front-panel clearance is 80mm. Minimum recommended rear-panel clearance is 150mm.
 - 4.

REV. 03		DESCRIPTION FC9113: Updated Transducer numbering		INITIATOR RAC	DATE 11/7/2011
		1031 Goodworth Drive, Apex, NC 27539, USA Tel: +1-919-772-0115 Email: info@ati-ia.com Fax: +1-919-772-8259 www.ati-ia.com ISO 9001 Registered Company		PROPERTY OF AT INDUSTRIAL AUTOMATION, INC. NOT TO BE REPRODUCED IN ANY MANNER WITHOUT WRITTEN AUTHORIZATION OF ATi	
DRAWN BY: R. Chambers 2/11/11 CHECKED BY: D. Mustlow 2/15/11		TITLE 9105-IFPSMC-X		SCALE 1:2 SHEET 1 OF 1	
PROJECT # 101020-1		DRAWING NUMBER B 9230-05-1384		REVISION 03	

10.4 Multiple IFPS

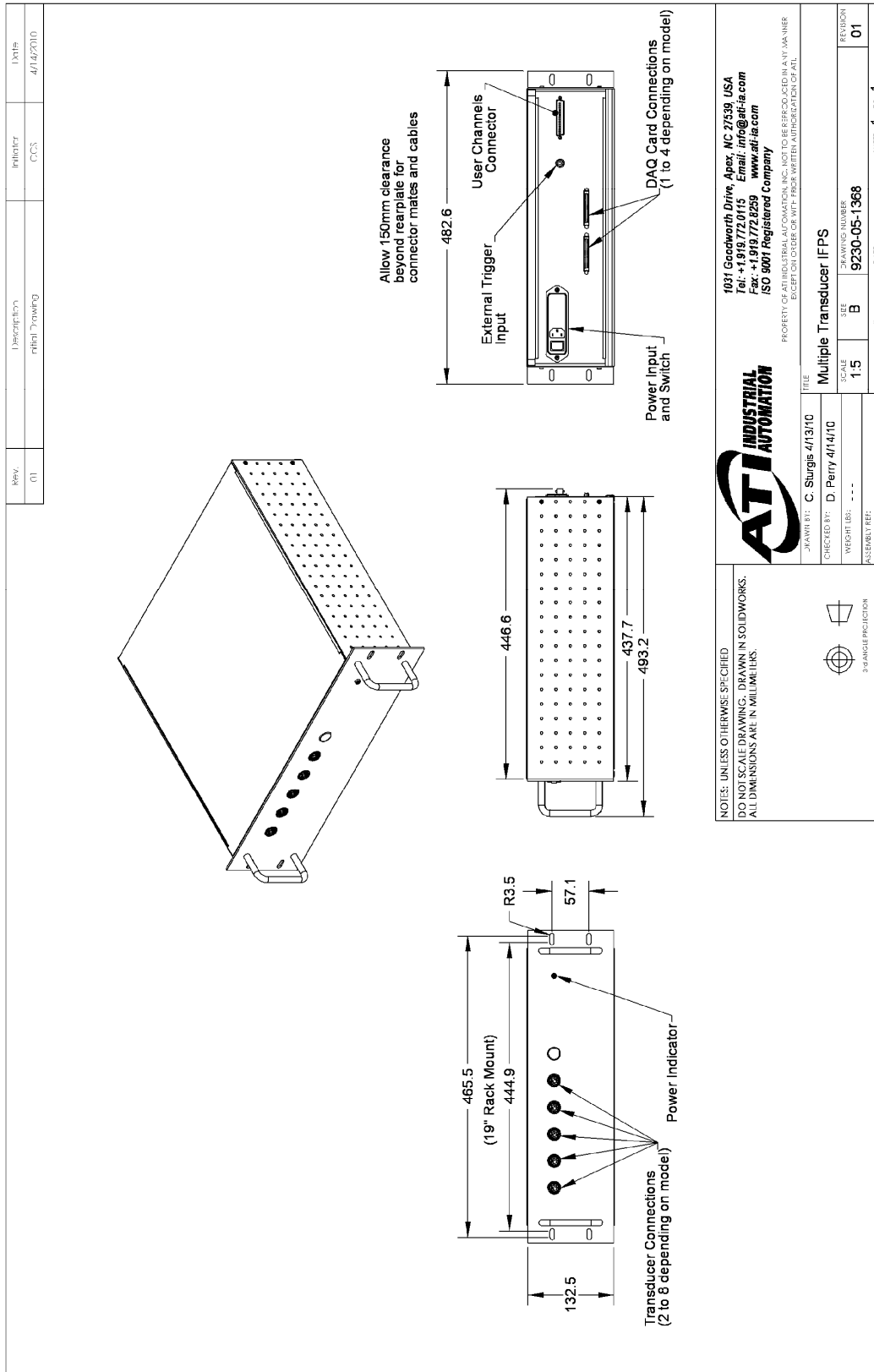

11. Terms and Conditions of Sale

The following Terms and Conditions are a supplement to and include a portion of ATI's Standard Terms and Conditions, which are on file at ATI and available upon request.

ATI warrants to Purchaser that force torque sensor products purchased hereunder will be free from defects in material and workmanship under normal use for a period of one year from the date of shipment. This warranty does not cover components subject to wear and tear under normal usage or those requiring periodic replacement. ATI will have no liability under this warranty unless: (a) ATI is given written notice of the claimed defect and a description thereof within thirty (30) days after Purchaser discovers the defect and in any event not later than the last day of the warranty period; and (b) the defective item is received by ATI not later ten (10) days after the last day of the warranty period. ATI's entire liability and Purchaser's sole remedy under this warranty is limited to repair or replacement, at ATI's election, of the defective part or item or, at ATI's election, refund of the price paid for the item. The foregoing warranty does not apply to any defect or failure resulting from improper installation, operation, maintenance or repair by anyone other than ATI.

ATI will in no event be liable for incidental, consequential or special damages of any kind, even if ATI has been advised of the possibility of such damages. ATI's aggregate liability will in no event exceed the amount paid by purchaser for the item which is the subject of claim or dispute. ATI will have no liability of any kind for failure of any equipment or other items not supplied by ATI.

No action against ATI, regardless of form, arising out of or in any way connected with products or services supplied hereunder may be brought more than one year after the cause of action accrued.

No representation or agreement varying or extending the warranty and limitation of remedy provisions contained herein is authorized by ATI, and may not be relied upon as having been authorized by ATI, unless in writing and signed by an executive officer of ATI.

Unless otherwise agreed in writing by ATI, all designs, drawings, data, inventions, software and other technology made or developed by ATI in the course of providing products and services hereunder, and all rights therein under any patent, copyright or other law protecting intellectual property, shall be and remain ATI's property. The sale of products or services hereunder does not convey any express or implied license under any patent, copyright or other intellectual property right owned or controlled by ATI, whether relating to the products sold or any other matter, except for the license expressly granted below.

In the course of supplying products and services hereunder, ATI may provide or disclose to Purchaser confidential and proprietary information of ATI relating to the design, operation or other aspects of ATI's products. As between ATI and Purchaser, ownership of such information, including without limitation any computer software provided to Purchaser by ATI, shall remain in ATI and such information is licensed to Purchaser only for Purchaser's use in operating the products supplied by ATI hereunder in Purchaser's internal business operations.

Without ATI's prior written permission, Purchaser will not use such information for any other purpose or provide or otherwise make such information available to any third party. Purchaser agrees to take all reasonable precautions to prevent any unauthorized use or disclosure of such information.

Purchaser will not be liable hereunder with respect to disclosure or use of information which: (a) is in the public domain when received from ATI; (b) is thereafter published or otherwise enters the public domain through no fault of Purchaser; (c) is in Purchaser's possession prior to receipt from ATI; (d) is lawfully obtained by Purchaser from a third party entitled to disclose it; or (f) is required to be disclosed by judicial order or other governmental authority, provided that, with respect to such required disclosures, Purchaser gives ATI prior notice thereof and uses all legally available means to maintain the confidentiality of such information.



***F/T* Transducer**

**Six-Axis
Force/Torque Transducer**

Installation and Operation Manual



Document # 9620-05-Transducer Section
August 2011

Engineered Products for Robotic Productivity

Pinnacle Park 1031 Goodworth Drive Apex, NC 27539 USA Tel: +1.919.772.0115 Fax: +1.919.772.8259 www.ati-ia.com Email: info@ati-ia.com

Forward

Information contained in this document is the property of ATI Industrial Automation, Inc. and shall not be reproduced in whole or in part without prior written approval of ATI Industrial Automation, Inc. The information herein is subject to change without notice and should not be construed as a commitment on ATI Industrial Automation, Inc. This manual is periodically revised to reflect and incorporate changes made to the F/T system.

ATI Industrial Automation, Inc. assumes no responsibility for any errors or omissions in this document. Users' critical evaluation is welcome to assist in the preparation of future documentation (see the *What Do You Think* section at the end of this manual).

Copyright © by ATI Industrial Automation, Inc., Apex, North Carolina USA. All Rights Reserved.
Published in the USA.

In consideration that ATI Industrial Automation, Inc. (ATI) products are intended for use with robotic and/or automated machines, ATI does not recommend the use of its products for applications wherein failure or malfunction of an ATI component or system threatens life or makes injury probable. Anyone who uses or incorporates ATI components within any potentially life threatening system must obtain ATI's prior consent based upon assurance to ATI that a malfunction of ATI's component does not pose direct or indirect threat of injury or death, and (even if such consent is given) shall indemnify ATI from any claim, loss, liability, and related expenses arising from any injury or death resulting from use of ATI components.

*All trademarks belong to their respective owners.
Windows is a registered trademark of Microsoft Corporation.*

FCC Compliance - Class A

This device complies with Part 15 of the FCC Rules. Operation is subject to the following two conditions: (1) this device may not cause harmful interference, and (2) this device must accept any interference received, including interference that may cause undesired operation.

CE Conformity

CTL Transducers

This device complies with EMC Directive 89/336/EEC and conforms to the following standards: EN50081-1:1992, EN50082-1:1992, CISPR 22:1993 (EN55022:1994), IEC 1000-4-2:1995, IEC 1000-4-3:1995, IEC 1000-4-4:1995

DAO Transducers

This device complies with EMC Directive 89/336/EEC and conforms to the following standards: EN55011:1998, ANSI C63.4:1992, EN61000-4-2:1995, EN61000-4-3:1995, EN61000-4-4:1995, EN61000-4-6:1995.

TWE Transducers

This device complies with EMC Directive 89/336/EEC and conforms to the following standards: EN50081-1:1992, EN50082-1:1992, CISPR 22:1993 (EN55022:1994), IEC 1000-4-2:1995, IEC 1000-4-3:1995, IEC 1000-4-4:1995

Aside

Please read the manual before calling customer service. Before calling, have the following information available:

1. Serial number (e.g.; FT01234)
2. Transducer model (e.g.; Nano17, Gamma, Theta, etc.)
3. Calibration (e.g.; US-15-50/S, SI-65-6/S, etc.)
4. Accurate and complete description of the question or problem
5. Computer and software information. Operating system, PC type, drivers, application software and other relevant information about your configuration.

If possible, have access to the F/T system when calling.

How to Reach Us

Sales, Service and Information about ATI products:

ATI Industrial Automation

1031 Goodworth Drive
Apex, NC 27539 USA
www.ati-ia.com

Tel: +1.919.772.0115

Fax: +1.919.772.8259

E-mail: info@ati-ia.com

Technical support and questions:

Application Engineering

Tel: +1.919.772.0115, Option 2, Option 2

Fax: +1.919.772.8259

E-mail: ft_support@ati-ia.com

Table of Contents

1. Safety	9
1.1 General	9
1.2 Explanation of Warnings	9
1.3 Precautions	9
2. Installation	10
2.1 Introduction	10
2.2 Routing the Transducer Cable	10
2.3 Transducer Environment	11
2.4 Mounting the Transducer	11
2.4.1 Transducer Mounting Method I, Standard Adapter (summary)	11
2.4.2 Transducer Mounting Method II, Ring-Plug Adapter (summary)	11
2.4.3 Transducer Mounting Method III, User-Designed Interface (summary)	12
2.4.4 Transducer Mounting Method I, Standard Adapter	12
2.4.5 Transducer Mounting Method II, Ring-plug Adapter	13
2.4.6 Transducer Mounting Method III, User-designed Interface	14
2.5 Mounting Your Tool	15
2.5.1 Tool Mounting Method I, Standard Tool Adapter	15
2.5.2 Tool Mounting Method II, Optional Tool Ring-plug Adapter	15
3. Topics	16
3.1 Accuracy over Temperature	16
3.2 Tool Transformation Effects	16
3.3 Environmental	17
3.4 Mux Transducer Input Filter Frequency Response	17
3.5 Transducer Strain Gage Saturation	18
4. Transducer Specifications	19
4.1 Notes	19
4.1.1 About CTL Calibration Specifications	19
4.1.2 Complex Loading Graph Description	19
4.2 Nano17 Titanium	20
4.2.1 Calibration Specifications (excludes CTL calibrations)	20
4.2.2 CTL Calibration Specifications	21
4.2.3 Nano17 Titanium Physical Properties	22
4.2.4 Nano17 Titanium (US Calibration Complex Loading)	23
4.2.5 Nano17 Titanium (SI Calibration Complex Loading)	24
4.2.6 Nano17 Titanium Transducer Drawing	25
4.3 Nano17 (Includes IP65/IP68 Versions)	26
4.3.1 Calibration Specifications (excludes CTL calibrations)	26
4.3.2 CTL Calibration Specifications	27
4.3.3 Nano17 Physical Properties	29
4.3.4 Nano17 (US Calibration Complex Loading)	30
4.3.5 Nano17 (SI Calibration Complex Loading)	31
4.3.6 Nano17-E Transducer	32
4.3.7 Nano17 IP65/IP68 Transducer with Axial Cable Exit	33

F/T Transducer Installation and Operation Manual

Document #9620-05-transducer section-15

4.3.8	Legacy Nano17 Transducer	34
4.4	Nano25—(Includes IP65/IP68 Versions).....	35
4.4.1	Calibration Specifications (excludes CTL calibrations)	35
4.4.2	CTL Calibration Specifications	36
4.4.3	Nano25 Physical Properties (Includes IP65/IP68 Versions)	37
4.4.4	Nano25 (US Calibration Complex Loading) (Includes IP65/IP68 Versions)	39
4.4.5	Nano25 (SI Calibration Complex Loading) (Includes IP65/IP68 Versions)	40
4.4.6	Nano25-E Transducer	41
4.4.7	Nano25 IP65/IP68 Transducer with Axial Cable Exit	42
4.4.8	Nano25 IP65/IP68 Transducer with Radial Cable Exit.....	43
4.4.9	Legacy Nano25 Transducer	44
4.5	Nano43	45
4.5.1	Calibration Specifications (excludes CTL calibrations)	45
4.5.2	CTL Calibration Specifications	46
4.5.3	Nano43 Physical Properties	47
4.5.4	Nano43 (US Calibration Complex Loading)	48
4.5.5	Nano43 (SI Calibration Complex Loading)	49
4.5.6	Nano43 Transducer	50
4.6	Mini40	51
4.6.1	Calibration Specifications (excludes CTL calibrations)	51
4.6.2	CTL Calibration Specifications	52
4.6.3	Mini40 Physical Properties	53
4.6.4	Mini40 (US Calibration Complex Loading)	54
4.6.5	Mini40 (SI Calibration Complex Loading)	55
4.6.6	Mini40-E Transducer	56
4.6.7	Legacy Mini40 Transducer	57
4.7	Mini45	58
4.7.1	Calibration Specifications (excludes CTL calibrations)	58
4.7.2	CTL Calibration Specifications	59
4.7.3	Mini45 Physical Properties	60
4.7.4	Mini45 (US Calibration Complex Loading)	61
4.7.5	Mini45 (SI Calibration Complex Loading)	62
4.7.6	Mini45-E Transducer	63
4.7.7	Legacy Mini45 Transducer	64
4.8	Mini85	65
4.8.1	Calibration Specifications (excludes CTL calibrations)	65
4.8.2	CTL Calibration Specifications	66
4.8.3	Mini85 Physical Properties	67
4.8.4	Mini85 (US Calibration Complex Loading)	68
4.8.5	Mini85 (SI Calibration Complex Loading)	69
4.8.6	Mini85-E Transducer	70
4.9	Gamma (Includes IP60/IP65 Versions)	71
4.9.1	Calibration Specifications (excludes CTL calibrations)	71
4.9.2	CTL Calibration Specifications	72
4.9.3	Gamma Physical Properties	73
4.9.4	Gamma (US Calibration Complex Loading) (Includes IP60/IP65 Version)	74
4.9.5	Gamma (SI Calibration Complex Loading) (Includes IP60/IP65 Version).....	75
4.9.6	Gamma DAQ/Net Transducer	76

4.9.7	9105-T-Gamma Transducer without Mounting Adapter	77
4.9.8	Gamma Mounting Adapter Plate	78
4.9.9	Gamma Tool Ring-plug Adapter	79
4.9.10	Gamma IP60 Transducer	80
4.9.11	Gamma Mounting Ring-plug Adapter	81
4.9.12	Gamma IP65 Transducer	82
4.10	Delta (Includes IP60/IP65/IP68 Versions)	83
4.10.1	Calibration Specifications (excludes CTL calibrations)	83
4.10.2	CTL Calibration Specifications	84
4.10.3	Delta Physical Properties (Includes IP60/IP65/IP68 Versions)	85
4.10.4	Delta (US Calibration Complex Loading) (Includes IP60/IP65/IP68 Versions)	87
4.10.5	Delta (SI Calibration Complex Loading) (Includes IP60/IP65/IP68 Versions)	88
4.10.6	Delta DAQ/Net Transducer	89
4.10.7	9105-T-Delta Transducer without Mounting Adapter	90
4.10.8	Delta Mounting Adapter	91
4.10.9	Delta Tool Ring-plug Adapter	92
4.10.10	Delta Mounting Ring-plug Adapter	93
4.10.11	Delta IP60 Transducer	94
4.10.12	Delta IP65 Transducer	95
4.10.13	Delta IP68 Transducer	96
4.11	Theta (Includes IP60/IP65/IP68 Versions)	97
4.11.1	Calibration Specifications (excludes CTL calibrations)	97
4.11.2	CTL Calibration Specifications	98
4.11.3	Theta Physical Properties (Includes IP60/IP65/IP68 Versions)	99
4.11.4	Theta (US Calibration Complex Loading) (Includes IP60/IP65/IP68 Versions)	101
4.11.5	Theta (SI Calibration Complex Loading) (Includes IP60/IP65/IP68 Versions)	102
4.11.6	Theta DAQ/Net Transducer	103
4.11.7	9105-T-Theta Transducer without Mounting Adapter Plate	104
4.11.8	Theta Mounting Adapter Plate	105
4.11.9	Theta IP60 Transducer	106
4.11.10	Theta IP65 Transducer	107
4.11.11	Theta IP68 Transducer	108
4.12	Omega160 (Includes IP60/IP65/IP68 Versions)	109
4.12.1	Calibration Specifications (excludes CTL calibrations)	109
4.12.2	CTL Calibration Specifications	110
4.12.3	Omega160 Physical Properties (Includes IP60/IP65/IP68 Versions)	111
4.12.4	Omega160 (US Calibration Complex Loading) (Includes IP60/IP65/IP68 Versions)	113
4.12.5	Omega160 (SI Calibration Complex Loading) (Includes IP60/IP65/IP68 Versions)	114
4.12.6	Omega160 Transducer with Mounting Adapter Plate	115
4.12.7	Omega160 IP60 Transducer	116
4.12.8	Omega160 IP65 Transducer	118
4.12.9	Omega160 IP68 Transducer	119
4.13	Omega190 (Includes IP60/IP65/IP68 Versions)	120
4.13.1	Calibration Specifications (excludes CTL calibrations)	120
4.13.2	CTL Calibration Specifications	121
4.13.3	Omega190 Physical Properties (Includes IP60/IP65/IP68 Versions)	122
4.13.4	Omega190 (US Calibration Complex Loading) (Includes IP60/IP65/IP68 Versions)	124
4.13.5	Omega190 (SI Calibration Complex Loading) (Includes IP60/IP65/IP68 Versions)	125

4.13.6	Omega190 Transducer.....	126
4.13.7	Omega190 IP60 Transducer	127
4.13.8	Omega190 IP65 Transducer	128
4.13.9	Omega190 IP68 Transducer	129
4.14	Omega250 (Includes IP60/IP65/IP68 Versions)	130
4.14.1	Calibration Specifications (excludes CTL calibrations)	130
4.14.2	CTL Calibration Specifications	131
4.14.3	Omega250 Physical Properties (Includes IP60/IP65/IP68 Versions).....	132
4.14.4	Omega250 (US Calibration Complex Loading) (Includes IP60/IP65/IP68 Versions).....	134
4.14.5	Omega250 (SI Calibration Complex Loading) (Includes IP60/IP65/IP68 Versions)	135
4.14.6	Omega250 IP60 Transducer	136
4.14.7	Omega250 IP65 Transducer	137
4.14.8	Omega250 IP68 Transducer	138
4.15	Omega331	139
4.15.1	Calibration Specifications (excludes CTL calibrations)	139
4.15.2	CTL Calibration Specifications	140
4.15.3	Omega331 Physical Properties (Includes IP60/IP65/IP68 Versions).....	141
4.15.4	Omega331 (US Calibration Complex Loading)	142
4.15.5	Omega331 (SI Calibration Complex Loading).....	143
4.15.6	Omega331 Transducer.....	144
5.	Advanced Topics	145
5.1	Reducing Noise	145
5.1.1	Mechanical Vibration	145
5.1.2	Electrical Interference	145
5.2	Detecting Failures (Diagnostics)	145
5.2.1	Detecting Sensitivity Changes.....	145
5.3	Scheduled Maintenance	145
5.3.1	Periodic Inspection	145
5.3.2	Periodic Calibration.....	146
5.4	Transducer Cabling	146
5.4.1	Calibrations	146
5.4.2	Connectors	146
5.5	A Word about Resolution	146
6.	Terms and Conditions of Sale.....	147

Glossary of Terms

Terms	Conditions
Accuracy	See <i>Measurement Uncertainty</i> .
Compound Loading	Any load that is not purely in one axis.
CTL	Denotes transducers and systems that use the F/T Controller interface.
DAQ	Denotes transducers and systems that use the data acquisition interface.
FS	F ull- S cale.
F/T	F orce and T orque.
Fxy	The resultant force vector comprised of components Fx and Fy.
Hysteresis	A source of measurement caused by the residual effects of previously applied loads.
IFPS	I nter F ace/ P ower S upply box.
IP60	Ingress Protection rating 60 designates protection against dust.
IP65	Ingress Protection rating 65 designates protection against water spray.
IP68	Ingress Protection rating 68 designates submergibility in fresh water, in this case to a depth of 10 meters.
LabVIEW	A graphical programming environment created for data acquisition tasks by National Instruments.
Maximum Single-Axis Overload	The largest amount of pure load (not compound loading) that the transducer can withstand without damage.
MAP	M ounting A dapter P late. The transducer plate that attaches to the fixed surface or robot arm.
Measurement Uncertainty	The maximum expected error in measurements, as specified on the calibration certificate.
Mux Box	The component that contains transducer electronics for transducers that are too small to house them.
NI	N ational I nstruments Corporation, the owner of the <i>National Instruments</i> and <i>LabVIEW</i> trademarks. (www.ni.com)
Overload	The condition where more load is applied to the transducer than it can measure. This will result in saturation.
PC Card	A small computer card for use in most laptop computers.
PCMCIA Card	See <i>PC Card</i> . (<i>PCMCIA</i> has been renamed <i>PC Card</i> by its standards organization).
Point of Origin	The point on the transducer from which all forces and torques are measured.
PS	P ower S upply box.
Quantization	The process of converting a continuously variable transducer signal into discrete digital values. Usually used when describing the change from one digital value to the next.
Resolution	The smallest change in load that can be measured. This is usually much smaller than accuracy.
Saturation	The condition where the transducer or data acquisition hardware has a load or signal outside of its sensing range.
Sensor System	The entire assembly consisting of parts from transducer to controller.
TAP	T ool A dapter P late. The transducer surface that attaches to the load to be measured.
TWE	Denotes transducers that require user-amplification and data acquisition.
Tool Transformation	A method of mathematically shifting the measurement coordinate system resulting in a translated origin and/or rotated axes.
Transducer	The component that converts the sensed load into electrical signals.
Txy	The resultant torque vector comprised of components Tx and Ty.
Visual Basic	A Microsoft programming environment for developing Windows [®] -based applications.

1. Safety

1.1 General

The customer should verify that the transducer selected is rated for the maximum loads and moments expected during operation. Refer to transducer specifications in Section 4 of this manual or contact ATI for assistance. Particular attention should be paid to dynamic loads caused by robot acceleration and deceleration. These forces can be many times the value of static forces in high acceleration or deceleration situations.

1.2 Explanation of Warnings

The warnings included here are specific to the product(s) covered by this manual. It is expected that the user heed all warnings from the robot manufacturer and/or the manufacturers of other components used in the installation.



Danger indicates that a situation could result in potentially serious injury or damage to equipment.



Caution indicates that a situation could result in damage to the product and/or the other system components.

1.3 Precautions



DANGER: Do not attempt to disassemble the transducer. This will damage the instrumentation.



DANGER: Do not probe any openings in the transducer. This will damage the instrumentation.



DANGER: Take care to prevent excessive forces or moments from being applied to the transducer during handling or installation. The small Nano series is easily overloaded during rough handling and may be damaged.

2. Installation

2.1 Introduction

This section will assist the user in mounting the transducer, your tool, and the transducer cable.

2.2 Routing the Transducer Cable

The transducer cable must be routed so that it is not stressed, pulled, kinked, cut, or otherwise damaged throughout the full range of motion. See the accompanying system manual for the transducer cable interfacing. If the desired application results in the cable rubbing, then use a loose plastic spiral wrap for protection.

 **CAUTION:** When the cable is cycling below the minimum bending radius, the cable may fail due to fatigue. A smaller radius can be used if it is not being cycled.

The minimum cycled bending radius is different with significant temperature changes, increasing with lower temperature and decreasing for higher temperature.

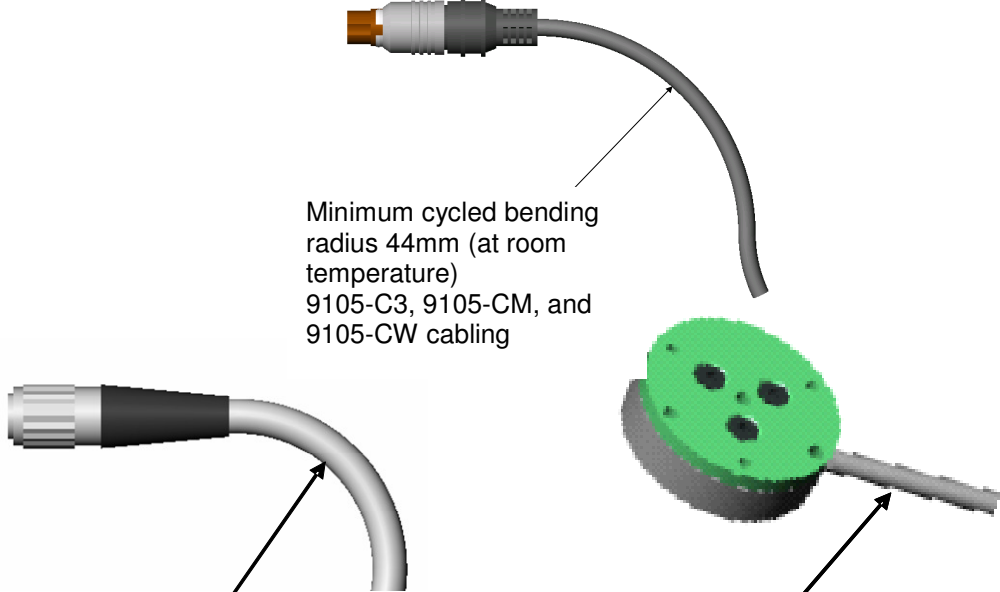

Minimum cycled bending radius 44mm (at room temperature)
9105-C3, 9105-CM, and 9105-CW cabling

Minimum cycled bending radius 61mm (at room temperature)
9105-CT and 9105-C cabling

Minimum cycled bending radius 32mm (at room temperature)
9105-TW Transducers with integral cable

 **CAUTION:** Do not stress or over bend the transducer cable, especially where it is attached to the transducer. This is particularly important on the Nano and Mini series of transducers. For these transducers, do not bend the cable any closer than 25mm (1 inch) to the transducer. Sharp bends must be avoided as they can damage the cable and transducer and will void the warranty.

 **CAUTION:** Be careful not to crush the cable by over-tightening tie wraps or walking on the cable, since this may damage the cable.



CAUTION:

Cables on the Nano and Mini transducers are permanently attached to the transducer and cannot be disconnected. Do not attempt to disassemble these transducers as damage will occur.

Larger transducers have removable cables. Do not attempt to disconnect these transducer cables by pulling on the cable itself or the connector boot; this can damage your system.



CAUTION: Nano and Mini integral cables and cables of the 9105-C-H type must not subject the transducer end connection to more than 10 lbf (45 N) of side-to-side or pull force or permanent damage will result.

2.3 Transducer Environment

To ensure proper operation, the IP rating of the transducer must match or exceed the transducer's environment. Unless otherwise specified, a transducer has no special IP protection. In this case, the transducer may be used only in benign environments with no dust or debris and no liquids or spray.



CAUTION: Transducers without an IP protection may exhibit a small offset in readings when exposed to strong light.



CAUTION: Transducers may react to exceptionally strong and changing electromagnetic fields, such as those produced by magnetic resonance (MRI) imaging machines.

Section 2.1 contains information on the transducer's temperature performance.

2.4 Mounting the Transducer

There are three different methods, I, II, and III, for mounting most F/T transducers. Mount the transducer to a structure with sufficient mechanical strength. Not doing so can lead to sub-optimum performance. **The Nano, Mini, Omega, and IP-rated transducers have mounting and tool adapters which cannot be removed, so only Method III can be used.** A detailed description of each method is given on the following pages and a brief description is given below.

2.4.1 Transducer Mounting Method I, Standard Adapter (summary)

Mounting Method I uses the standard mounting adapter to attach the transducer. This method is only available for transducers with customer-removable mounting adapter plates. You must machine the bolt pattern of your device (i.e.; robot) into the transducer's mounting adapter plate. You will not be able to use the mounting adapter alone if your device covers the mounting screws used to connect the transducer. If this is the case, use either Method II or Method III instead.

2.4.2 Transducer Mounting Method II, Ring-Plug Adapter (summary)

Mounting Method II uses the optional mounting ring-plug adapter as a replacement for the standard mounting adapter. You must machine the mounting plug to attach to

your device. The mounting ring-plug adapter has the benefit of allowing the transducer to be connected and disconnected by hand (disconnecting may require a strap wrench). If the bolt pattern on your device can fit on the plug and you have access to the ring, then the mounting ring-plug adapter will work. If the bolt pattern is larger than the plug, use Method III.

2.4.3 Transducer Mounting Method III, User-Designed Interface (summary)

Mounting Method III uses your own interface plate to bolt directly to the transducer or (for the Nano, Mini, or Omega models) the mounting adapter.

The *Section 4—Transducer Specifications* contains detailed mechanical drawings of the transducer and all interface plates. Detailed descriptions of each method are shown on the next two pages.

Aside:

Examine the sensor frame and cable routing section before modifying the mounting adapter plates. The F/T system's default sensor frame sets the transducer's point-of-origin at the center of the mounting adapter's surface. See *Section 4—Transducer Specifications*, for drawings showing the default point of origin.

2.4.4 Transducer Mounting Method I, Standard Adapter

Use the mounting adapter to attach the transducer as follows:

- Ensure that you provide sufficient clearances between the mounted transducer and other fixtures and that total stack height is acceptable. Also check that after the mounting adapter is attached to the robot (or other device) you will have access to the mounting screws for attaching the transducer.
- Machine the mounting adapter plate for attaching to your robot (or other device) (see *Figure 2.1*). Mounting adapter plate dimensions are shown with the transducer in *Section 4—Transducer Specifications*. **All user-supplied screws must be flush with the inside of the mounting adapter to ensure proper clearance for the electronics inside the transducer.**
- Attach the mounting adapter to the robot (or other device). Attach the transducer to the mounting adapter with the screws and dowel pin provided. Thread locker is recommended to prevent the screws from backing out due to vibration (e.g.; Loctite thread locker No. 222).

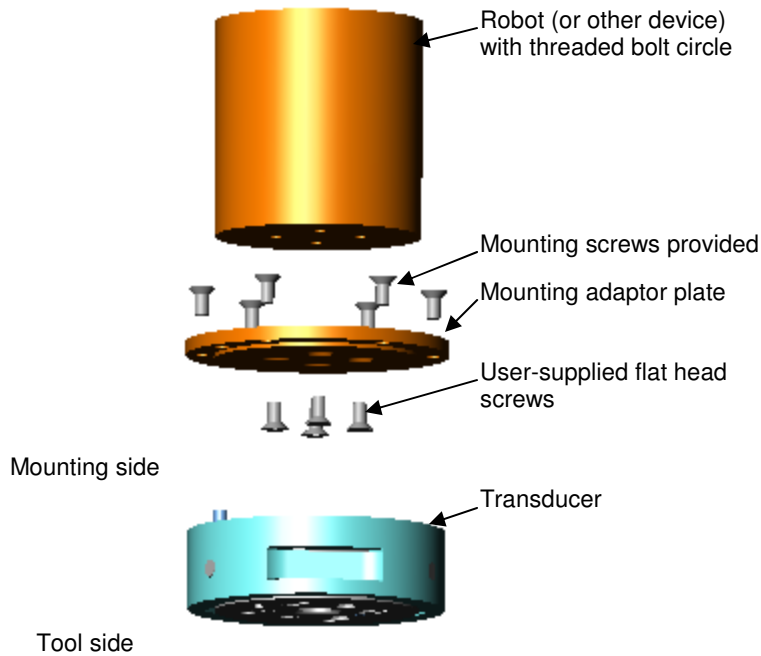

Figure 2.1—Attaching the transducer with the mounting adapter

2.4.5 Transducer Mounting Method II, Ring-plug Adapter

- Ensure that you provide sufficient clearances between the mounted transducer and other fixtures and that total stack height is acceptable. Also check that you will have room for tightening the mounting ring
- Machine the mounting plug for attaching to your robot (or other device). Mounting plug dimensions are shown with the transducer in *Section 4—Transducer Specifications* (see *Figure 2.2*).
- Attach the mounting plug. Then attach the transducer to the mounting plug using the attached mounting ring and flange.

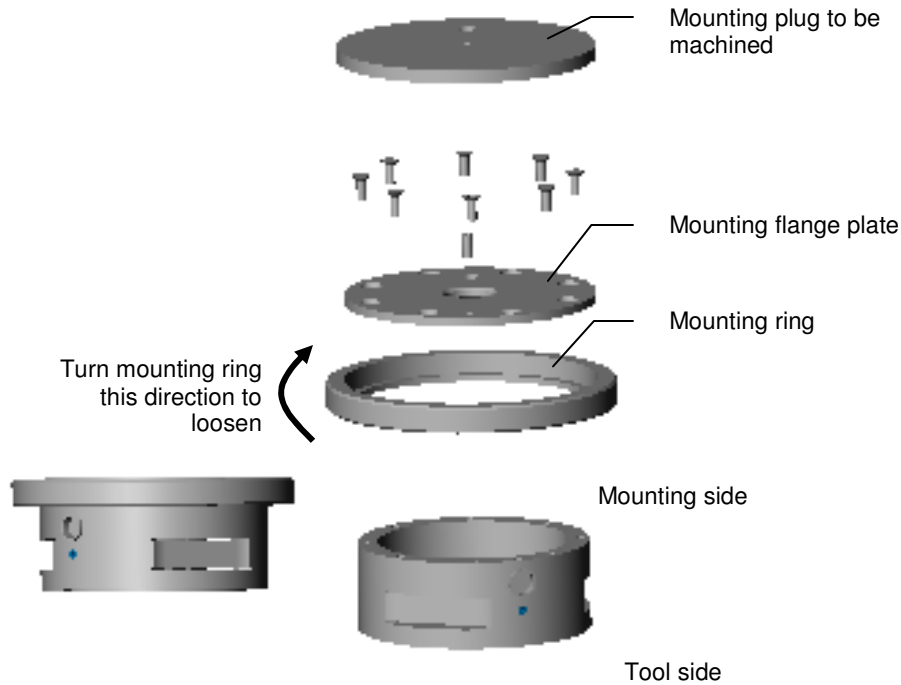

Figure 2.2—Using the mounting ring-plug adapter

Aside:

How the ring/plug adapter works: The flange plate is held to the transducer with screws and dowel pins. The plug mates to the flange plate with a center boss and a dowel pin. The plug also mates to the ring with matching threads. When the ring is turned, the plug screws into the ring causing the plug to clamp to the flange plate.

Aside:

If the ring cannot be removed by hand, use a strap wrench to loosen it. A strap wrench can be purchased through a supply company such as McMaster-Carr (PN-5378A1).

2.4.6 Transducer Mounting Method III, User-designed Interface

The transducer can be mounted using the bolt pattern provided. See *Section 4—Transducer Specifications*.

 **CAUTION:** Do not attempt to drill, tap, machine, or otherwise modify or disassemble the transducer. This could damage the transducer and will void the warranty. Some transducers have removable plates that may be modified if removed. See drawings in *Section 4—Transducer Specifications* for details.

Aside:
Examine the cable routing (Section 2) before modifying the mounting adapter plates. The F/T System's default point-of-origin is at the center of the mounting adapter surface. See *Section 4—Transducer Specifications* for drawings showing the default point-of-origin.

2.5 Mounting Your Tool

There are two methods for mounting your tool to most F/T transducers. Method II is only available on the Gamma and Delta transducers. The two methods are described below.

2.5.1 Tool Mounting Method I, Standard Tool Adapter

The tool adapter is factory-installed and the bolt circle is shown with the transducer in *Section 4—Transducer Specifications*. Most F/T tool adapters follow the ISO 9409-1 mounting pattern. Machine your tool interface plate to attach to this bolt circle.

2.5.2 Tool Mounting Method II, Optional Tool Ring-plug Adapter

- This method is similar to the optional mounting ring-plug adapter. See *Section 2.4.5—Transducer Mounting Method II, Mounting Ring-plug Adapter* for details.
- Ensure that you provide sufficient clearances between the mounted transducer and other fixtures and that total stack height is acceptable. Also ensure that you will have room for tightening the tool ring
- Machine the tool plug for mounting to the end-effector. The dimensions of the tool plug are shown in *Figure 2.3*.
- Mount the tool plug to your tool. Then mount the transducer to the tool plug using the attached tool ring and tool flange. See the *Aside* notes in *Section 2.4.5* for how the ring-plug adapter works. The tool flange is not attached to the standard tool adapter, but replaces it.

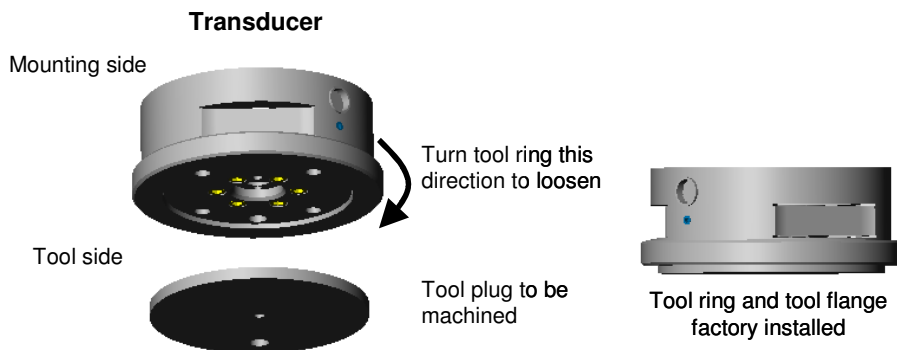



Figure 2.3—Using the tool ring-plug adapter

 **CAUTION:** Your tool may only touch the tool adapter plate. If your tool touches any other part of the transducer it will not properly sense loads.

3. Topics

3.1 Accuracy over Temperature

Typical gain errors introduced over temperature for F/T transducers with hardware temperature compensation are listed below. These changes in sensitivity are independent of the transducer’s rated accuracy at room temperature; the two accuracy ratings must be added to find an overall estimated accuracy at a certain temperature. This overall accuracy assumes that the unloaded and loaded measurements were taken at the same temperature. Drift error over temperature is not compensated and varies with each transducer. For best results, a reference reading should be taken or bias function executed at the current temperature before applying the load of interest.

Deviation from 22°C	Typical Gain Error
± 5°C	0.1%
± 15°C	0.5%
± 25°C	1%
± 50°C	5%

Table 3.1—Error Introduced Over Temperature for Non-Gamma Transducers

Deviation from 22°C	Typical Gain Error
± 5°C	0.1%
± 15°C	0.5%
± 25°C	1.5%
± 50°C	7%

Table 3.2—Error Introduced Over Temperature for Gamma Transducers

3.2 Tool Transformation Effects

All transducer working specifications pertain to the factory point-of-origin only. This includes the transducer’s range, resolution, and accuracy. The transducer working specifications at a customer-applied point-of-origin will differ from those at the factory point-of-origin.

3.3 Environmental

The F/T system is designed to be used in standard laboratory or light-manufacturing conditions. Transducers with an IP60 designation are able to withstand dusty environments, those with an IP65 designation are able to withstand dusty environments and wash down, and those with an IP68 designation are able to withstand dusty environments and fresh-water immersion to a specified depth. Transducers without IP65 or IP68 designation may be used in environments with up to 95% relative humidity, non-condensing.

Transducer Model Series	Storage	Operation	Units
9105-TIF Transducer	-5 to +75	0 to +60	°C
9105-TW Transducer	-5 to +105	-5 to +105	°C
9105-T Transducer	-5 to +105	0 to +70	°C
9105-NET Transducer	-65 to +150	0 to 70	°C

Note: These temperature ranges specify the storage and operation ranges in which the transducer can survive without damage. They do not take accuracy into account.

Table 3.3—Transducer Temperature Ranges

3.4 Mux Transducer Input Filter Frequency Response

Note: Mux transducers are only used in 9105-CTL, 9105-CON, and 9105-CTE systems.

The input filter used in 9105-T transducers and in the Mux box is used to prevent aliasing. This filtering is not used in 9105-TIF (DAQ) or our TWE transducers.

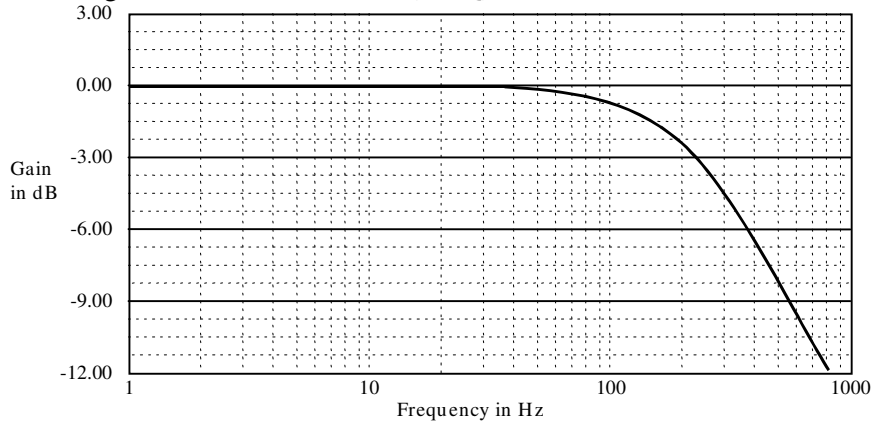

Figure 3.1—Mux input filter frequency response (-3dB @ 235Hz)

3.5 Transducer Strain Gage Saturation

The F/T sensor's strain gages are optimally placed to share information between the forces and torques applied to the sensor. Because of this sharing, it is possible to saturate the transducer with a complex load that has components below the rated load of the sensor. However, this arrangement allows a greater sensing range and resolution.



CAUTION: When any strain gage is saturated or otherwise inoperable, **all transducer F/T readings are invalid.** Therefore, it is vitally important to monitor for these conditions.

4. Transducer Specifications

4.1 Notes

4.1.1 About CTL Calibration Specifications

CTL refers to F/T systems that use the F/T Controller. Transducers used in these systems either have a 9105-T-x model transducer or include a Mux Box. The output resolution of CTL systems is different from other systems. CTL systems also provide analog voltage outputs that represent each of the six axes. CTL transducers have their own calibration specification listings because of these differences.

4.1.2 Complex Loading Graph Description

The graphs in the sections for each transducer may be used to estimate a sensor's range under complex loading. Each page represents one sensor body with either English or Metric units. The top graph represents combinations of forces in the X and/or Y directions with torques about the Z-axis. The bottom graph represents combinations of Z-axis forces with X- and/or Y-axis torques. The graphs contain several different calibrations, distinguished by line weight.

The sample graph shown in Figure 3.2 shows how operating ranges can change with complex loading. The labels indicate the following regions:

- A. Normal operating region. You can expect to achieve rated accuracy in this region.
- B. Saturation region. Any load in this region will report a gage saturation condition.
- C. Extended operating region. In this region, the sensor will operate correctly, but the full-scale accuracy is not guaranteed.

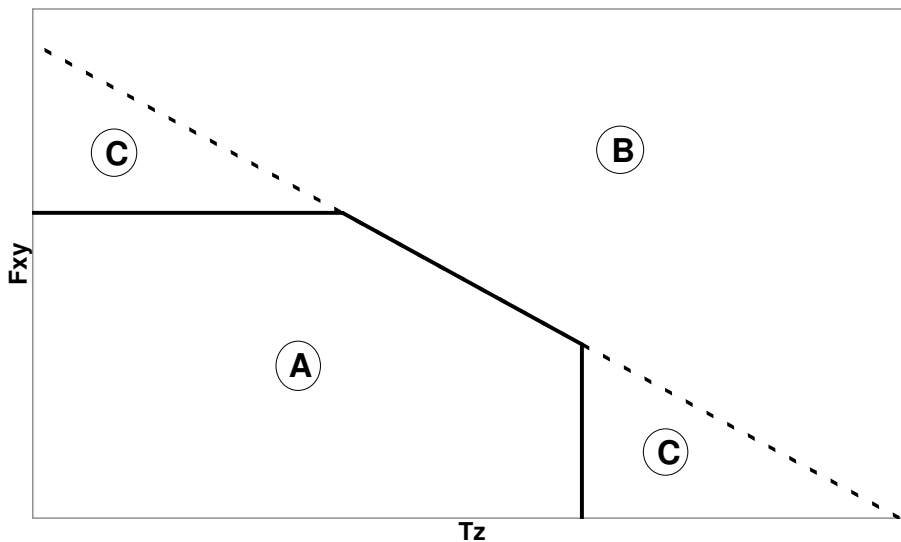

Figure 4.1—Complex loading sample graph

4.2 Nano17 Titanium

4.2.1 Calibration Specifications (excludes CTL calibrations)

US (English)

Calibration	Fx,Fy	Fz	Tx,Ty	Tz	Fx,Fy	Fz	Tx,Ty	Tz
US-1.8–0.4	1.8 lbf	3.15 lbf	0.4 lbf-in	0.4 lbf-in	1/3028 lbf	1/1721 lbf	1/13743 lbf-in	1/10430 lbf-in
US-3.6–0.8	3.6 lbf	6.3 lbf	0.8 lbf-in	0.8 lbf-in	1/1514 lbf	2/1721 lbf	2/13743 lbf-in	1/5215 lbf-in
US-7.2–1.6	7.2 lbf	12.6 lbf	1.6 lbf-in	1.6 lbf-in	1/757 lbf	5/2151 lbf	10/34357 lbf-in	2/5215 lbf-in
SENSING RANGES				RESOLUTION				

SI (Metric)

Calibration	Fx,Fy	Fz	Tx,Ty	Tz	Fx,Fy	Fz	Tx,Ty	Tz
SI-8–0.05	8 N	14.1 N	50 Nmm	50 Nmm	1/681 N	1/387 N	462/60815 Nmm	127/23078 Nmm
SI-16–0.1	16 N	28.2 N	100 Nmm	100 Nmm	2/681 N	2/387 N	924/60815 Nmm	127/11539 Nmm
SI-32–0.2	32 N	56.4 N	200 Nmm	200 Nmm	5/851 N	10/967 N	1848/60815 Nmm	254/11539 Nmm
SENSING RANGES				RESOLUTION				

These system resolutions quoted are the effective resolution after dropping eight counts of noise. The effective resolution can be improved with filtering. NOTE: Applied loads must be within range in each of the six axes for the F/T sensor to measure correctly.

4.2.2 CTL Calibration Specifications

US (English)

Calibration	Fx,Fy	Fz	Tx,Ty	Tz	Fx,Fy	Fz	Tx,Ty	Tz
US-1.8–0.4	1.8 lbf	3.15 lbf	0.4 lbf-in	0.4 lbf-in	1/1514 lbf	2/1721 lbf	2/13743 lbf-in	1/5215 lbf-in
US-3.6–0.8	3.6 lbf	6.3 lbf	0.8 lbf-in	0.8 lbf-in	1/757 lbf	5/2151 lbf	10/34357 lbf-in	2/5215 lbf-in
US-7.2–1.6	7.2 lbf	12.6 lbf	1.6 lbf-in	1.6 lbf-in	2/757 lbf	10/2151 lbf	5/8589 lbf-in	10/13037 lbf-in

SI (Metric)

SI-8–0.05	8 N	14.1 N	50 Nmm	50 Nmm	2/681 N	2/387 N	924/60815 Nmm	127/11539 Nmm
SI-16–0.1	16 N	28.2 N	100 Nmm	100 Nmm	5/851 N	10/967 N	1848/60815 Nmm	254/11539 Nmm
SI-32–0.2	32 N	56.4 N	200 Nmm	200 Nmm	10/851 N	10/483 N	3080/50679 Nmm	508/11539 Nmm
	SENSING RANGES				RESOLUTION			

US (English)

Calibration	Fx,Fy	Fz†	Tx,Ty, Tz	Fx,Fy	Fz†	Tx,Ty, Tz
US-1.8–0.4	±3 lbf	±4.25 lbf	±1 lbf-in	0.3 lbf/V	0.425 lbf/V	0.1 lbf-in/V
US-3.6–0.8	±6 lbf	±8.5 lbf	±2 lbf-in	0.6 lbf/V	0.85 lbf/V	0.2 lbf-in/V
US-7.2–1.6	±1 lbf	±17 lbf	±4 lbf-in	1.2 lbf/V	1.7 lbf/V	0.4 lbf-in/V

SI (Metric)

US-1.8–0.4	±12 N	±17 N	±120 Nmm	1.2 N/V	1.7 N/V	12 Nmm/V
US-3.6–0.8	±25 N	±35 N	±250 Nmm	2.5 N/V	3.5 N/V	25 Nmm/V
US-7.2–1.6	±50 N	±70 N	±500 Nmm	5 N/V	7 N/V	50 Nmm/V
	Analog Output Range			Analog ±10V Sensitivity‡		

Counts Value

Calibration	Fx, Fy, Fz	Tx, Ty, Tz	Fx, Fy, Fz	Tx, Ty, Tz
US-1.8–0.4	5120 / lbf	32000 / lbf-in	1280 / N	256 / Nmm
US-3.6–0.8	2560 / lbf	16000 / lbf-in	640 / N	128 / Nmm
US-7.2–1.6	1280 / lbf	8000 / lbf-in	320 / N	64 / Nmm
Tool Transform Factor	0.0016 in/unit		0.05 mm/unit	
	Counts Value – US (English)		Counts Value – SI (Metric)	

CTL resolutions are typical. System resolutions quoted are the effective resolution after dropping eight counts of noise. The effective resolution can be improved with filtering. NOTE: Applied loads must be within range in each of the six axes for the F/T sensor to measure correctly.

‡ ±5V Sensitivity values are double the listed ±10V Sensitivity values.

4.2.3 Nano17 Titanium Physical Properties

US (English)

Single-Axis Overload	
Fxy	±35 lbf
Fz	±70 lbf
Txy	±9 lbf-in
Tz	±10 lbf-in
Stiffness (Calculated)	
X-axis & Y-axis forces (Kx, Ky)	2.7x10 ⁴ lb/in
Z-axis force (Kz)	3.8x10 ⁴ lb/in
X-axis & Y-axis torque (Ktx, Kty)	1.2x10 ³ lbf-in/rad
Z-axis torque (Ktz)	2.0x10 ³ lbf-in/rad
Resonant Frequency (Measured)	
Fx, Fy, Tz	3000 Hz
Fz, Tx, Ty	3000 Hz
Physical Specifications	
Weight*	0.022 lb
Diameter*	0.67 in
Height*	0.57 in

SI (Metric)

Single-Axis Overload	
Fxy	±160 N
Fz	±310 N
Txy	±1 Nm
Tz	±1.1 Nm
Stiffness (Calculated)	
X-axis & Y-axis forces (Kx, Ky)	4.8x10 ⁶ N/m
Z-axis force (Kz)	6.6x10 ⁶ N/m
X-axis & Y-axis torque (Ktx, Kty)	1.4x10 ² Nm/rad
Z-axis torque (Ktz)	2.2x10 ² Nm/rad
Resonant Frequency (Measured)	
Fx, Fy, Tz	3000 Hz
Fz, Tx, Ty	3000 Hz
Physical Specifications	
Weight*	0.00998 kg
Diameter*	17 mm
Height*	15 mm

* Specifications include standard interface plate.

4.2.4 Nano17 Titanium (US Calibration Complex Loading)

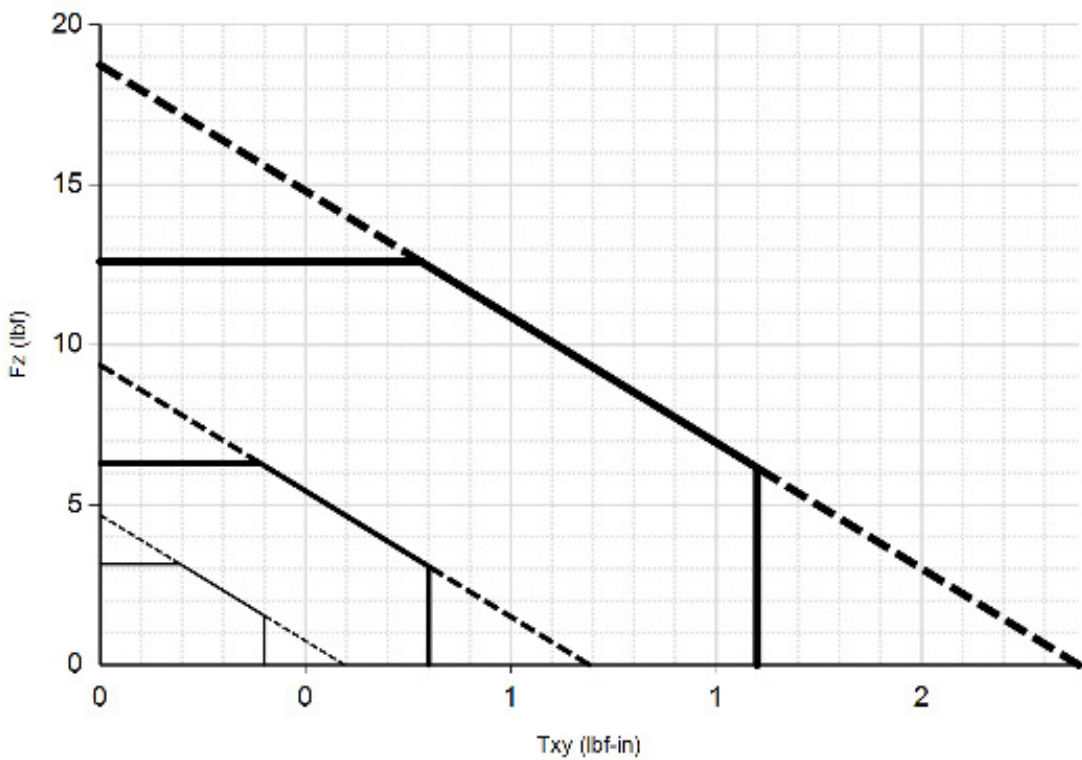
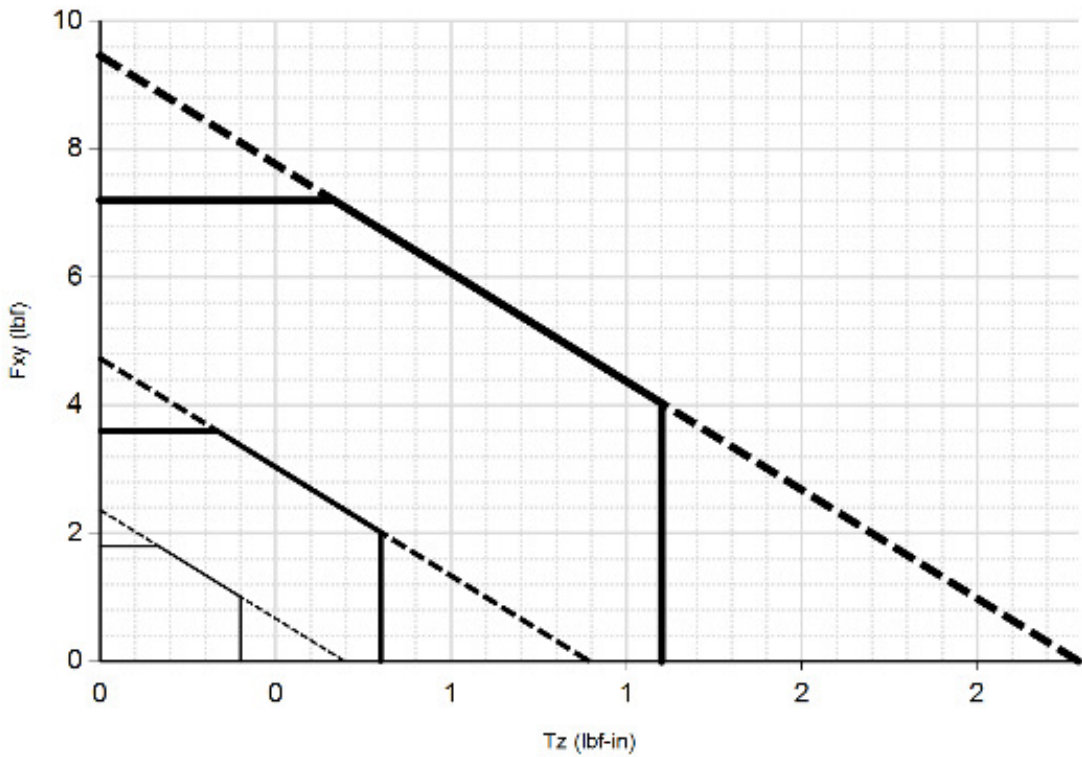

US-1.8-0.4
 US-3.6-0.8
 US-7.2-1.6

4.2.5 Nano17 Titanium (SI Calibration Complex Loading)

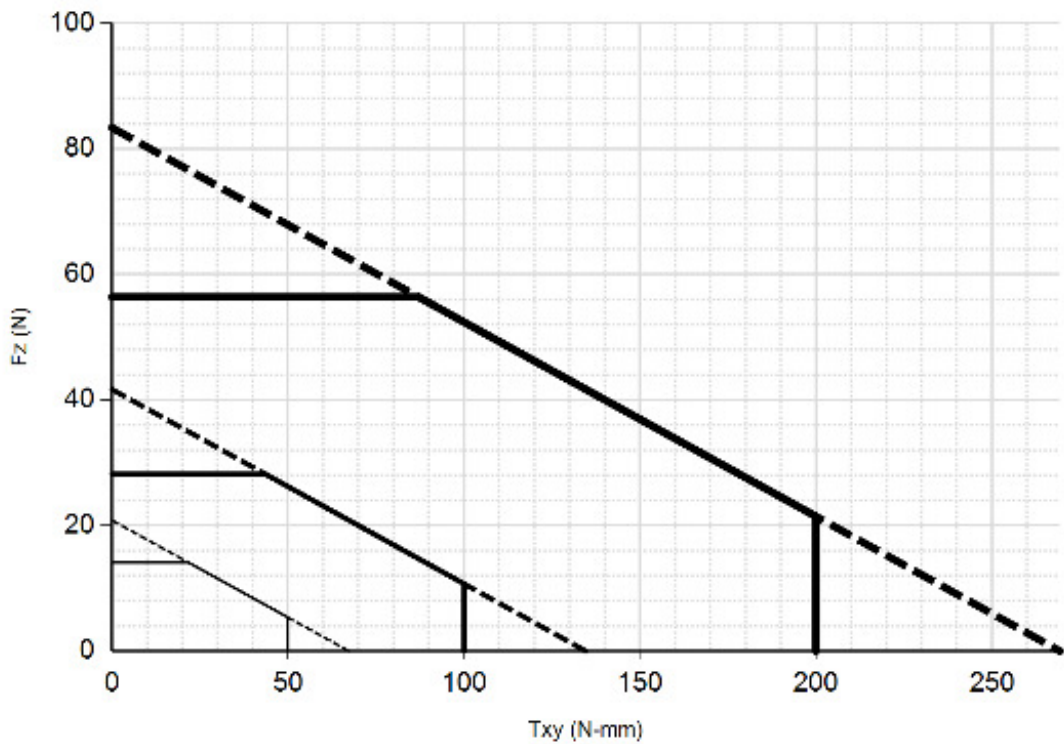
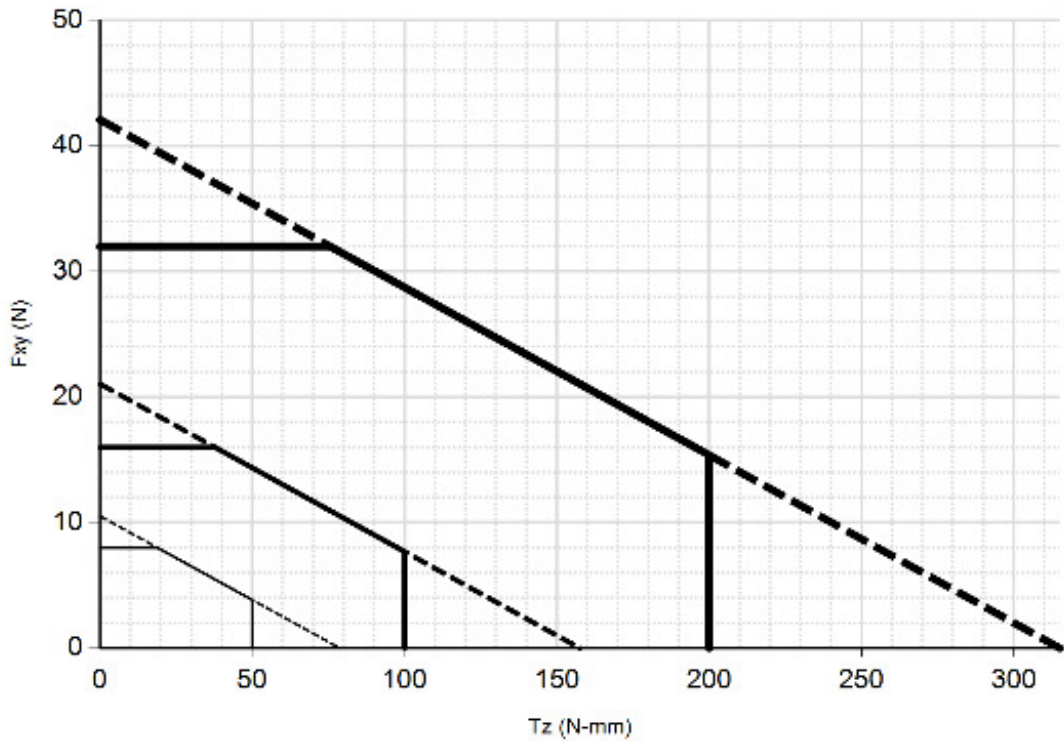

SI-8-0.05
 SI-16-0.1
 SI-32-0.2

4.2.6 Nano17 Titanium Transducer Drawing

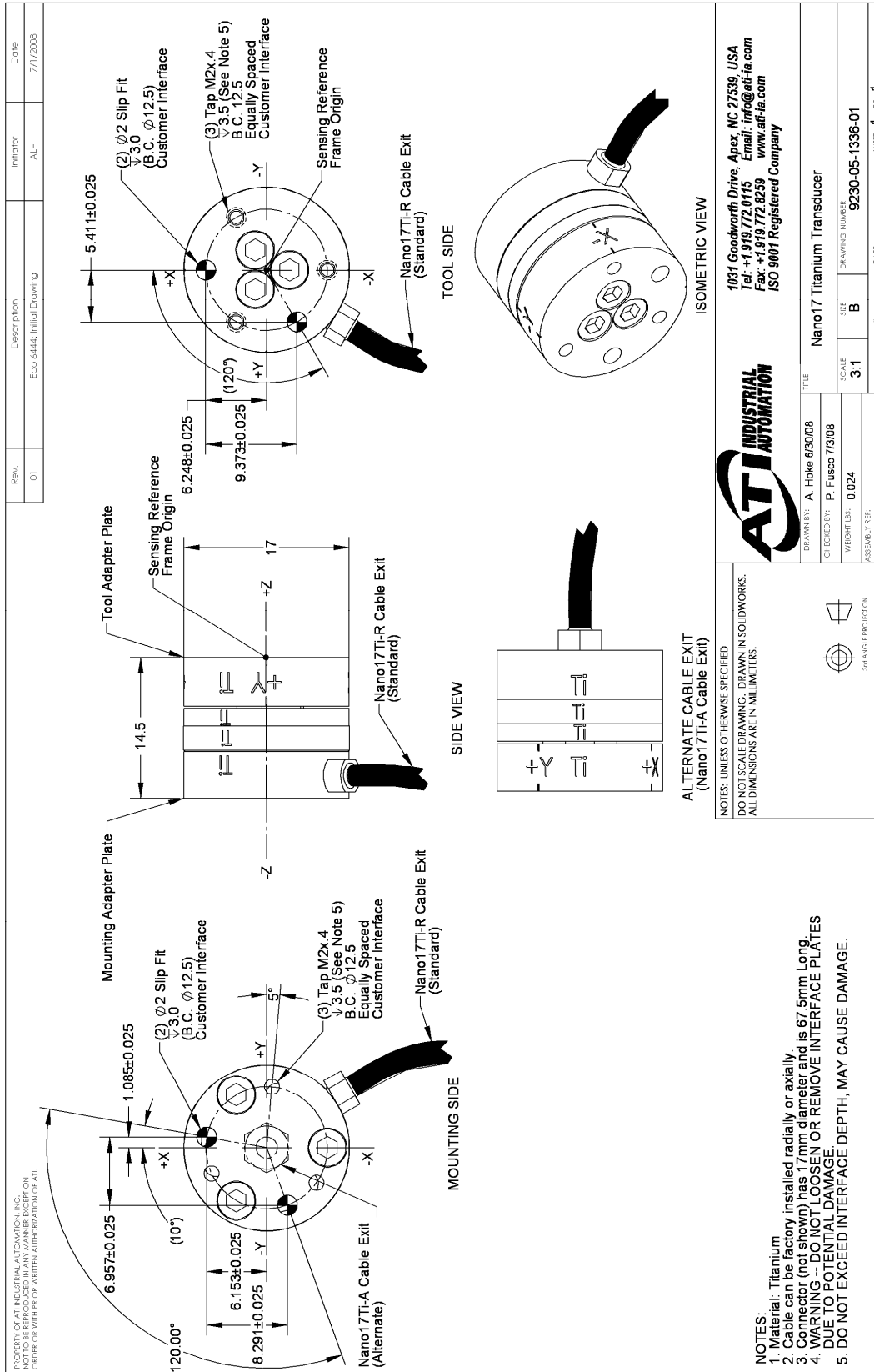

PROPERTY OF ATI INDUSTRIAL AUTOMATION, INC.
 NOT TO BE REPRODUCED IN ANY MANNER EXCEPT ON
 ORDER OR WITH PRIOR WRITTEN AUTHORIZATION OF ATI.

1031 Goodworth Drive, Apex, NC 27539, USA
 Tel: +1 919.772.0115 Email: info@ati-ia.com
 Fax: +1 919.772.8259 www.ati-ia.com
 ISO 9001 Registered Company



DRAWN BY:	A. Hoke 6/30/08	TITLE	Nano17 Titanium Transducer
CHECKED BY:	P. Fusco 7/3/08	SCALE	3:1
WEIGHT LBS:	0.024	SIZE	B
ASSEMBLY REF:		DRAWING NUMBER	9230-05-1336-01
		PRODUCT RELEASE #	
		DATE:	SHEET 1 OF 1

NOTES: UNLESS OTHERWISE SPECIFIED
 DO NOT SCALE DRAWING. DRAWN IN SOLIDWORKS.
 ALL DIMENSIONS ARE IN MILLIMETERS.



- NOTES:
1. Material: Titanium
 2. Cable can be factory installed radially or axially.
 3. Connector (not shown) has 17mm diameter and is 67.5mm Long.
 4. WARNING -- DO NOT LOOSEN OR REMOVE INTERFACE PLATES DUE TO POTENTIAL DAMAGE.
 5. DO NOT EXCEED INTERFACE DEPTH, MAY CAUSE DAMAGE.

4.3 Nano17 (Includes IP65/IP68 Versions)

4.3.1 Calibration Specifications (excludes CTL calibrations)

US (English)

Calibration	Fx,Fy	Fz	Tx,Ty	Tz	Fx,Fy	Fz	Tx,Ty	Tz
US-3-1	3 lbf	4.25 lbf	1 lbf-in	1 lbf-in	1/1280 lbf	1/1280 lbf	1/8000 lbf-in	1/8000 lbf-in
US-6-2	6 lbf	8.5 lbf	2 lbf-in	2 lbf-in	1/640 lbf	1/640 lbf	1/4000 lbf-in	1/4000 lbf-in
US-12-4	12 lbf	17 lbf	4 lbf-in	4 lbf-in	1/320 lbf	1/320 lbf	1/2000 lbf-in	1/2000 lbf-in
	SENSING RANGES				RESOLUTION			

SI (Metric)

Calibration	Fx,Fy	Fz	Tx,Ty	Tz	Fx,Fy	Fz	Tx,Ty	Tz
SI-12-0.12	12 N	17 N	120 Nmm	120 Nmm	1/320 N	1/320 N	1/64 Nmm	1/64 Nmm
SI-25-0.25	25 N	35 N	250 Nmm	250 Nmm	1/160 N	1/160 N	1/32 Nmm	1/32 Nmm
SI-50-0.5	50 N	70 N	500 Nmm	500 Nmm	1/80 N	1/80 N	1/16 Nmm	1/16 Nmm
	SENSING RANGES				RESOLUTION			

These system resolutions quoted are the effective resolution after dropping eight counts of noise. The effective resolution can be improved with filtering. NOTE: Applied loads must be within range in each of the six axes for the F/T sensor to measure correctly.

4.3.2 CTL Calibration Specifications

US (English)

Calibration	Fx,Fy	Fz	Tx,Ty	Tz	Fx,Fy	Fz	Tx,Ty	Tz
US-3-1	3 lbf	4.25 lbf	1 lbf-in	1 lbf-in	1/640 lbf	1/640 lbf	1/4000 lbf-in	1/4000 lbf-in
US-6-2	6 lbf	8.5 lbf	2 lbf-in	2 lbf-in	1/320 lbf	1/320 lbf	1/2000 lbf-in	1/2000 lbf-in
US-12-4	12 lbf	17 lbf	4 lbf-in	4 lbf-in	1/160 lbf	1/160 lbf	1/1000 lbf-in	1/1000 lbf-in
SENSING RANGES				RESOLUTION				

SI (Metric)

Calibration	Fx,Fy	Fz	Tx,Ty	Tz	Fx,Fy	Fz	Tx,Ty	Tz
SI-12-0.12	12 N	17 N	120 Nm	120 Nmm	1/160 N	1/160 N	1/32 Nmm	1/32 Nmm
SI-25-0.25	25 N	35 N	250 Nmm	250 Nmm	1/80 N	1/80 N	1/16 Nmm	1/16 Nmm
SI-50-0.5	50 N	70 N	500 Nmm	500 Nmm	1/40 N	1/40 N	1/8 Nmm	1/8 Nmm
SENSING RANGES				RESOLUTION				

US (English)

Calibration	Fx,Fy	Fz	Tx,Ty, Tz	Fx,Fy	Fz	Tx,Ty, Tz
US-3-1	±3 lbf	±4.25 lbf	±1 lbf-in	0.3 lbf/V	0.425 lbf/V	0.1 lbf-in/V
US-6-2	±6 lbf	±8.5 lbf	±2 lbf-in	0.6 lbf/V	0.85 lbf/V	0.2 lbf-in/V
US-12-4	±12 lbf	±17 lbf	±4 lbf-in	1.2 lbf/V	1.7 lbf/V	0.4 lbf-in/V
Analog Output Range			Analog ±10V Sensitivity‡			

SI (Metric)

Calibration	Fx,Fy	Fz	Tx,Ty, Tz	Fx,Fy	Fz	Tx,Ty, Tz
SI-12-0.25	±12 N	±17 N	±120 Nmm	1.2 N/V	1.7 N/V	12 Nmm/V
SI-25-0.25	±25 N	±35 N	±250 Nmm	2.5 N/V	3.5 N/V	25 Nmm/V
SI-50-0.5	±50 N	±70 N	±500 Nmm	5 N/V	7 N/V	50 Nmm/V
Analog Output Range			Analog ±10V Sensitivity‡			

Counts Value

Calibration	Fx, Fy, Fz	Tx, Ty, Tz	Fx, Fy, Fz	Tx, Ty, Tz
US-3-1	5120 / lbf	32000 / lbf-in	1280 / N	256 / Nmm
US-6-2	2560 / lbf	16000 / lbf-in	640 / N	128 / Nmm
US-12-4	1280 / lbf	8000 / lbf-in	320 / N	64 / Nmm
Tool Transform Factor	0.0016 in/unit		0.05 mm/unit	
Counts Value – US (English)			Counts Value – SI (Metric)	

CTL resolutions are typical. System resolutions quoted are the effective resolution after dropping eight counts of noise. The effective resolution can be improved with filtering. NOTE: Applied loads must be within range in each of the six axes for the F/T sensor to measure correctly.

‡ ±5V Sensitivity values are double the listed ±10V Sensitivity values.



CAUTION:

IP68 Nano17 Fz as a Function of Submersion Depth:

When submerged, IP68 transducers exhibit a decrease in Fz range related to the submersion depth. This loss is the result of pressure-induced preloading on the transducer. The preload can be masked by biasing the transducer at the depth prior to applying the load to be measured. The following estimates are for room temperature fresh water at seal level.

IP68 Nano17	US	Metric
Fz preload at 1m depth	-0.50 lb	-2.22 N
Fz preload at other depths	-0.15 lb/ft × depthInFeet	-2.22 N/m × depthInMeters

4.3.3 Nano17 Physical Properties US (English)

Single-Axis Overload	
Fxy	±56 lbf
Fz	±110 lbf
Txy	±14 lbf-in
Tz	±16 lbf-in
Stiffness (Calculated)	
X-axis & Y-axis forces (Kx, Ky)	4.7x10 ⁴ lb/in
Z-axis force (Kz)	6.5x10 ⁴ lb/in
X-axis & Y-axis torque (Ktx, Kty)	2.1x10 ³ lbf-in/rad
Z-axis torque (Ktz)	3.4x10 ³ lbf-in/rad
Resonant Frequency (Measured)	
Fx, Fy, Tz	7200 Hz
Fz, Tx, Ty	7200 Hz
Physical Specifications	
Weight*	0.02 lb
Diameter*	0.67 in
Height*	0.57 in

SI (Metric)

Single-Axis Overload	
Fxy	±250 N
Fz	±480 N
Txy	±1.6 Nm
Tz	±1.8 Nm
Stiffness (Calculated)	
X-axis & Y-axis forces (Kx, Ky)	8.2x10 ⁶ N/m
Z-axis force (Kz)	1.1x10 ⁷ N/m
X-axis & Y-axis torque (Ktx, Kty)	2.4x10 ² Nm/rad
Z-axis torque (Ktz)	3.8x10 ² Nm/rad
Resonant Frequency (Measured)	
Fx, Fy, Tz	7200 Hz
Fz, Tx, Ty	7200 Hz
Physical Specifications	
Weight*	0.00907 kg
Diameter*	17 mm
Height*	15 mm

* Specifications include standard interface plate.

4.3.4 Nano17 (US Calibration Complex Loading)

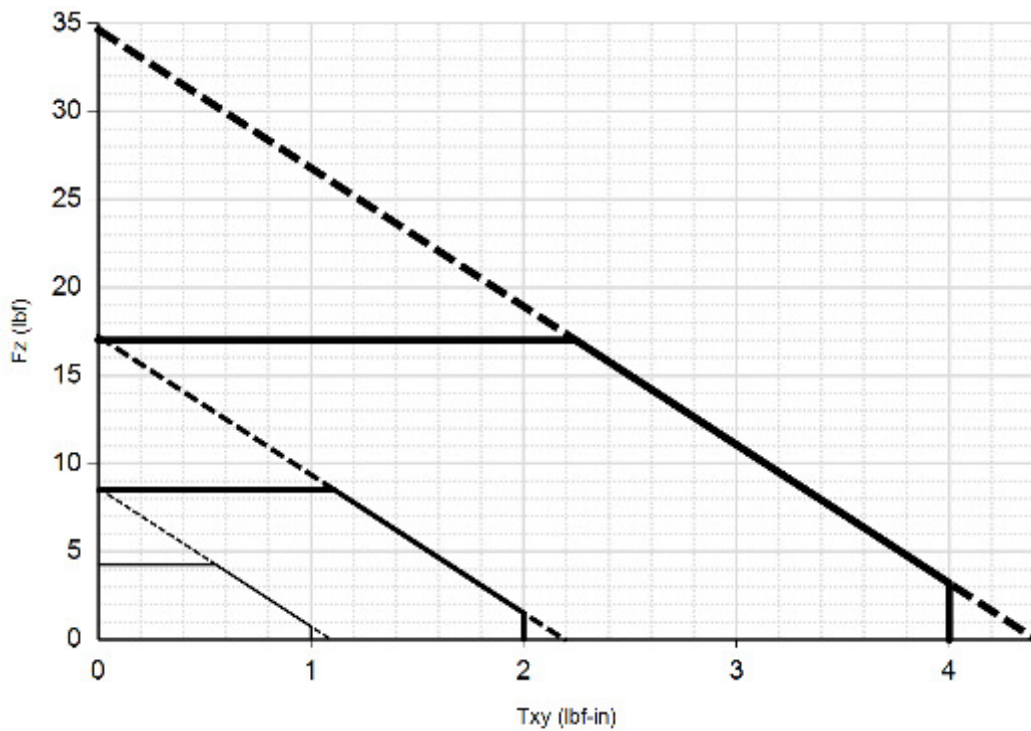
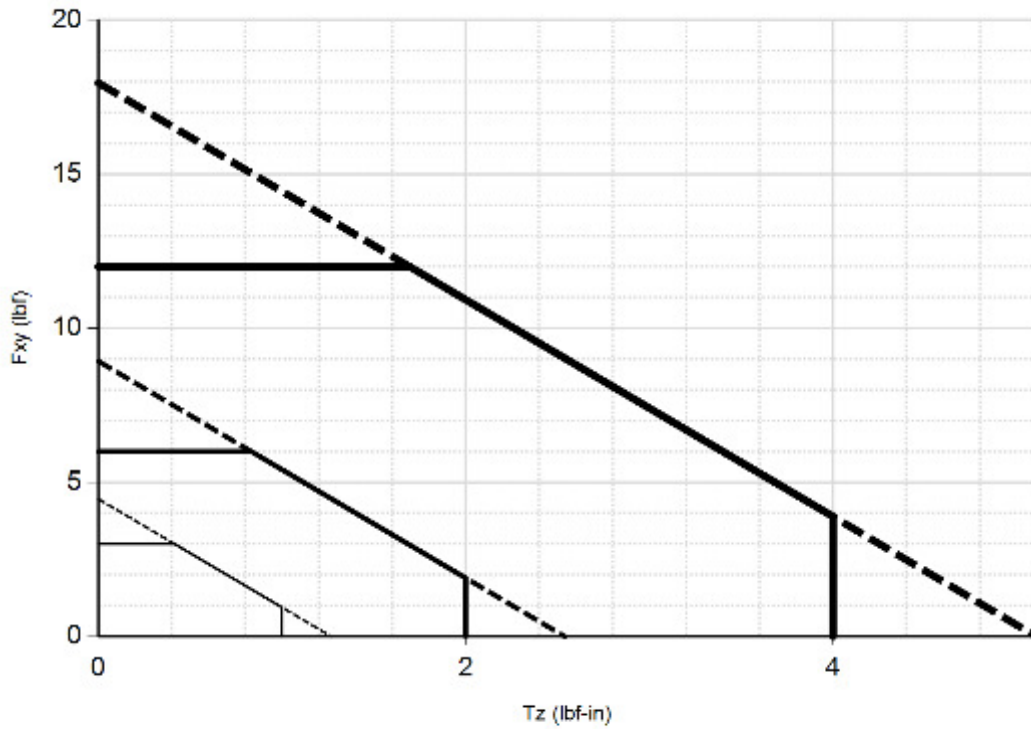

US-3-1
 US-6-2
 US-12-4

4.3.5 Nano17 (SI Calibration Complex Loading)

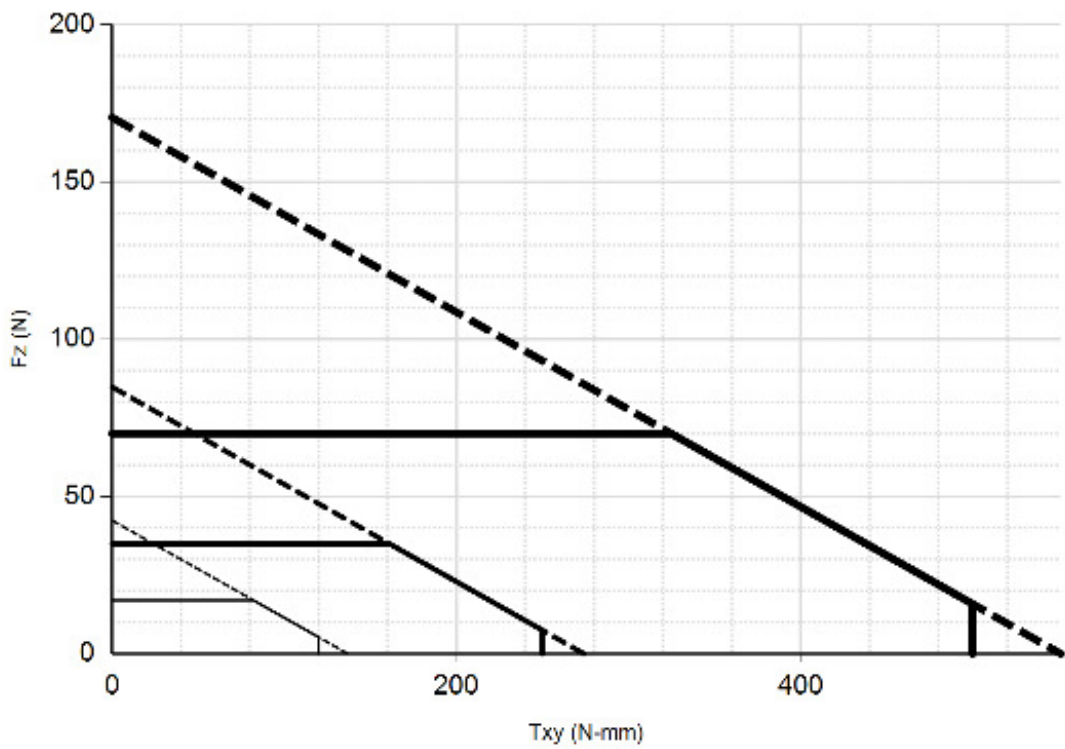
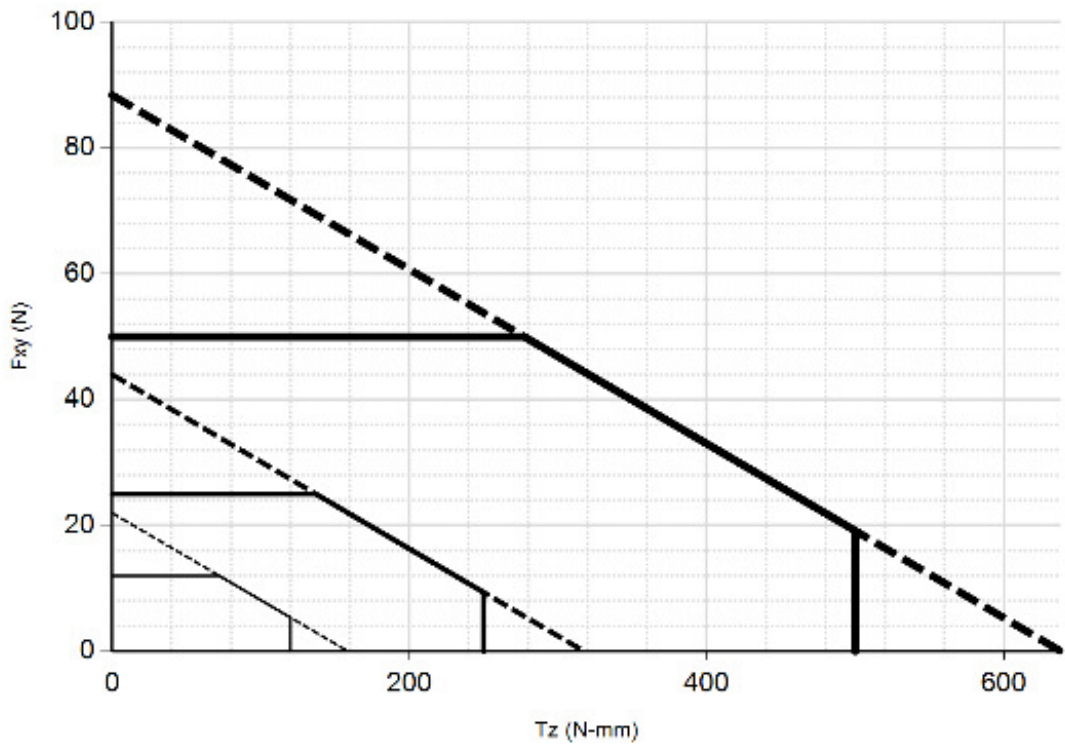

—— SI-12-0.12
—— SI-25-0.25
—— SI-50-0.5

4.3.6 Nano17-E Transducer

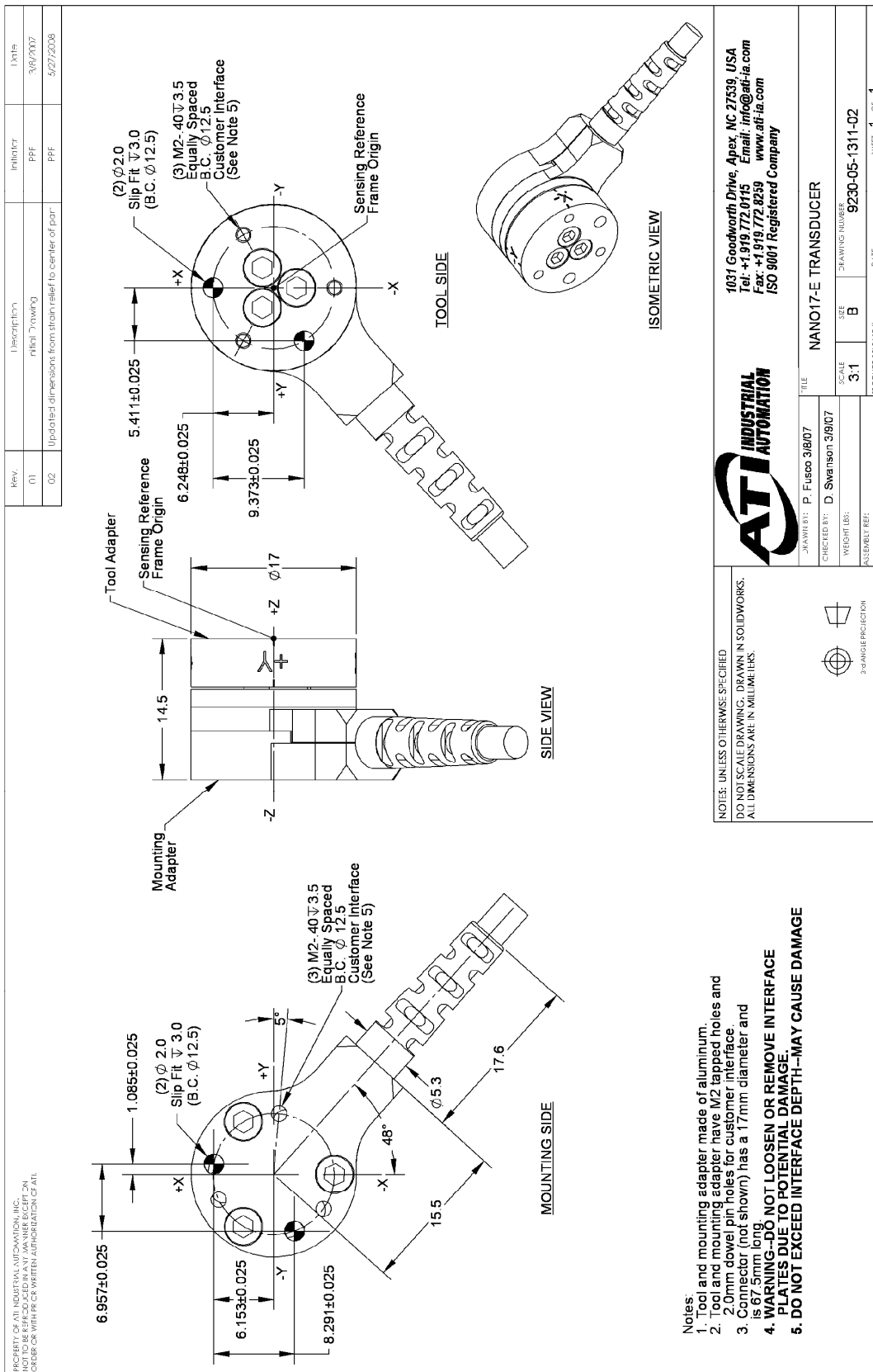

4.3.7 Nano17 IP65/IP68 Transducer with Axial Cable Exit

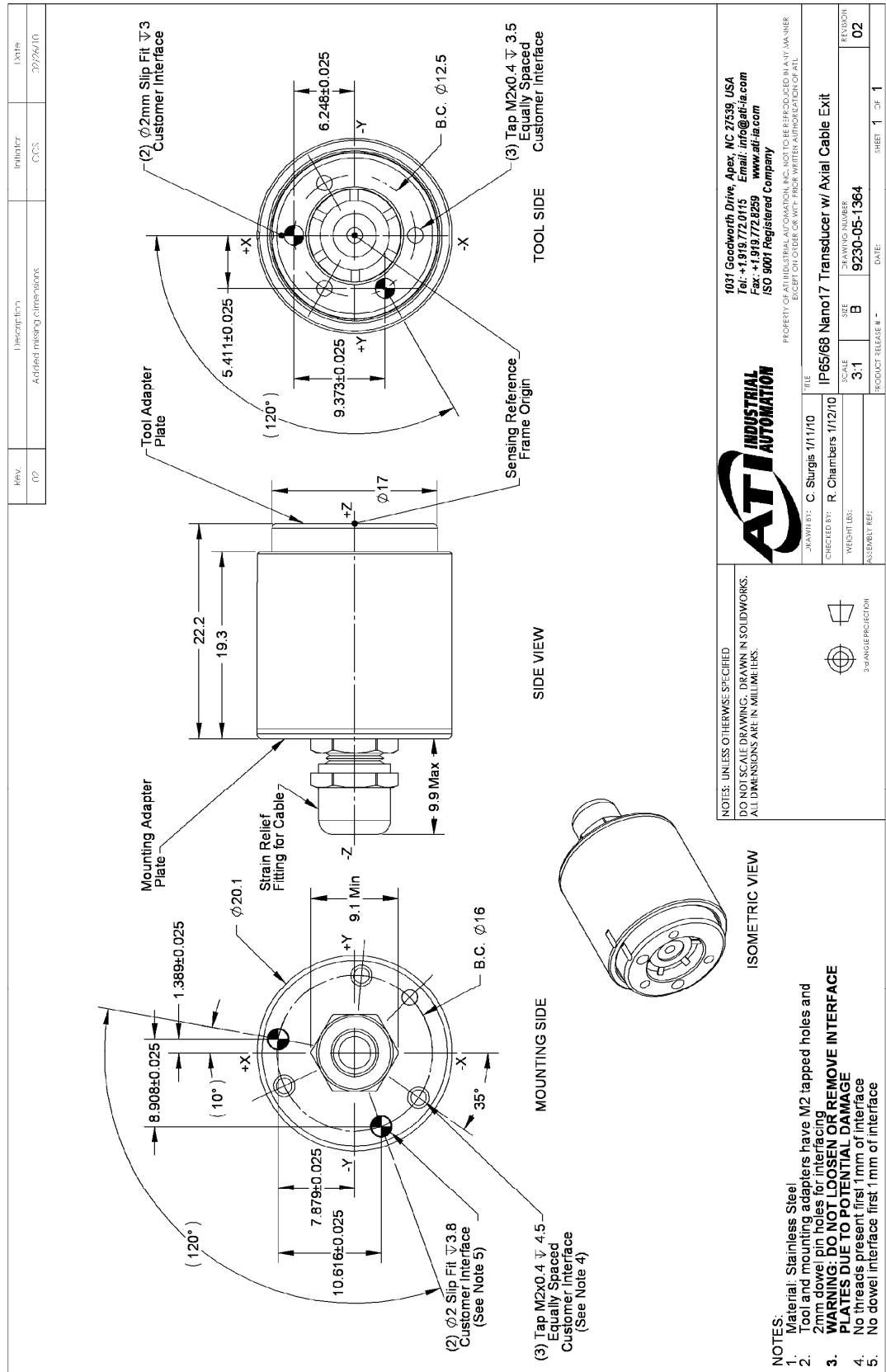

ATI INDUSTRIAL AUTOMATION

1031 Goodworth Drive, Apex, NC 27539 USA
 Tel: +1.919.772.0115 Email: info@ati-ia.com
 Fax: +1.919.772.8259 www.ati-ia.com
 ISO 9001 Registered Company

PROPERTY OF INDUSTRIAL AUTOMATION, INC. NOT TO BE REPRODUCED IN ANY MANNER EXCEPT OUTSIDE OR WITH WRITTEN AUTHORIZATION OF ATI.

DRAWN BY: C. Shurgis 1/11/10	TITLE: IP65/68 Nano17 Transducer w/ Axial Cable Exit	DRAWING NUMBER: 9230-05-1364	REVISION: 02
CHECKED BY: R. Chambers 1/12/10	SCALE: 3:1	DATE: 07/26/10	PRODUCT RELEASE # - 1
WEIGHT USE: B	ASSEMBLY REF:	SHEET 1 OF 1	

NOTES: UNLESS OTHERWISE SPECIFIED
 DO NOT SCALE DRAWING. DRAWN IN SOLIDWORKS.
 ALL DIMENSIONS ARE IN MILLIMETERS.

3 ANGLE PRECISION

4.3.8 Legacy Nano17 Transducer

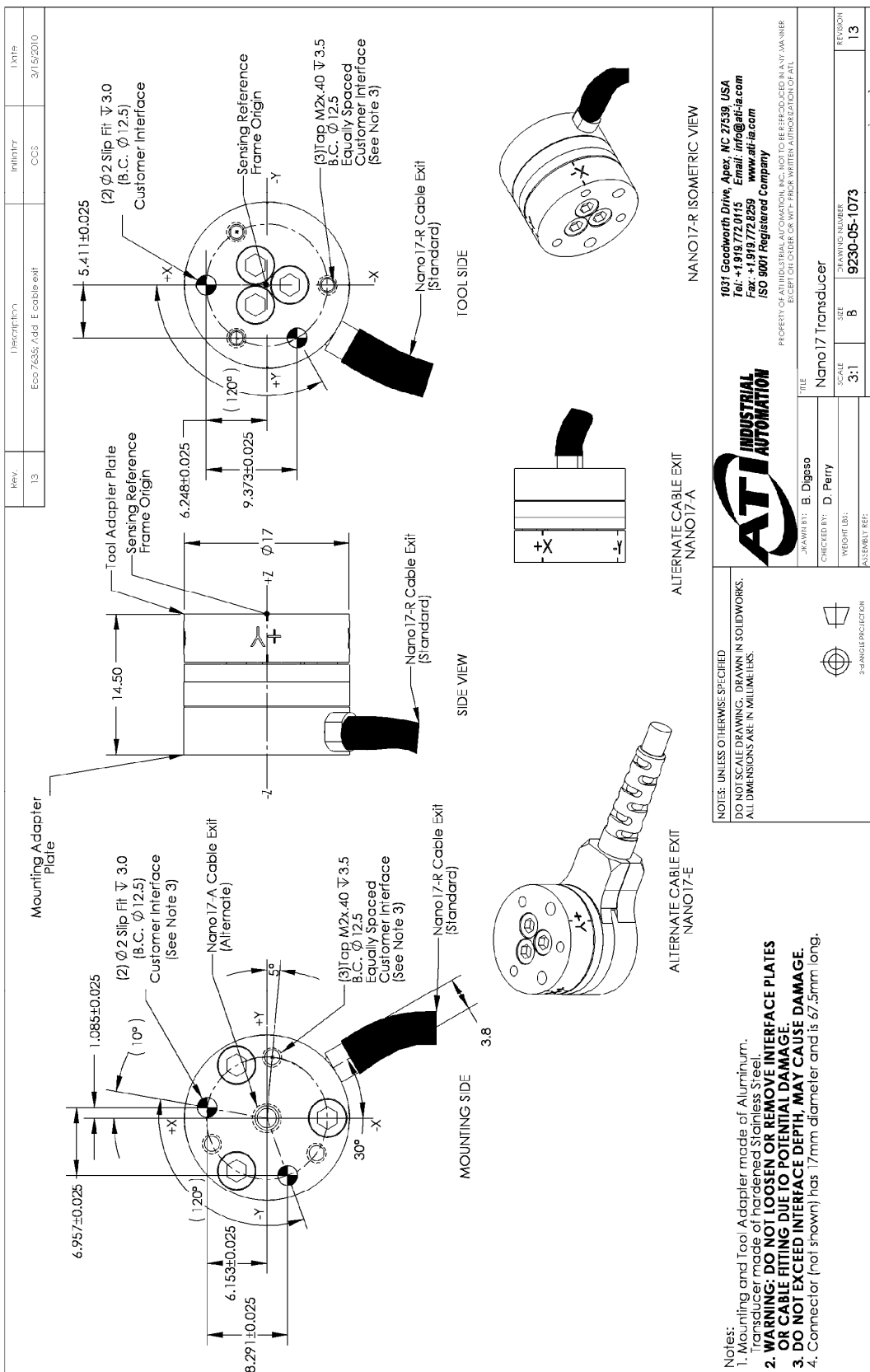

ATI INDUSTRIAL AUTOMATION	
1031 Goodworth Drive, Apex, NC 27539, USA Tel: +1.919.772.0115 Email: info@ati-ia.com Fax: +1.919.772.8259 www.ati-ia.com ISO 9001 Registered Company	
PROPERTY OF ATI INDUSTRIAL AUTOMATION. NO PARTS TO BE REPRODUCED IN ANY MANNER EXCEPT BY ORDER OR WITH PRIOR WRITTEN AUTHORIZATION OF ATI.	
TITLE	Nano17 Transducer
DRAWN BY:	B. Digoso
CHECKED BY:	D. Perry
SCALE	3:1
WEIGHT (LBS)	B
ASSEMBLY REF:	9230-05-1073
DRAWING NUMBER	9230-05-1073
REVISION	13

NOTES: UNLESS OTHERWISE SPECIFIED
 DO NOT SCALE DRAWING. DRAWN IN SOLIDWORKS.
 ALL DIMENSIONS ARE IN MILLIMETERS.

3 ANGLE PRECISION

PRODUCT RELEASE #	DATE	SHEET	OF
		21	21

4.4 Nano25—(Includes IP65/IP68 Versions)

4.4.1 Calibration Specifications (excludes CTL calibrations)

US (English)

Calibration	Fx,Fy	Fz	Tx,Ty	Tz	Fx,Fy	Fz	Tx,Ty	Tz
US-25-25	25 lbf	100 lbf	25 lbf-in	25 lbf-in	1/224 lbf	3/224 lbf	1/160 lbf-in	1/320 lbf-in
US-50-50	50 lbf	200 lbf	50 lbf-in	30 lbf-in	1/112 lbf	3/112 lbf	1/80 lbf-in	1/160 lbf-in
	SENSING RANGES				RESOLUTION			

SI (Metric)

Calibration	Fx,Fy	Fz	Tx,Ty	Tz	Fx,Fy	Fz	Tx,Ty	Tz
SI-125-3	125 N	500 N	3 Nm	3 Nm	1/48 N	1/16 N	1/1320 Nm	1/2640 Nm
SI-250-6	250 N	1000 N	6 Nm	3.4 Nm	1/24 N	1/8 N	1/660 Nm	1/1320 Nm
	SENSING RANGES				RESOLUTION			

These system resolutions quoted are the effective resolution after dropping four counts of noise. The effective resolution can be improved with filtering. NOTE: Applied loads must be within range in each of the six axes for the F/T sensor to measure correctly.

4.4.2 CTL Calibration Specifications

US (English)

Calibration	Fx,Fy	Fz	Tx,Ty	Tz	Fx,Fy	Fz	Tx,Ty	Tz
US-25-25	25 lbf	100 lbf	25 lbf-in	25 lbf-in	1/112 lbf	3/112 lbf	1/80 lbf-in	1/160 lbf-in
US-50-50	50 lbf	200 lbf	50 lbf-in	30 lbf-in	1/56 lbf	3/56 lbf	1/40 lbf-in	1/80 lbf-in
SENSING RANGES				RESOLUTION				

SI (Metric)

Calibration	Fx,Fy	Fz	Tx,Ty	Tz	Fx,Fy	Fz	Tx,Ty	Tz
SI-125-3	125 N	500 N	3 Nm	3 Nm	1/24 N	1/8 N	1/660 Nm	1/1320 Nm
SI-250-6	250 N	1000 N	6 Nm	3.4 Nm	1/12 N	1/4 N	1/330 Nm	1/660 Nm
SENSING RANGES				RESOLUTION				

US (English)

Calibration	Fx,Fy	Fz	Tx,Ty, Tz	Fx,Fy	Fz	Tx,Ty, Tz
US-25-25	±25 lbf	±100 lbf	±25 lbf-in	2.5 lbf/V	10 lbf/V	2.5 lbf-in/V
US-50-50	±50 lbf	±200 lbf	±50 lbf-in	5 lbf/V	20 lbf/V	5 lbf-in/V
Analog Output Range			Analog ±10V Sensitivity‡			

SI (Metric)

Calibration	Fx,Fy	Fz	Tx,Ty, Tz	Fx,Fy	Fz	Tx,Ty, Tz
SI-125-3	±125 N	±500 N	±3 Nm	12.5 N/V	50 N/V	0.3 Nm/V
SI-250-6	±250 N	1000 N	±6 Nm	25 N/V	100 N/V	0.6 Nm/V
Analog Output Range			Analog ±10V Sensitivity‡			

Counts Value

Calibration	Fx, Fy, Fz	Tx, Ty, Tz	Fx, Fy, Fz	Tx, Ty, Tz
US-25-25	896 / lbf	1280 / lbf-in	192 / N	10560 / N
US-50-50	448 / lbf	640 / lbf-in	96 / Nm	5280 / Nm
Tool Transform Factor	0.007 in/unit		0.18182 mm/unit	
Counts Value – US (English)			Counts Value – SI (Metric)	

Note: Applying moments beyond ±30 lbf-in (±3.4Nm) in Tz can cause hysteresis and permanent zero-point change in the Nano25 (applies to all versions of the Nano25).

CTL resolutions are typical. System resolutions quoted are the effective resolution after dropping eight counts of noise. The effective resolution can be improved with filtering. NOTE: Applied loads must be within range in each of the six axes for the F/T sensor to measure correctly.

† For IP68 version see caution on physical properties page.

‡ ±5V Sensitivity values are double the listed ±10V Sensitivity values.

**4.4.3 Nano25 Physical Properties (Includes IP65/IP68 Versions)
US (English)**

Single-Axis Overload	
Fxy	±520 lbf
Fz	±1600 lbf
Txy	±380 lbf-in
Tz	±560 lbf-in
Stiffness (Calculated)	
X-axis & Y-axis forces (Kx, Ky)	3.0×10^5 lb/in
Z-axis force (Kz)	6.3×10^5 lb/in
X-axis & Y-axis torque (Ktx, Kty)	5.7×10^4 lbf-in/rad
Z-axis torque (Ktz)	8.1×10^4 lbf-in/rad
Resonant Frequency (Measured)	
Fx, Fy, Tz	3600 Hz
Fz, Tx, Ty	3800 Hz
Physical Specifications	
Weight*	0.14 lb
Diameter*	0.98 in
Height*	0.85 in

SI (Metric)

Single-Axis Overload	
Fxy	±2300 N
Fz	±7300 N
Txy	±43 Nm
Tz	±63 Nm
Stiffness (Calculated)	
X-axis & Y-axis forces (Kx, Ky)	5.3×10^7 N/m
Z-axis force (Kz)	1.1×10^8 N/m
X-axis & Y-axis torque (Ktx, Kty)	6.5×10^3 Nm/rad
Z-axis torque (Ktz)	9.2×10^3 Nm/rad
Resonant Frequency (Measured)	
Fx, Fy, Tz	3600 Hz
Fz, Tx, Ty	3800 Hz
Physical Specifications	
Weight*	0.0635 kg
Diameter*	25 mm
Height*	22 mm

* Specifications include standard interface plates.



CAUTION:

IP68 Nano25 Fz as a Function of Submersion Depth:

When submerged, IP68 transducers exhibit a decrease in Fz range related to the submersion depth. This loss is the result of pressure-induced preloading on the transducer. The preload can be masked by biasing the transducer at the depth prior to applying the load to be measured. The following estimates are for room temperature fresh water at seal level.

IP68 Nano25	US	Metric
Fz preload at 4m depth	-4.33 lb	-19.26 N
Fz preload at other depths	-0.33 lb/ft × depthInFeet	-4.81 N/m × depthInMeters

**4.4.4 Nano25 (US Calibration Complex Loading)
 (Includes IP65/IP68 Versions)**

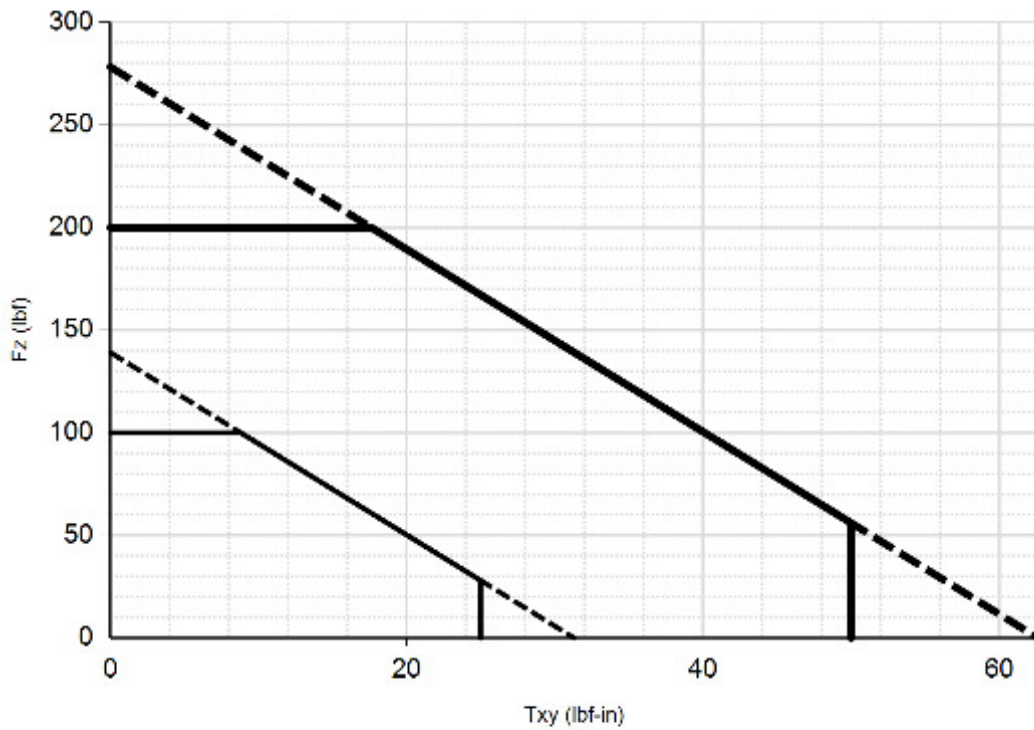
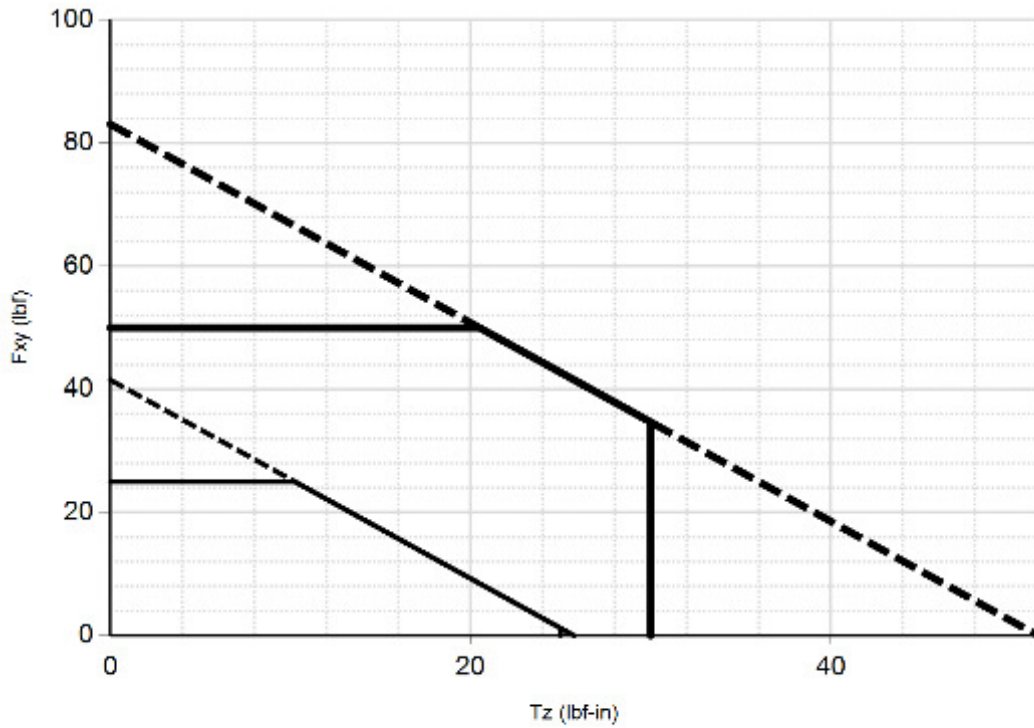

— US-25-25 — US-50-50

**4.4.5 Nano25 (SI Calibration Complex Loading)
 (Includes IP65/IP68 Versions)**

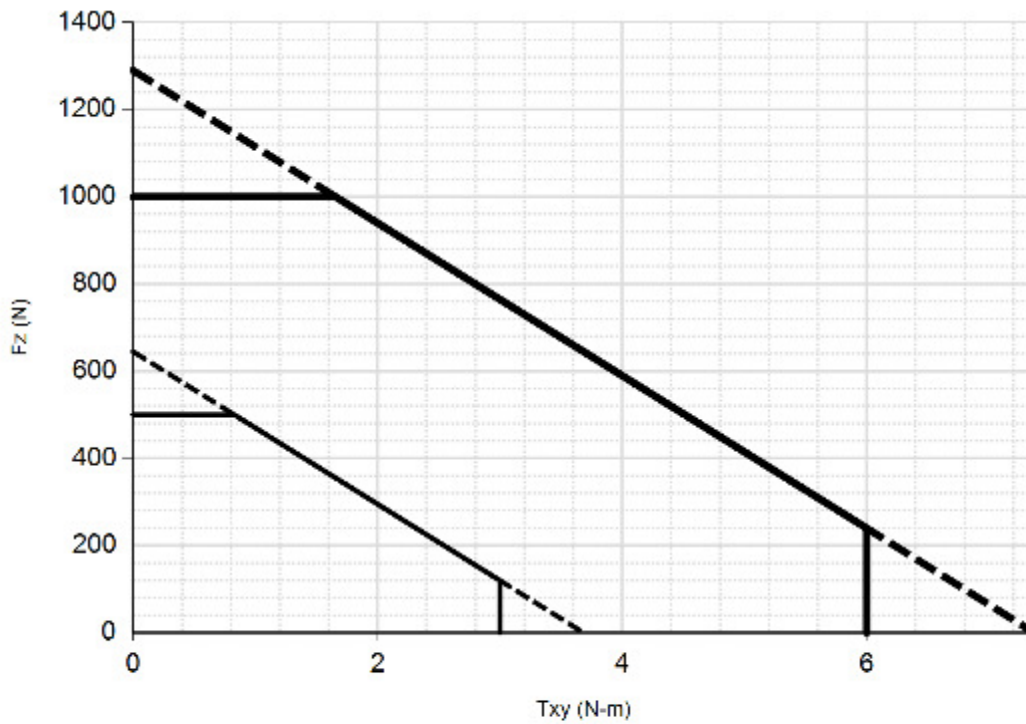
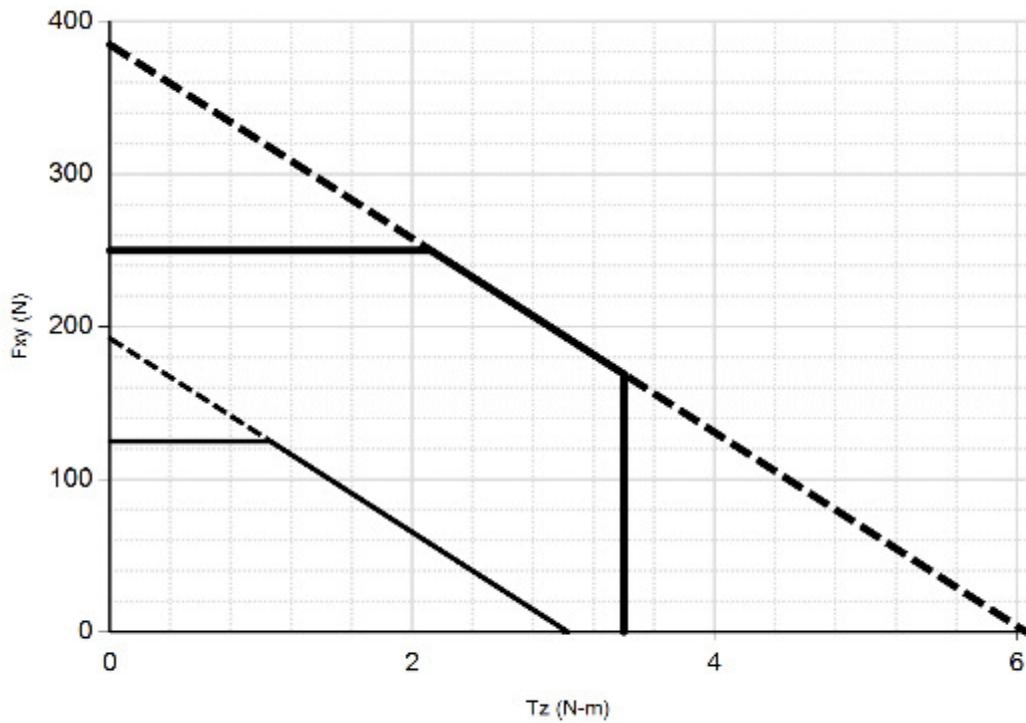

— SI-125-3 - - - SI-250-6

4.4.6 Nano25-E Transducer

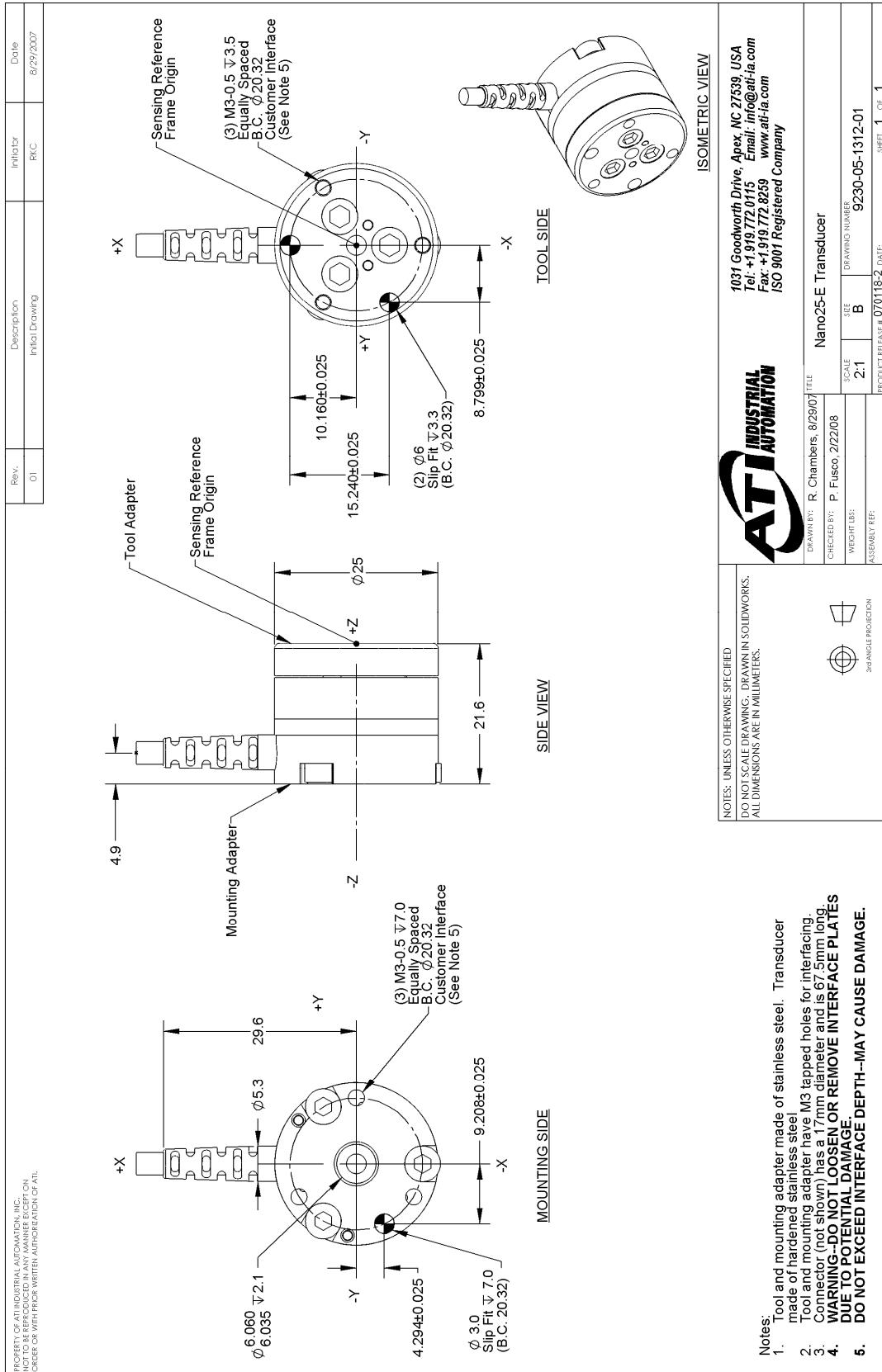

4.4.8 Nano25 IP65/IP68 Transducer with Radial Cable Exit

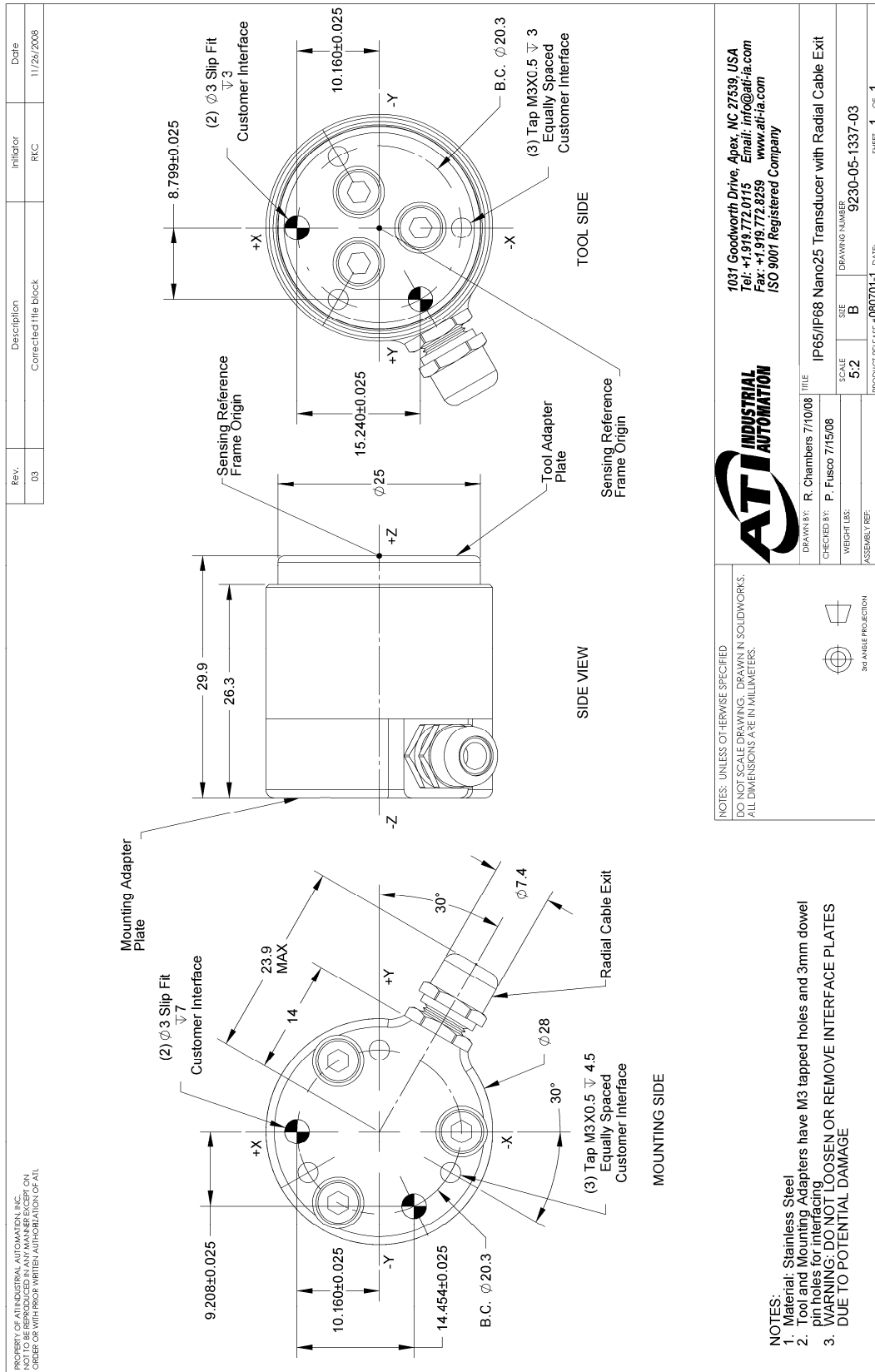

4.4.9 Legacy Nano25 Transducer

REV.	DESCRIPTION	INITIALS	DATE
13	Rev 7/6/06; Acc-F cable exit.	CCS	3/15/2010

MOUNTING SIDE

TOOL SIDE

SIDE VIEW

NANO25-R ISOMETRIC VIEW

ALTERNATE CABLE EXIT NANO25-A

ALTERNATE CABLE EXIT NANO25-E

NOTES: UNLESS OTHERWISE SPECIFIED DO NOT SCALE DRAWING. DRAWN IN SOLIDWORKS. ALL DIMENSIONS ARE IN MILLIMETERS.

1. Mounting Adapter, Tool Adapter, and Transducer made of Stainless Steel.
2. WARNING: DO NOT LOOSEN OR REMOVE INTERFACE PLATES OR CABLE FITTING DUE TO POTENTIAL DAMAGE.
3. DO NOT EXCEED INTERFACE DEPTH, MAY CAUSE DAMAGE.
 4. Connector (not shown) has 17mm diameter and is 67.5mm long.

ATI INDUSTRIAL AUTOMATION	
1031 Goodworth Drive, Apex, NC 27539 USA Tel: +1 919 772 0115 Email: info@ati-ia.com Fax: +1 919 772 8259 www.ati-ia.com ISO 9001 Registered Company www.ati-ia.com	
PROPERTY OF INDUSTRIAL AUTOMATION, INC. NOT TO BE REPRODUCED IN ANY MANNER EXCEPT BY ORDER OR WRITTEN AUTHORIZATION OF ATI.	
DRAWN BY: B. Digoso 3/8/00	TITLE: Nano25 Transducer
CHECKED BY: P. Fusco 7/17/06	DRAWING NUMBER: 9230-05-1083
WEIGHT (KG):	SCALE: 2:1
ASSEMBLY REF:	SIZE: B
PRODUCT RELEASE #:	SHEET: 2/3
DATE:	REVISION: 13

4.5 Nano43

4.5.1 Calibration Specifications (excludes CTL calibrations)

US (English)

Calibration	Fx,Fy	Fz	Tx,Ty	Tz	Fx,Fy	Fz	Tx,Ty	Tz
US-4-2	4 lbf	4 lbf	2 lbf-in	2 lbf-in	1/1160 lbf	1/1160 lbf	1/2320 lbf-in	1/2320 lbf-in
US-8-4	8 lbf	8 lbf	4 lbf-in	4 lbf-in	1/580 lbf	1/580 lbf	1/1160 lbf-in	1/1160 lbf-in
	SENSING RANGES				RESOLUTION*			

SI (Metric)

Calibration	Fx,Fy	Fz	Tx,Ty	Tz	Fx,Fy	Fz	Tx,Ty	Tz
SI-18-0.25	18 N	18 N	250 Nmm	250 Nmm	1/256 N	1/256 N	1/20 Nmm	1/20 Nmm
SI-36-0.5	36 N	36 N	500 Nmm	500 Nmm	1/128 N	1/128 N	1/10 Nmm	1/10 Nmm
	SENSING RANGES				RESOLUTION*			

* DAQ resolutions are typical for a 16-bit data acquisition system.

These system resolutions quoted are the effective resolution after dropping eight counts of noise. The effective resolution can be improved with filtering. NOTE: Applied loads must be within range in each of the six axes for the F/T sensor to measure correctly.

4.5.2 CTL Calibration Specifications

US (English)

Calibration	Fx,Fy	Fz	Tx,Ty	Tz	Fx,Fy	Fz	Tx,Ty	Tz
US-4-2	4 lbf	4 lbf	2 lbf-in	2 lbf-in	1/580 lbf	1/580 lbf	1/1160 lbf-in	1/1160 lbf-in
US-8-4	8 lbf	8 lbf	4 lbf-in	4 lbf-in	1/290 lbf	1/290 lbf	1/580 lbf-in	1/580 lbf-in
SENSING RANGES				RESOLUTION				

SI (Metric)

Calibration	Fx,Fy	Fz	Tx,Ty	Tz	Fx,Fy	Fz	Tx,Ty	Tz
SI-18-0.25	18 N	18 N	250 Nmm	250 Nmm	1/128 N	1/128 N	1/10 Nmm	1/10 Nmm
SI-36-0.5	36 N	36 N	500 Nmm	500 Nmm	1/64 N	1/64 N	1/5 Nmm	1/5 Nmm
SENSING RANGES				RESOLUTION				

US (English)

Calibration	Fx,Fy	Fz	Tx,Ty, Tz	Fx,Fy	Fz	Tx,Ty, Tz
US-4-2	±4 lbf	±4 lbf	2 lbf-in	0.4 lbf/V	0.4 lbf/V	0.2 lbf-in/V
US-8-4	±8 lbf	±8 lbf	±4 lbf-in	0.8 lbf/V	0.8 lbf/V	0.4 lbf-in/V
Analog Output Range			Analog ±10V Sensitivity‡			

SI (Metric)

Calibration	Fx,Fy	Fz	Tx,Ty, Tz	Fx,Fy	Fz	Tx,Ty, Tz
SI-18-0.25	±18 N	±18 N	±250 Nmm	1.8 N/V	1.8 N/V	25 Nmm/V
SI-36-0.5	±36 N	±36 N	±500 Nmm	3.6 N/V	3.6 N/V	50 Nmm/V
Analog Output Range			Analog ±10V Sensitivity‡			

Counts Value

Calibration	Fx, Fy, Fz	Tx, Ty, Tz	Fx, Fy, Fz	Tx, Ty, Tz
US-4-2	4640 / lbf	9280 / lbf-in	1024 / N	80 / Nmm
US-8-4	2320 / lbf	4640 / lbf-in	512 / N	40 / Nmm
Tool Transform Factor	0.005 in/unit		0.128 mm/unit	
Counts Value – US (English)			Counts Value – SI (Metric)	

CTL resolutions are typical. System resolutions quoted are the effective resolution after dropping eight counts of noise. The effective resolution can be improved with filtering. NOTE: Applied loads must be within range in each of the six axes for the F/T sensor to measure correctly.

‡ ±5V Sensitivity values are double the listed ±10V Sensitivity values.

4.5.3 Nano43 Physical Properties US (English)

Single-Axis Overload	
Fxy	±68 lbf
Fz	±86 lbf
Txy	±29 lbf-in
Tz	±41 lbf-in
Stiffness (Calculated)	
X-axis & Y-axis forces (Kx, Ky)	2.9x10 ⁴ lb/in
Z-axis force (Kz)	2.9x10 ⁴ lb/in
X-axis & Y-axis torque (Ktx, Kty)	6.8x10 ³ lbf-in/rad
Z-axis torque (Ktz)	1.0x10 ⁴ lbf-in/rad
Resonant Frequency (Measured)	
Fx, Fy, Tz	2800 Hz
Fz, Tx, Ty	2300 Hz
Physical Specifications	
Weight*	0.085 lb
Diameter*	1.7 in
Height*	0.45 in

SI (Metric)

Single-Axis Overload	
Fxy	±300 N
Fz	±380 N
Txy	±3.3 Nm
Tz	±4.6 Nm
Stiffness (Calculated)	
X-axis & Y-axis forces (Kx, Ky)	5.2x10 ⁶ N/m
Z-axis force (Kz)	5.2x10 ⁶ N/m
X-axis & Y-axis torque (Ktx, Kty)	7.7x10 ² Nm/rad
Z-axis torque (Ktz)	1.1x10 ³ Nm/rad
Resonant Frequency (Measured)	
Fx, Fy, Tz	2800 Hz
Fz, Tx, Ty	2300 Hz
Physical Specifications	
Weight*	0.0386 kg
Diameter*	43 mm
Height*	12 mm

* Specifications include standard interface plates.

4.5.4 Nano43 (US Calibration Complex Loading)

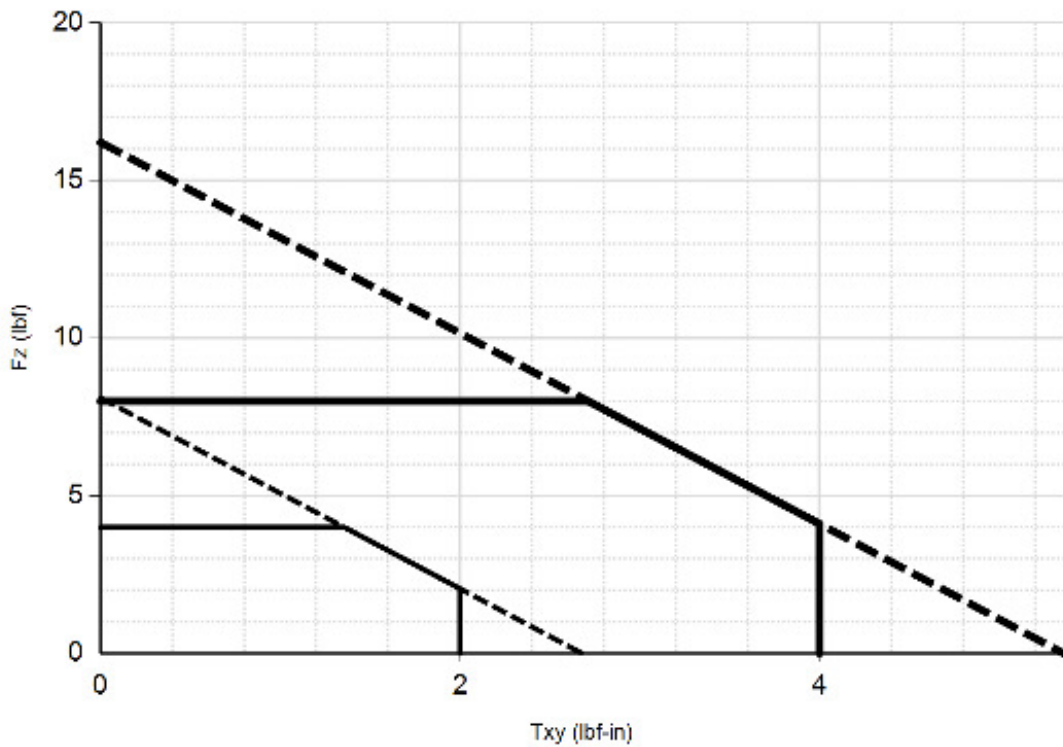
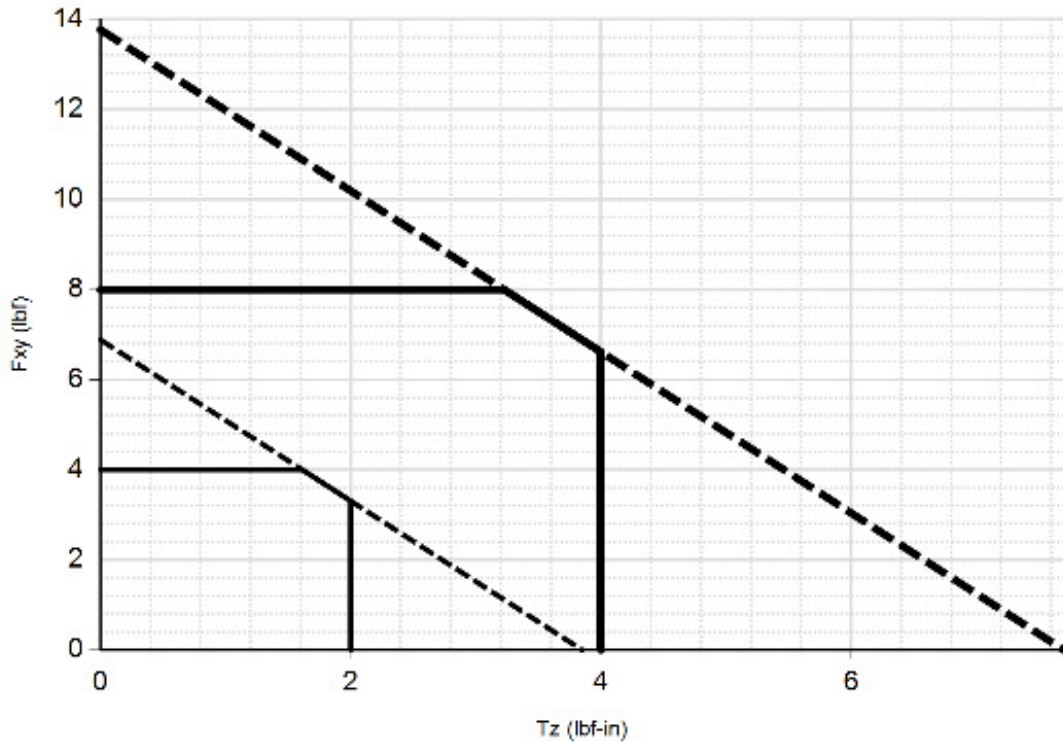

— US-4-2 — US-8-4

4.5.5 Nano43 (SI Calibration Complex Loading)

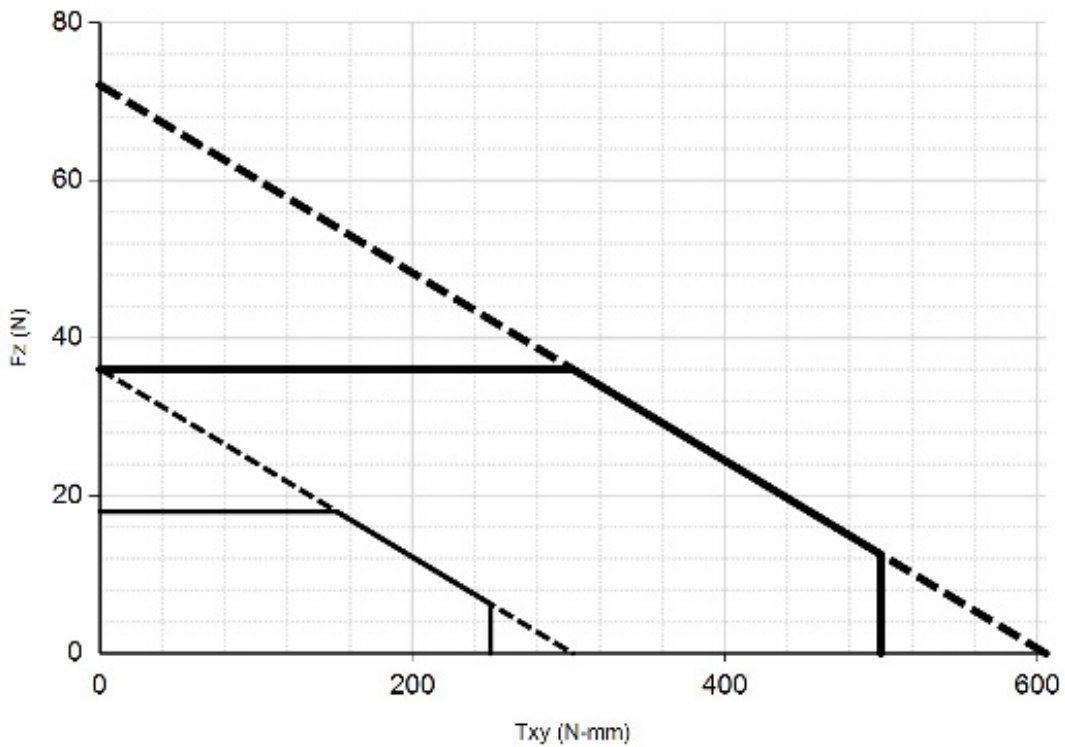
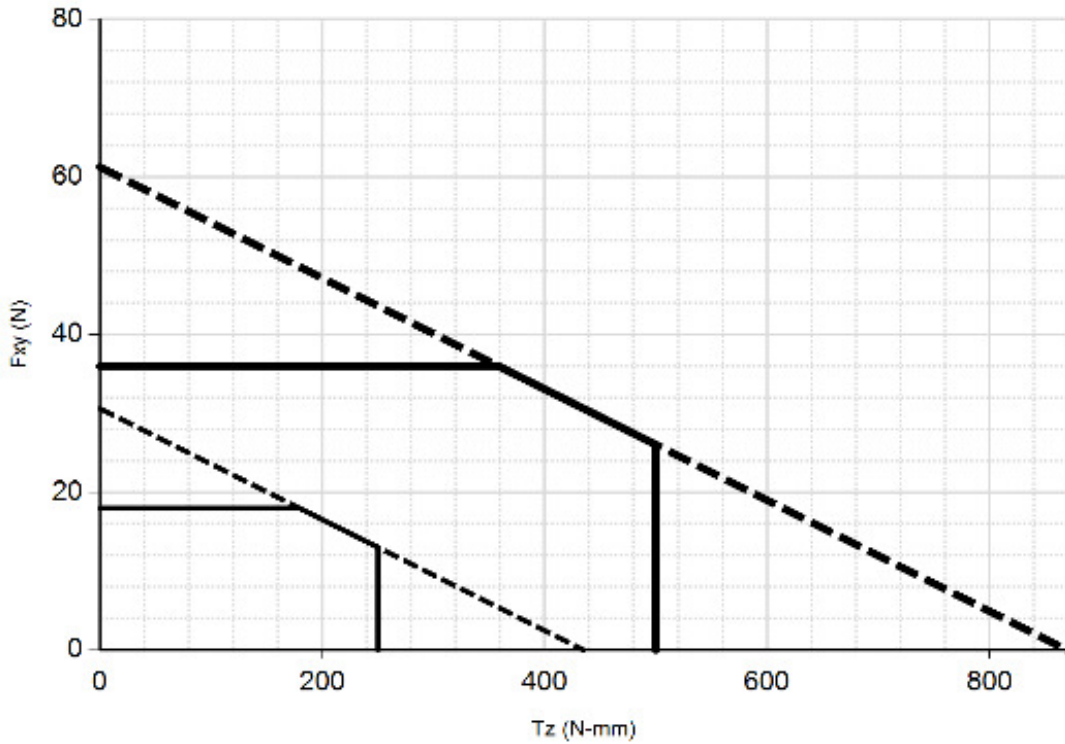

— SI-18-0.25 — SI-36-0.5

4.5.6 Nano43 Transducer

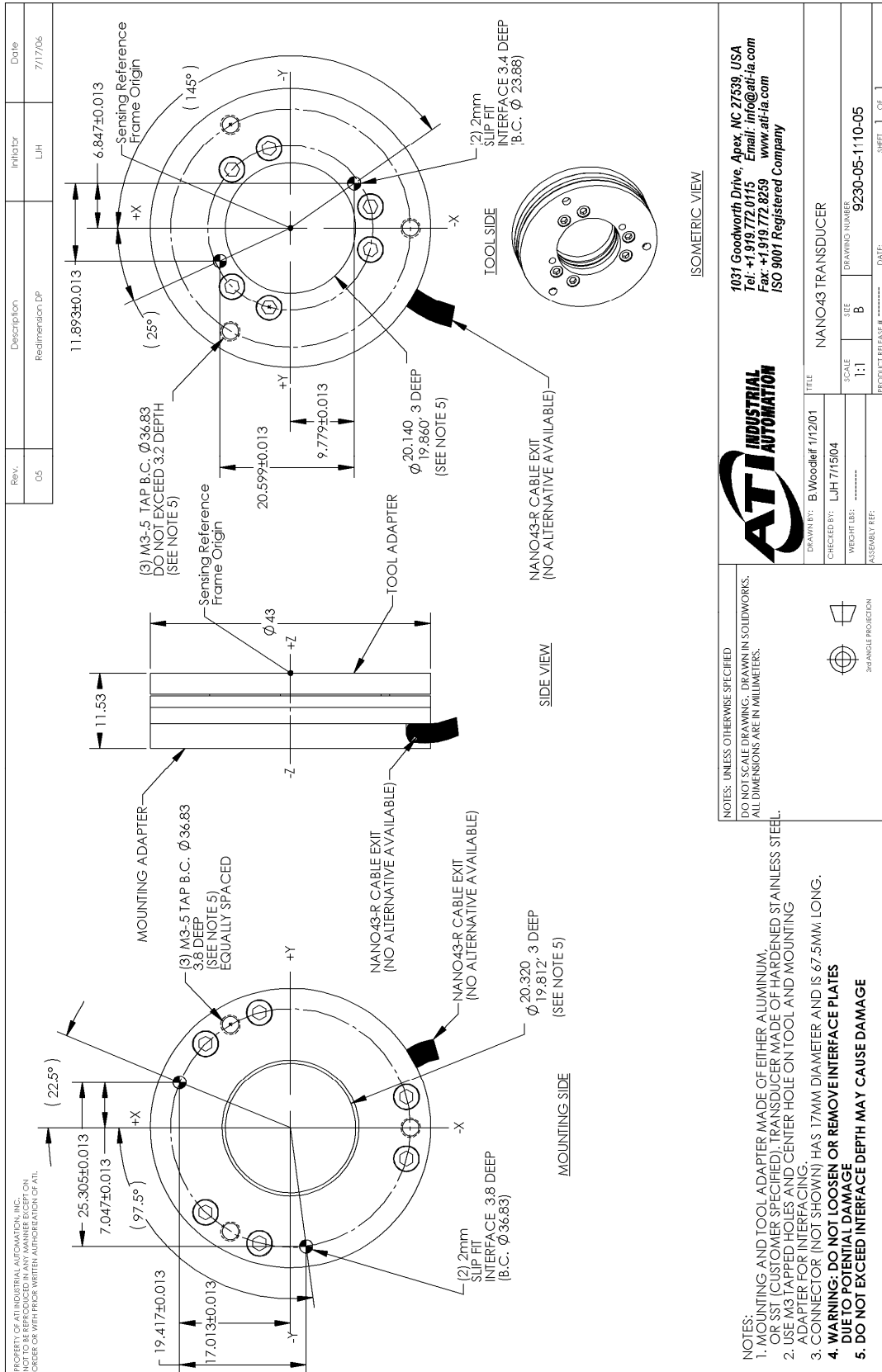

4.6 Mini40

4.6.1 Calibration Specifications (excludes CTL calibrations)

US (English)

Calibration	Fx,Fy	Fz	Tx,Ty	Tz	Fx,Fy	Fz	Tx,Ty	Tz
US-5-10	5 lbf	15 lbf	10 lbf-in	10 lbf-in	1/800 lbf	1/400 lbf	1/800 lbf-in	1/800 lbf-in
US-10-20	10 lbf	30 lbf	20 lbf-in	20 lbf-in	1/400 lbf	1/200 lbf	1/400 lbf-in	1/400 lbf-in
US-20-40	20 lbf	60 lbf	40 lbf-in	40 lbf-in	1/200 lbf	1/100 lbf	1/200 lbf-in	1/200 lbf-in
	SENSING RANGES				RESOLUTION*			

SI (Metric)

Calibration	Fx,Fy	Fz	Tx,Ty	Tz	Fx,Fy	Fz	Tx,Ty	Tz
SI-20-1	20 N	60 N	1 Nm	1 Nm	1/200 N	1/100 N	1/8000 Nm	1/8000 Nm
SI-40-2	40 N	120 N	2 Nm	2 Nm	1/100 N	1/50 N	1/4000 Nm	1/4000 Nm
SI-80-4	80 N	240 N	4 Nm	4 Nm	1/50 N	1/25 N	1/2000 Nm	1/2000 Nm
	SENSING RANGES				RESOLUTION*			

* DAQ resolutions are typical for a 16-bit data acquisition system.

These system resolutions quoted are the effective resolution after dropping four counts of noise. The effective resolution can be improved with filtering. NOTE: Applied loads must be within range in each of the six axes for the F/T sensor to measure correctly.

4.6.2 CTL Calibration Specifications

US (English)

Calibration	Fx,Fy	Fz	Tx,Ty	Tz	Fx,Fy	Fz	<u>Tx,Ty</u>	<u>Tz</u>
US-5-10	5 lbf	15 lbf	10 lbf-in	10 lbf-in	1/400 lbf	1/200 lbf	1/400 lbf-in	1/400 lbf-in
US-10-20	10 lbf	30 lbf	20 lbf-in	20 lbf-in	1/200 lbf	1/100 lbf	1/200 lbf-in	1/200 lbf-in
US-20-40	20 lbf	60 lbf	40 lbf-in	40 lbf-in	1/100 lbf	1/50 lbf	1/100 lbf-in	1/100 lbf-in
SENSING RANGES				RESOLUTION				

SI (Metric)

Calibration	Fx,Fy	Fz	Tx,Ty	Tz	Fx,Fy	Fz	<u>Tx,Ty</u>	<u>Tz</u>
SI-20-1	20 N	60 N	1 Nm	1 Nm	1/100 N	1/50 N	1/4000 Nm	1/4000 Nm
SI-40-2	40 N	120 N	2 Nm	2 Nm	1/50 N	1/25 N	1/2000 Nm	1/2000 Nm
SI-80-4	80 N	240 N	4 Nm	4 Nm	1/25 N	2/25 N	1/1000 Nm	1/1000 Nm
SENSING RANGES				RESOLUTION				

US (English)

Calibration	Fx,Fy	Fz†	Tx,Ty, Tz	Fx,Fy	Fz†	Tx,Ty, Tz
US-5-10	±5 lbf	±15 lbf	±10 lbf-in	0.5 lbf/V	1.5 lbf/V	1 lbf-in/V
US-10-20	±10 lbf	±30 lbf	±20 lbf-in	1 lbf/V	3 lbf/V	2 lbf-in/V
US-20-40	±20 lbf	±60 lbf	±40 lbf-in	2 lbf/V	6 lbf/V	4 lbf-in/V
Analog Output Range			Analog ±10V Sensitivity‡			

SI (Metric)

Calibration	Fx,Fy	Fz†	Tx,Ty, Tz	Fx,Fy	Fz†	Tx,Ty, Tz
SI-20-1	±20 N	±60 N	±1 Nm	2 N/V	6 N/V	0.1 Nm/V
SI-40-2	±40 N	±120 N	±2 Nm	4 N/V	12 N/V	0.2 Nm/V
SI-80-4	±80 N	±240 N	±4 Nm	8 N/V	24 N/V	0.4 Nm/V
Analog Output Range			Analog ±10V Sensitivity‡			

Counts Value

Calibration	Fx, Fy, Fz	Tx, Ty, Tz	Fx, Fy, Fz	Tx, Ty, Tz
US-5-10 / SI-20-1	3200 / lbf	3200 / lbf-in	800 / N	32000 / Nm
US-10-20 / SI-40-2	1600 / lbf	1600 / lbf-in	400 / N	16000 / Nm
US-20-40 / SI-80-4	800 / lbf	800 / lbf-in	200 / N	8000 / Nm
Tool Transform Factor	0.01 in/unit		0.25 mm/unit	
Counts Value – US (English)			Counts Value – SI (Metric)	

CTL resolutions are typical. System resolutions quoted are the effective resolution after dropping eight counts of noise. The effective resolution can be improved with filtering. NOTE: Applied loads must be within range in each of the six axes for the F/T sensor to measure correctly.

‡ ±5V Sensitivity values are double the listed ±10V Sensitivity values.

4.6.3 Mini40 Physical Properties
US (English)

Single-Axis Overload	
Fxy	±180 lbf
Fz	±530 lbf
Txy	±170 lbf-in
Tz	±180 lbf-in
Stiffness (Calculated)	
X-axis & Y-axis forces (Kx, Ky)	6.1x10 ⁴ lb/in
Z-axis force (Kz)	1.2x10 ⁵ lb/in
X-axis & Y-axis torque (Ktx, Kty)	2.5x10 ⁴ lbf-in/rad
Z-axis torque (Ktz)	3.6x10 ⁴ lbf-in/rad
Resonant Frequency (Measured)	
Fx, Fy, Tz	3200 Hz
Fz, Tx, Ty	4900 Hz
Physical Specifications	
Weight*	0.11 lb
Diameter*	1.6 in
Height*	0.48 in

SI (Metric)

Single-Axis Overload	
Fxy	±810 N
Fz	±2400 N
Txy	±19 Nm
Tz	±20 Nm
Stiffness (Calculated)	
X-axis & Y-axis forces (Kx, Ky)	1.1x10 ⁷ N/m
Z-axis force (Kz)	2.0x10 ⁷ N/m
X-axis & Y-axis torque (Ktx, Kty)	2.8x10 ³ Nm/rad
Z-axis torque (Ktz)	4.0x10 ³ Nm/rad
Resonant Frequency (Measured)	
Fx, Fy, Tz	3200 Hz
Fz, Tx, Ty	4900 Hz
Physical Specifications	
Weight*	0.0499 kg
Diameter*	40 mm
Height*	12 mm

* Specifications include standard interface plates.

4.6.4 Mini40 (US Calibration Complex Loading)

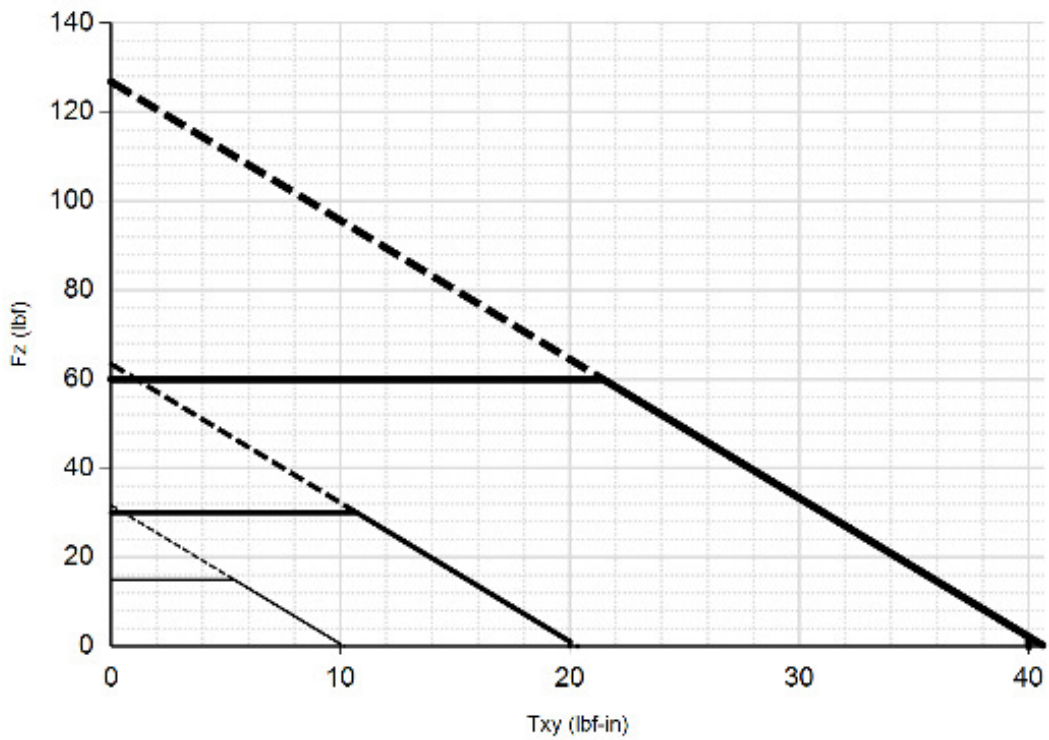
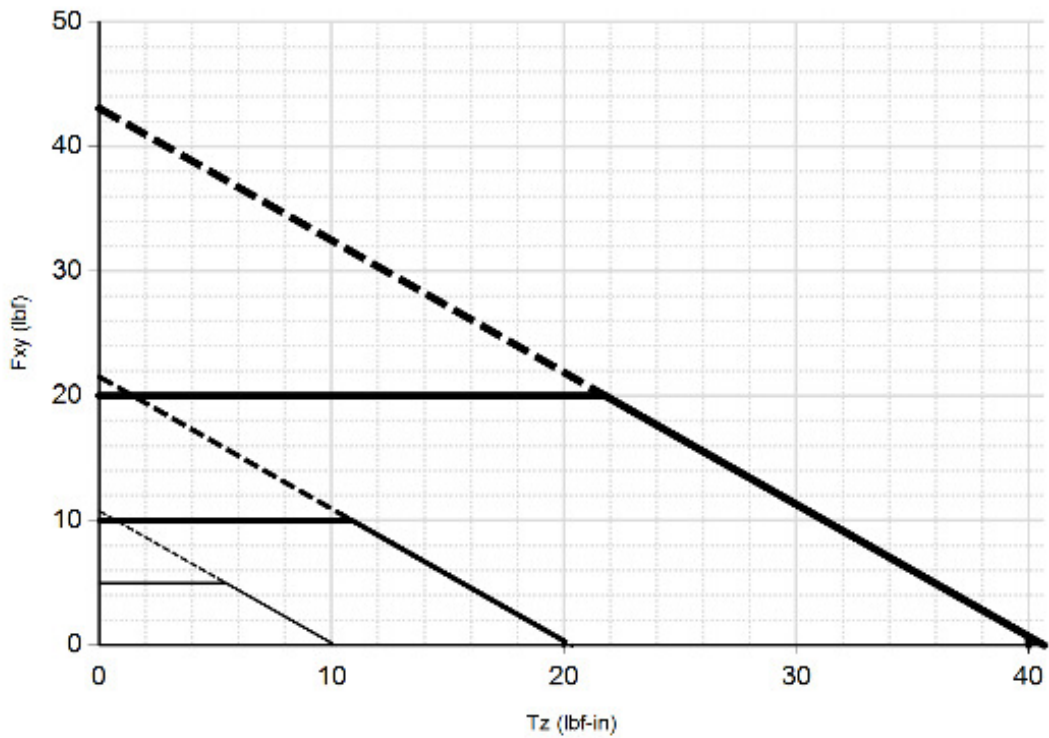

US-5-10
 US-10-20
 US-20-40

4.6.5 Mini40 (SI Calibration Complex Loading)

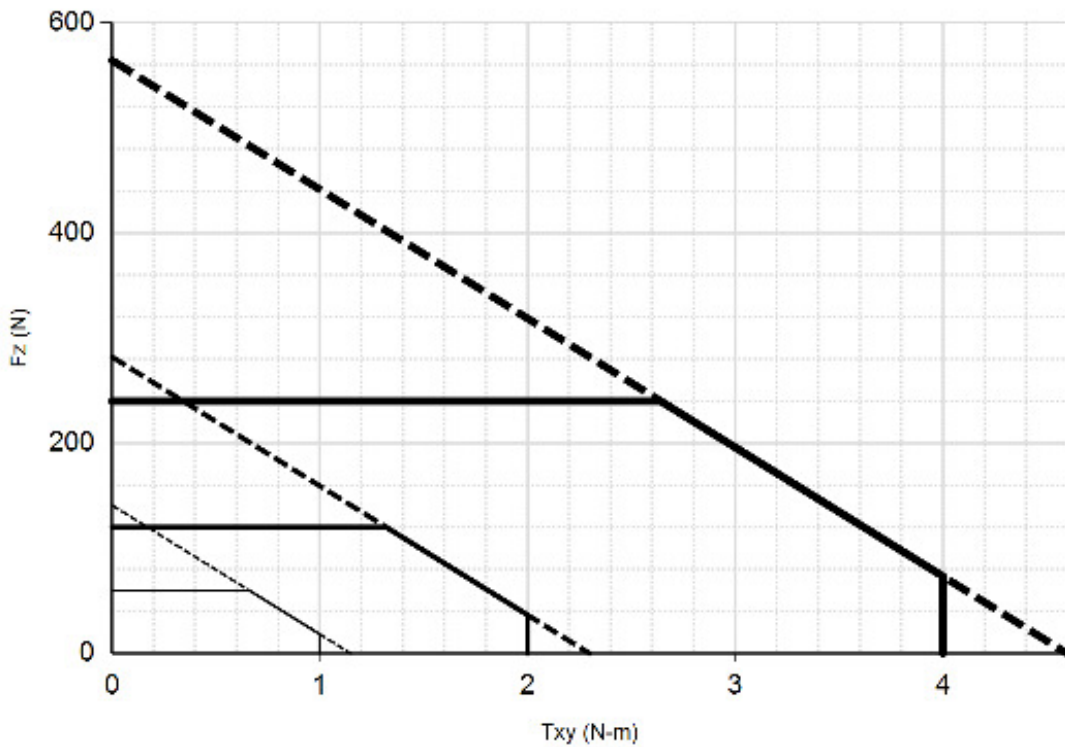
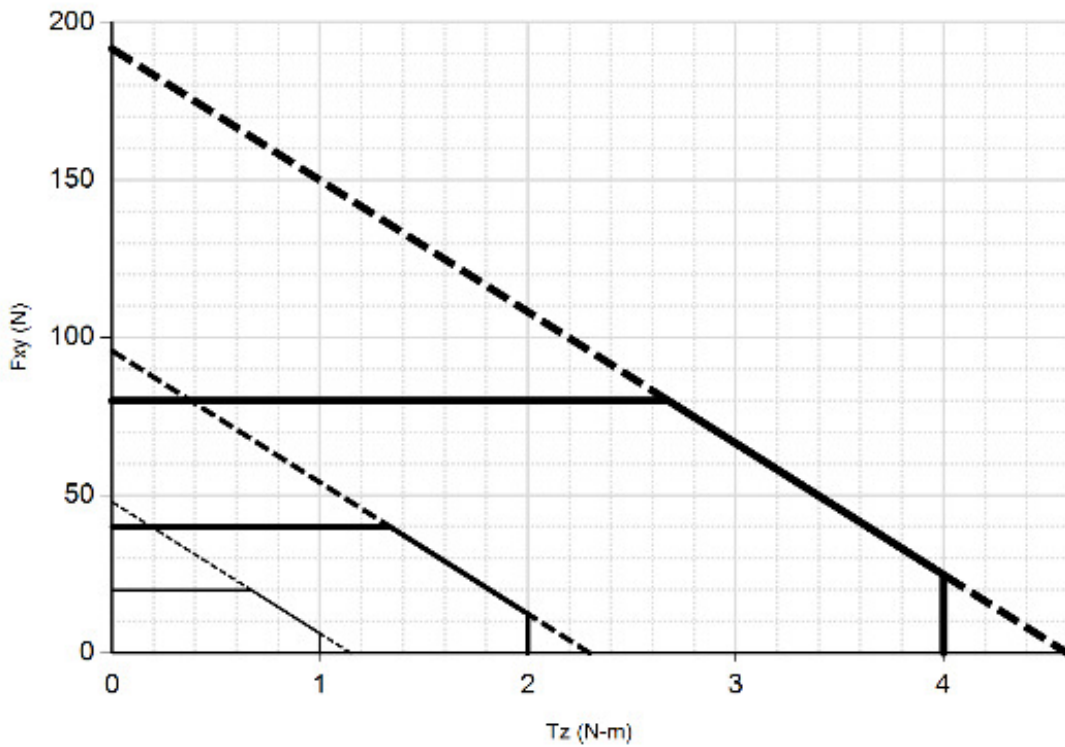

SI-20-1
 SI-40-2
 SI-80-4

4.6.7 Legacy Mini40 Transducer

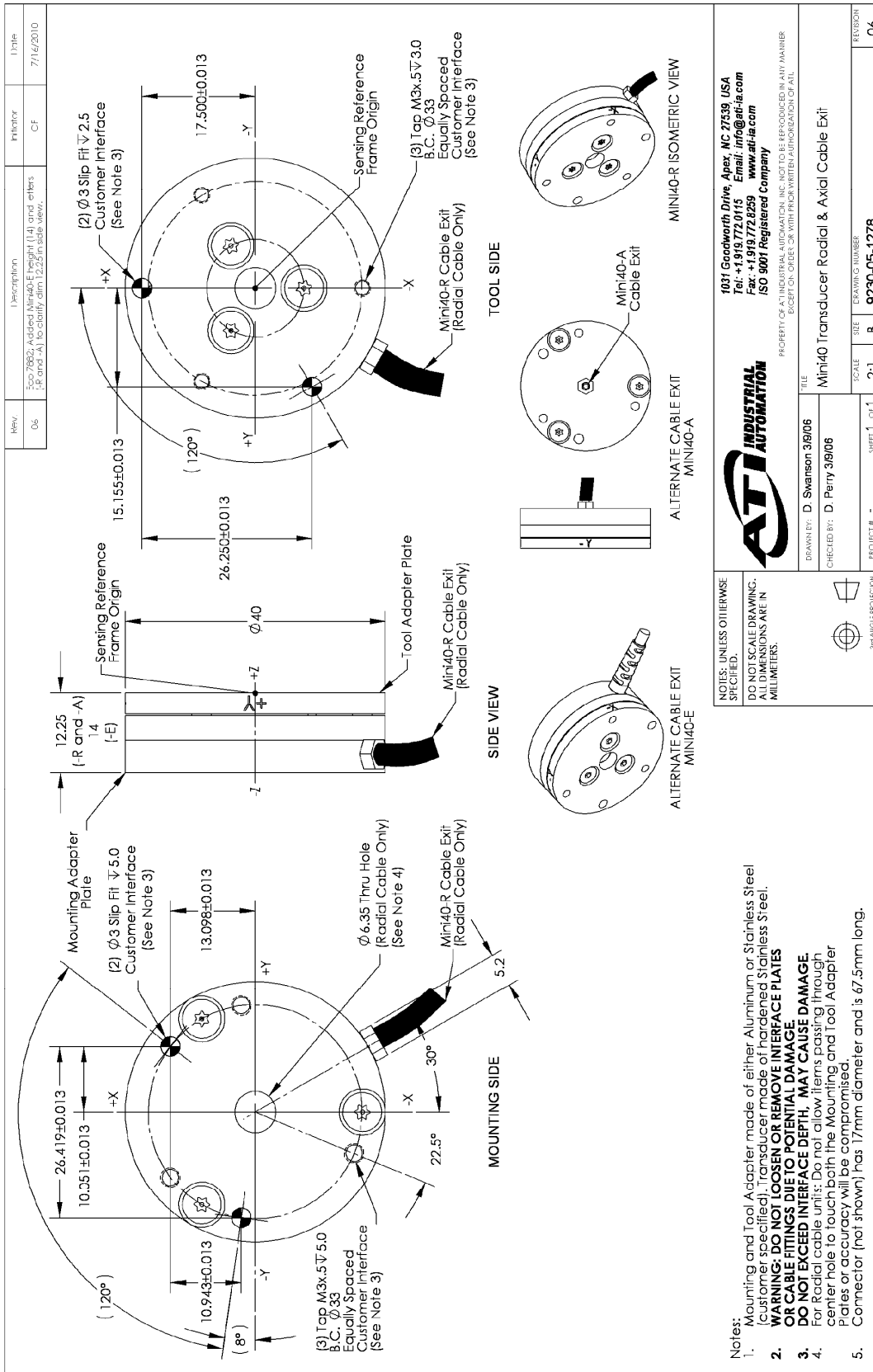

ATI INDUSTRIAL AUTOMATION

1031 Goodworth Drive Apex, NC 27539 USA
 Tel: +1.919.772.0115 Email: info@ati-ia.com
 Fax: +1.919.772.8259 www.ati-ia.com
 ISO 9001 Registered Company

PROPERTY OF ATI INDUSTRIAL AUTOMATION, INC. NOT TO BE REPRODUCED IN ANY MANNER EXCEPT BY ORDER OR WITH PRIOR WRITTEN PERMISSION OF ATI.

DRAWN BY: D. Swanson 3/8/06
 CHECKED BY: D. Perry 3/8/06

TITLE: Mini40 Transducer Radial & Axial Cable Exit

SCALE: 2:1
 SIZE: B
 DRAWING NUMBER: 9230-05-1278

PROJECT # - SHEET 1 OF 1
 REVISION: 06

NOTES: UNLESS OTHERWISE SPECIFIED, ALL DIMENSIONS ARE IN MILLIMETERS.

30° ANGLE PROJECTION

4.7 Mini45

4.7.1 Calibration Specifications (excludes CTL calibrations)

US (English)

Calibration	Fx,Fy	Fz	Tx,Ty	Tz	Fx,Fy	Fz	Tx,Ty	Tz
US-30—0	30 lbf	60 lbf	40 lbf-in	40 lbf-in	1/80 lbf	1/80 lbf	1/88 lbf-in	1/176 lbf-in
US-60—80	60 lbf	120 lbf	80 lbf-in	80 lbf-in	1/40 lbf	1/40 lbf	1/44 lbf-in	1/88 lbf-in
US-120—160	120 lbf	240 lbf	160 lbf-in	160 lbf-in	1/20 lbf	1/20 lbf	1/22 lbf-in	1/44 lbf-in
	SENSING RANGES				RESOLUTION*			

SI (Metric)

Calibration	Fx,Fy	Fz	Tx,Ty	Tz	Fx,Fy	Fz	Tx,Ty	Tz
SI-145—5	145 N	290 N	5 Nm	5 Nm	1/16 N	1/16 N	1/752 Nm	1/1504 Nm
SI-290—10	290 N	580 N	10 Nm	10 Nm	1/8 N	1/8 N	1/376 Nm	1/752 Nm
SI-580—20	580 N	1160 N	20 Nm	20 Nm	1/4 N	1/4 N	1/188 Nm	1/376 Nm
	SENSING RANGES				RESOLUTION*			

* DAQ resolutions are typical for a 16-bit data acquisition system.

These system resolutions quoted are the effective resolution after dropping four counts of noise. The effective resolution can be improved with filtering. NOTE: Applied loads must be within range in each of the six axes for the F/T sensor to measure correctly.

4.7.2 CTL Calibration Specifications

US (English)

Calibration	Fx,Fy	Fz	Tx,Ty	Tz	Fx,Fy	Fz	Tx,Ty	Tz
US-30-40	30 lbf	60 lbf	40 lbf-in	40 lbf-in	1/40 lbf	1/40 lbf	1/44 lbf-in	1/88 lbf-in
US-60-80	60 lbf	120 lbf	80 lbf-in	80 lbf-in	1/20 lbf	1/20 lbf	1/22 lbf-in	1/44 lbf-in
US-120-160	120 lbf	240 lbf	160 lbf-in	160 lbf-in	1/10 lbf	1/10 lbf	1/11 lbf-in	1/22 lbf-in
SENSING RANGES				RESOLUTION				

SI (Metric)

Calibration	Fx,Fy	Fz	Tx,Ty	Tz	Fx,Fy	Fz	Tx,Ty	Tz
SI-145-5	145 N	290 N	5 Nm	5 Nm	1/8 N	1/8 N	1/376 Nm	1/752 Nm
SI-290-10	290 N	580 N	10 Nm	10 Nm	1/4 N	1/4 N	1/188 Nm	1/376 Nm
SI-580-20	580 N	1160 N	20 Nm	20 Nm	1/2 N	1/2 N	1/94 Nm	1/188 Nm
SENSING RANGES				RESOLUTION				

US (English)

Calibration	Fx,Fy	Fz†	Tx,Ty, Tz	Fx,Fy	Fz†	Tx,Ty, Tz
US-30-40	±30 lbf	±60 lbf	±40 lbf-in	3 lbf/V	6 lbf/V	4 lbf-in/V
US-60-80	±60 lbf	±120 lbf	±80 lbf-in	6 lbf/V	12 lbf/V	8 lbf-in/V
US-120-160	±120 lbf	±240 lbf	±160 lbf-in	12 lbf/V	24 lbf/V	16 lbf-in/V
Analog Output Range			Analog ±10V Sensitivity‡			

SI (Metric)

Calibration	Fx,Fy	Fz†	Tx,Ty, Tz	Fx,Fy	Fz†	Tx,Ty, Tz
SI-145-5	±145 N	±290 N	±5 Nm	14.5 N/V	29 N/V	0.5 Nm/V
SI-290-10	±290 N	±580 N	±10 Nm	29 N/V	58 N/V	1 Nm/V
SI-580-20	±580 N	±1160 N	±20 Nm	58 N/V	116 N/V	2 Nm/V
Analog Output Range			Analog ±10V Sensitivity‡			

Counts Value

Calibration	Fx, Fy, Fz	Tx, Ty, Tz	Fx, Fy, Fz	Tx, Ty, Tz
US-30-40 / SI-145-5	640 / lbf	704 / lbf-in	128 / N	6016 / Nm
US-60-80 / SI-290-10	320 / lbf	352 / lbf-in	64 / N	3008 / Nm
US-120-160 / SI-580-20	160 / lbf	176 / lbf-in	32 / N	1504 / Nm
Tool Transform Factor	0.009091 in/unit		0.21277 mm/unit	
Counts Value – US (English)			Counts Value – SI (Metric)	

CTL resolutions are typical. System resolutions quoted are the effective resolution after dropping eight counts of noise. The effective resolution can be improved with filtering. NOTE: Applied loads must be within range in each of the six axes for the F/T sensor to measure correctly.

‡ ±5V Sensitivity values are double the listed ±10V Sensitivity values.

4.7.3 Mini45 Physical Properties
US (English)

Single-Axis Overload	
Fxy	±1100 lbf
Fz	±2300 lbf
Txy	±1000 lbf-in
Tz	±1200 lbf-in
Stiffness (Calculated)	
X-axis & Y-axis forces (Kx, Ky)	4.2x10 ⁵ lb/in
Z-axis force (Kz)	5.6x10 ⁵ lb/in
X-axis & Y-axis torque (Ktx, Kty)	1.5x10 ⁵ lbf-in/rad
Z-axis torque (Ktz)	3.1x10 ⁵ lbf-in/rad
Resonant Frequency (Measured)	
Fx, Fy, Tz	5600 Hz
Fz, Tx, Ty	5400 Hz
Physical Specifications	
Weight*	0.202 lb
Diameter*	1.8 in
Height*	0.62 in

SI (Metric)

Single-Axis Overload	
Fxy	±5100 N
Fz	±10000 N
Txy	±110 Nm
Tz	±140 Nm
Stiffness (Calculated)	
X-axis & Y-axis forces (Kx, Ky)	7.4x10 ⁷ N/m
Z-axis force (Kz)	9.8x10 ⁷ N/m
X-axis & Y-axis torque (Ktx, Kty)	1.7x10 ⁴ Nm/rad
Z-axis torque (Ktz)	3.5x10 ⁴ Nm/rad
Resonant Frequency (Measured)	
Fx, Fy, Tz	5600 Hz
Fz, Tx, Ty	5400 Hz
Physical Specifications	
Weight*	0.0916 kg
Diameter*	45 mm
Height*	16 mm

* Specifications include standard interface plates.

4.7.4 Mini45 (US Calibration Complex Loading)

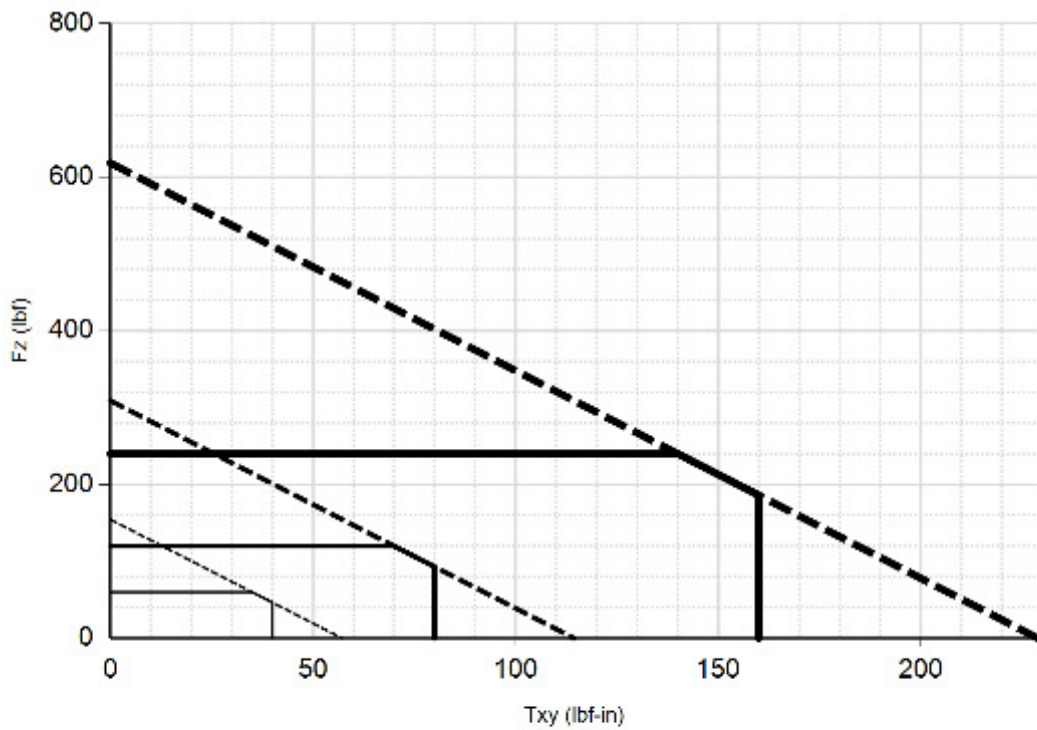
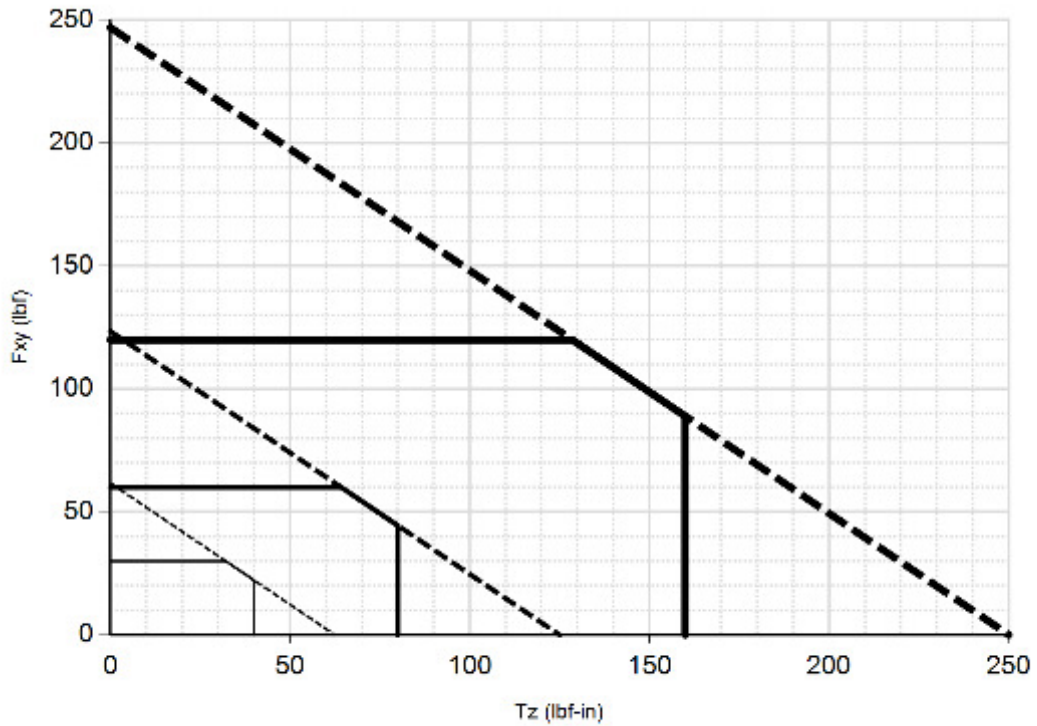

US-30-40
 US-60-80
 US-120-160

4.7.5 Mini45 (SI Calibration Complex Loading)

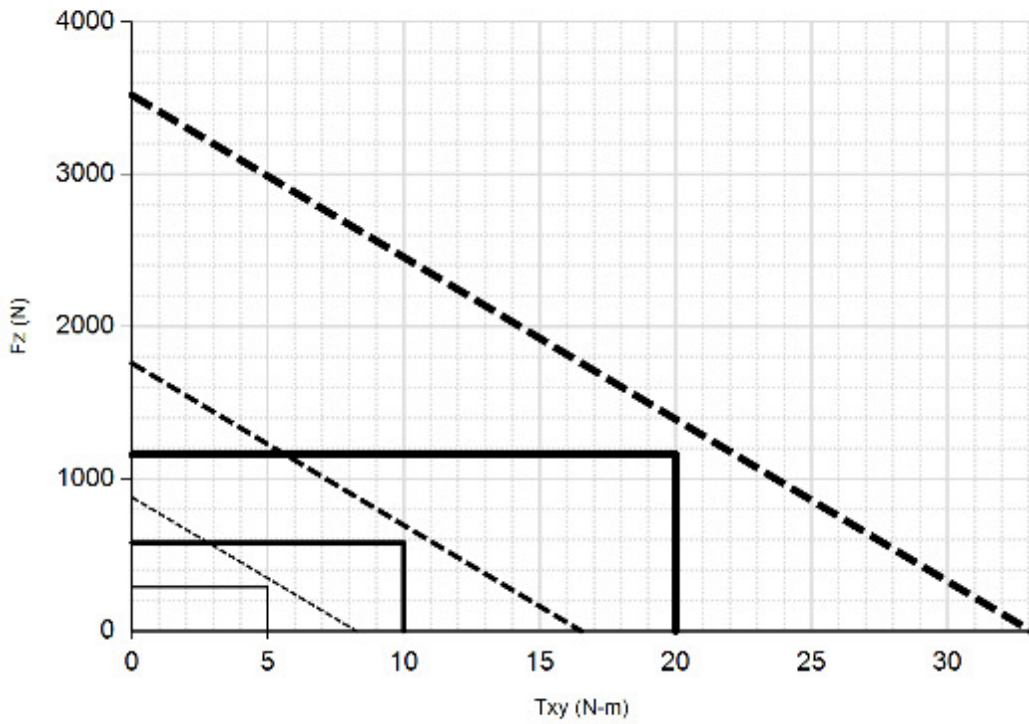
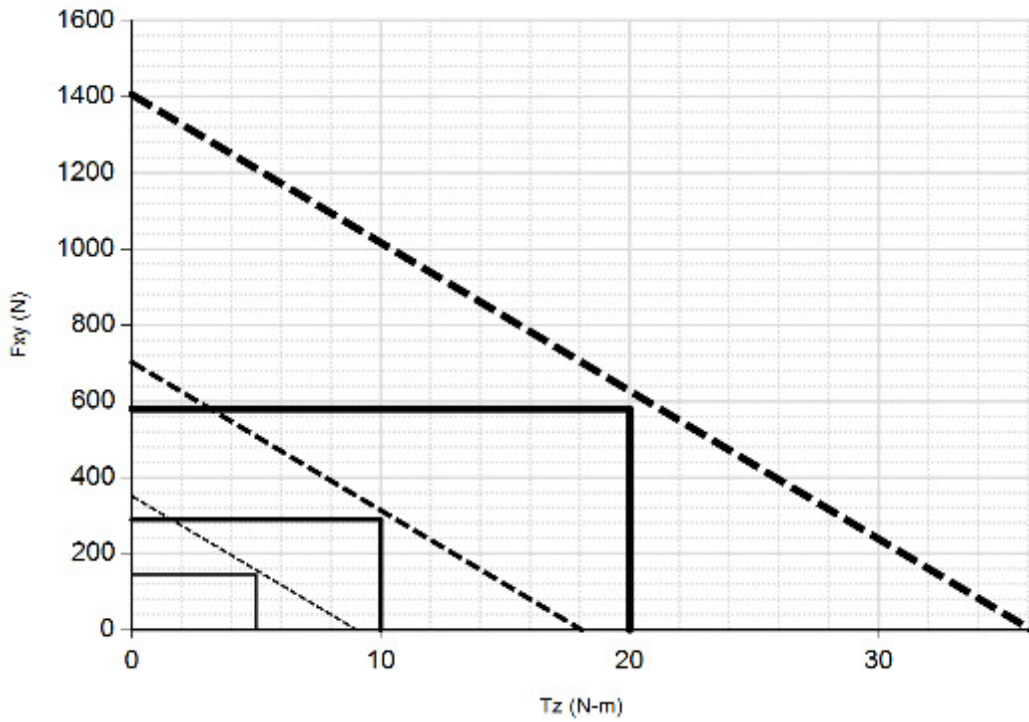

SI-145-5
 SI-290-10
 SI-580-20

4.7.6 Mini45-E Transducer

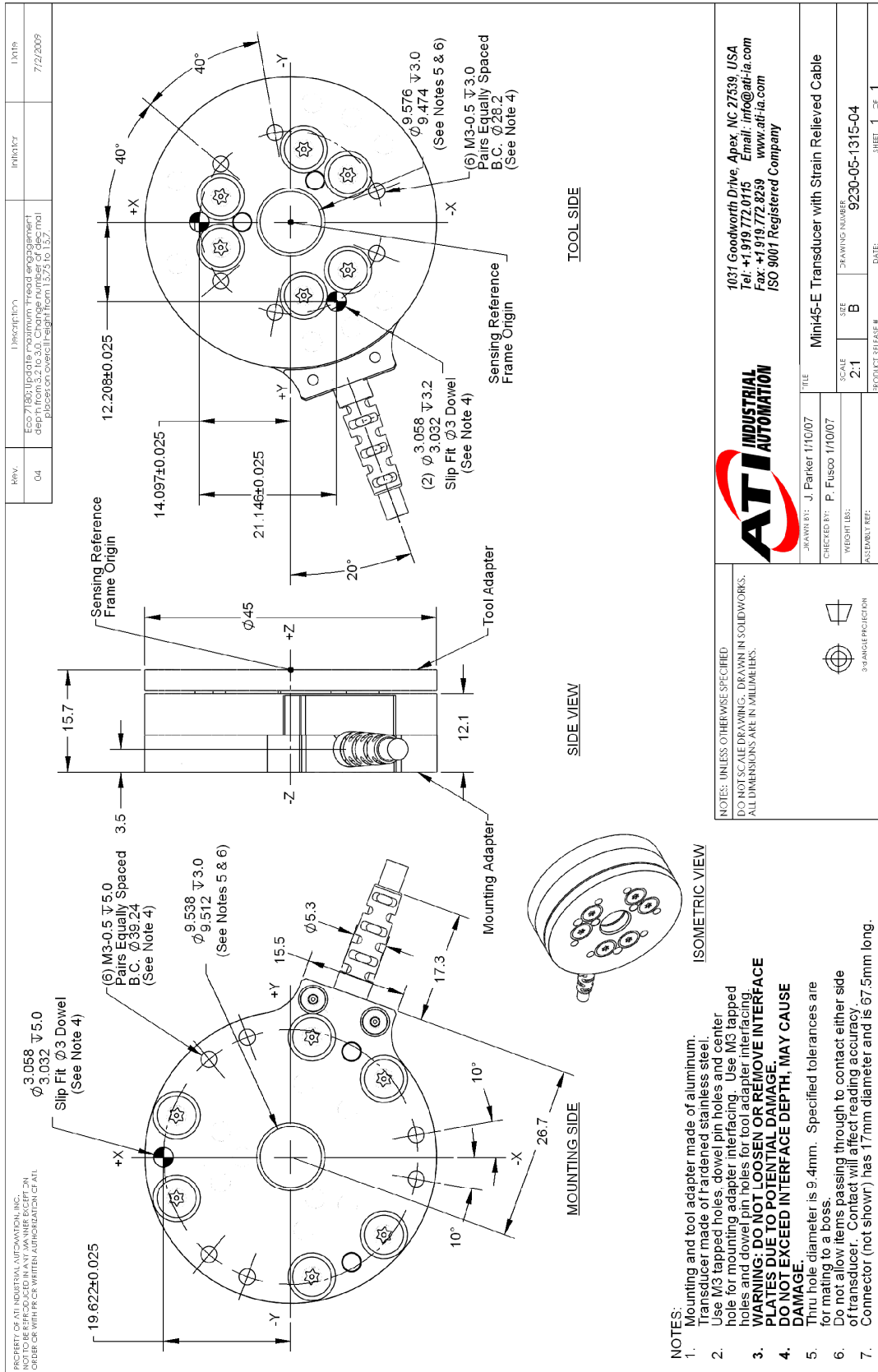

1031 Goodworth Drive, Apex, NC 27539, USA
 Tel: +1.919.772.0115 Email: info@ati-ia.com
 Fax: +1.919.772.8259 www.ati-ia.com
 ISO 9001 Registered Company

DRAWN BY: J. Parker 1/10/07	TITLE: Mini45-E Transducer with Strain Relieved Cable	SCALE: 2:1	DRAWING NUMBER: 9230-05-1315-04
CHECKED BY: P. Fusco 1/10/07	WEIGHT LIB: B		
ASSEMBLY REF:		DATE: SHEET 1 OF 1	

NOTES: UNLESS OTHERWISE SPECIFIED,
 DO NOT SCALE DRAWINGS. DRAWN IN SOLIDWORKS.
 ALL DIMENSIONS ARE IN MILLIMETERS.

3/8 ANGLE PITCH

4.7.7 Legacy Mini45 Transducer

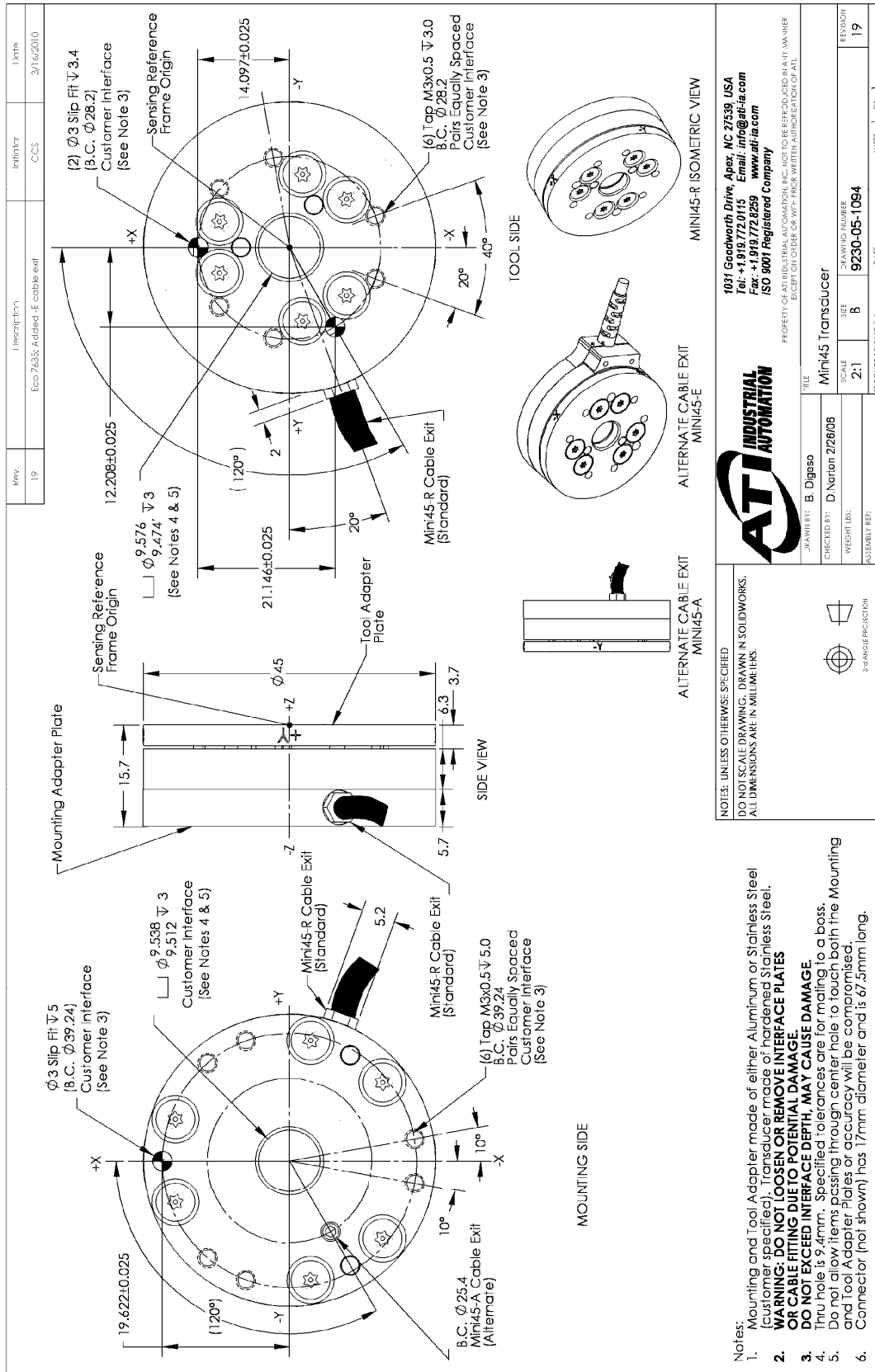

NOTES: UNLESS OTHERWISE SPECIFIED
 DO NOT SCALE DRAWING. DRAWN IN SOLIDWORKS.
 ALL DIMENSIONS ARE IN MILLIMETERS.

1. Mounting and Tool Adapter made of either Aluminum or Stainless Steel (customer specified). Transducer made of hardened Stainless Steel.
2. WARNING: DO NOT LOOSEN OR REMOVE INTERFACE PLATES OR CABLE FITTING DUE TO POTENTIAL DAMAGE.
3. DO NOT EXCEED INTERFACE DEPTH. MAY CAUSE DAMAGE.
4. Thru hole is 9.4mm. Specified tolerances are for mating to a boss. Do not allow items passing through center hole to touch both the Mounting and Tool Adapter Plates or accuracy will be compromised.
5. Connector (not shown) has 17mm diameter and is 67.5mm long.
6.

PROPERTY OF INDUSTRIAL AUTOMATION, INC. NOT TO BE REPRODUCED IN ANY MANNER EXCEPT BY ORDER OR WRITTEN PERMISSION OF ATI.

TITLE	Mini45 Transducer
DRAWN BY:	B. Diggs
CHECKED BY:	D. Norton 2/26/08
SCALE	2:1
WEIGHT (LBS)	B
ASSEMBLY REF:	9230-05-1094
DRAWING NUMBER	
REVISION	19

1031 Goodworth Drive, Apex, NC 27539 USA
 Tel: +1.919.772.0115 Email: info@ati-ia.com
 Fax: +1.919.772.8259 www.ati-ia.com
 ISO 9001 Registered Company

PRODUCT RELEASE # - - - - - SHEET 3 OF 3

4.8 Mini85

4.8.1 Calibration Specifications (excludes CTL calibrations)

US (English)

Calibration	Fx,Fy	Fz	Tx,Ty	Tz	Fx,Fy	Fz	Tx,Ty	Tz
US-105–185	105 lbf	210 lbf	185 lbf-in	185 lbf-in	13/800 lbf	23/1000 lbf	107/4000 lbf-in	37/2000 lbf-in
US-210–370	210 lbf	420 lbf	370 lbf-in	370 lbf-in	129/4000 lbf	23/500 lbf	107/2000 lbf-in	37/1000 lbf-in
US-420–740	420 lbf	840 lbf	740 lbf-in	740 lbf-in	257/4000 lbf	367/4000 lbf	427/4000 lbf-in	37/500 lbf-in
SENSING RANGES				RESOLUTION*				

SI (Metric)

Calibration	Fx,Fy	Fz	Tx,Ty	Tz	Fx,Fy	Fz	Tx,Ty	Tz
SI-475–20	475 N	950 N	20 Nm	20 Nm	143/2000 N	51/500 N	13/4000 Nm	9/4000 Nm
SI-950–40	950 N	1900 N	40 Nm	40 Nm	571/4000 N	51/250 N	1/160 Nm	17/4000 Nm
SI-1900–80	1900 N	3800 N	80 Nm	80 Nm	571/2000 N	51/125 N	49/4000 Nm	17/2000 Nm
SENSING RANGES				RESOLUTION*				

* DAQ resolutions are typical for a 16-bit data acquisition system.

These system resolutions quoted are the effective resolution after dropping four counts of noise. The effective resolution can be improved with filtering. NOTE: Applied loads must be within range in each of the six axes for the F/T sensor to measure correctly.

4.8.2 CTL Calibration Specifications

US (English)

Calibration	Fx,Fy	Fz	Tx,Ty	Tz	Fx,Fy	Fz	Tx,Ty	Tz
US-105–185	105 lbf	210 lbf	185 lbf-in	185 lbf-in	13/400 lbf	23/500 lbf	107/2000 lbf-in	37/1000 lbf-in
US-210–370	210 lbf	420 lbf	370 lbf-in	370 lbf-in	129/2000 lbf	23/250 lbf	107/1000 lbf-in	37/500 lbf-in
US-420–740	420 lbf	840 lbf	740 lbf-in	740 lbf-in	257/2000 lbf	367/2000 lbf	427/2000 lbf-in	37/250 lbf-in
SENSING RANGES				RESOLUTION				

SI (Metric)

Calibration	Fx,Fy	Fz	Tx,Ty	Tz	Fx,Fy	Fz	Tx,Ty	Tz
SI-475–20	475 N	950 N	20 Nm	20 Nm	143/1000 N	51/250 N	13/2000 Nm	9/2000 Nm
SI-950–40	950 N	1900 N	40 Nm	40 Nm	571/2000 N	51/125 N	1/80 Nm	17/2000 Nm
SI-1900–80	1900 N	3800 N	80 Nm	80 Nm	571/1000 N	102/125 N	49/2000 Nm	17/1000 Nm
SENSING RANGES				RESOLUTION				

US (English)

Calibration	Fx,Fy	Fz	Tx,Ty, Tz	Fx,Fy	Fz	Tx,Ty, Tz
US-105–185	±55 lbf	±110 lbf	±110 lbf-in	5.5 lbf/V	11 lbf/V	11 lbf-in/V
US-210–370	±110 lbf	±220 lbf	±220 lbf-in	11 lbf/V	22 lbf/V	22 lbf-in/V
US-420–740	±220 lbf	±440 lbf	±440 lbf-in	22 lbf/V	44 lbf/V	44 lbf-in/V
Analog Output Range			Analog ±10V Sensitivity‡			

SI (Metric)

Calibration	Fx,Fy	Fz	Tx,Ty, Tz	Fx,Fy	Fz	Tx,Ty, Tz
SI-475–20	±250 N	±500 N	±12.5 Nm	25 N/V	50 N/V	1.25 Nm/V
SI-950–40	±500 N	±1000 N	±25 Nm	50 N/V	100 N/V	2.5 Nm/V
SI-1900–80	±1000 N	±2000 N	±50 Nm	100 N/V	200 N/V	5 Nm/V
Analog Output Range			Analog ±10V Sensitivity‡			

Counts Value

Calibration	Fx, Fy, Fz	Tx, Ty, Tz	Fx, Fy, Fz	Tx, Ty, Tz
US-105–185 / SI-475–20	2560 / lbf	1280 / lbf-in	576 / N	14400 / Nm
US-210–370 / SI-950–40	1280 / lbf	640 / lbf-in	288 / N	7200 / Nm
US-420–740 / SI-1900–80	640 / lbf	320 / lbf-in	144 / N	3600 / Nm
Tool Transform Factor	0.02 in/unit		0.4 mm/unit	
Counts Value – US (English)			Counts Value – SI (Metric)	

CTL resolutions are typical. System resolutions quoted are the effective resolution after dropping eight counts of noise. The effective resolution can be improved with filtering. NOTE: Applied loads must be within range in each of the six axes for the F/T sensor to measure correctly.

‡ ±5V Sensitivity values are double the listed ±10V Sensitivity values.

4.8.3 Mini85 Physical Properties
US (English)

Single-Axis Overload	
Fxy	±2800 lbf
Fz	±6100 lbf
Txy	±4400 lbf-in
Tz	±5400 lbf-in
Stiffness (Calculated)	
X-axis & Y-axis forces (Kx, Ky)	4.4x10 ⁵ lb/in
Z-axis force (Kz)	6.8x10 ⁵ lb/in
X-axis & Y-axis torque (Ktx, Kty)	7.2x10 ⁵ lbf-in/rad
Z-axis torque (Ktz)	1.2x10 ⁶ lbf-in/rad
Resonant Frequency (Measured)	
Fx, Fy, Tz	2400 Hz
Fz, Tx, Ty	3100 Hz
Physical Specifications	
Weight*	1.4 lb
Diameter*	3.4 in
Height*	1.2 in

SI (Metric)

Single-Axis Overload	
Fxy	±13000 N
Fz	±27000 N
Txy	±500 Nm
Tz	±610 Nm
Stiffness (Calculated)	
X-axis & Y-axis forces (Kx, Ky)	7.7x10 ⁷ N/m
Z-axis force (Kz)	1.2x10 ⁸ N/m
X-axis & Y-axis torque (Ktx, Kty)	8.1x10 ⁴ Nm/rad
Z-axis torque (Ktz)	1.3x10 ⁵ Nm/rad
Resonant Frequency (Measured)	
Fx, Fy, Tz	2400 Hz
Fz, Tx, Ty	3100 Hz
Physical Specifications	
Weight*	0.635 kg
Diameter*	85 mm
Height*	30 mm

* Specifications include standard interface plates.

4.8.4 Mini85 (US Calibration Complex Loading)

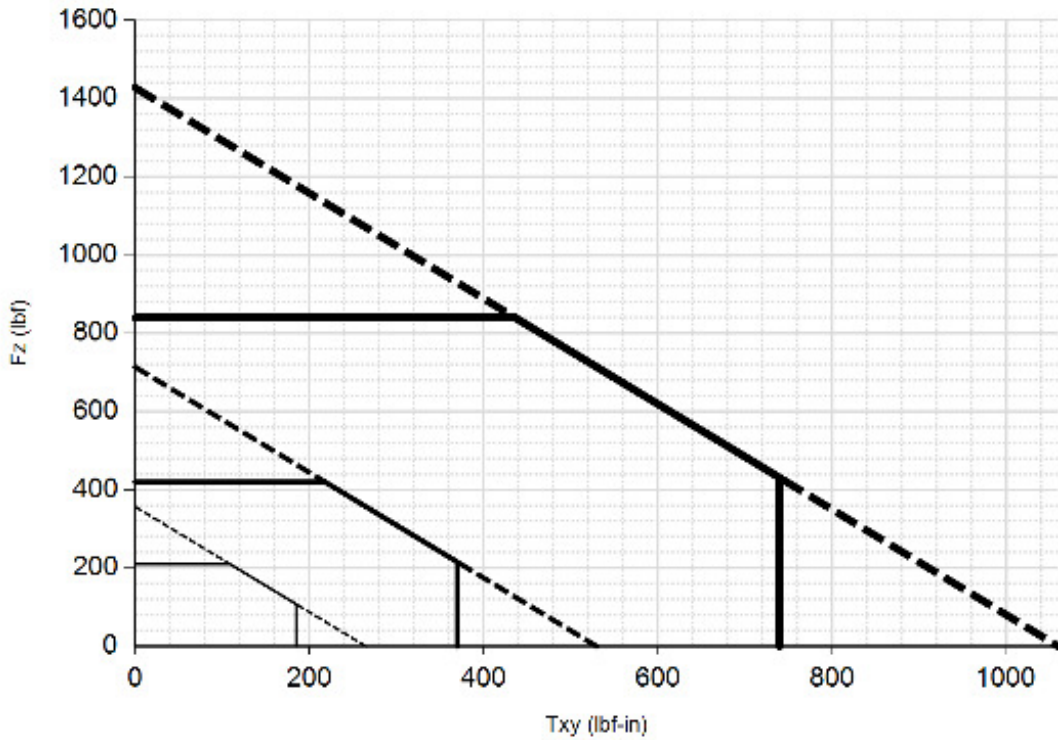
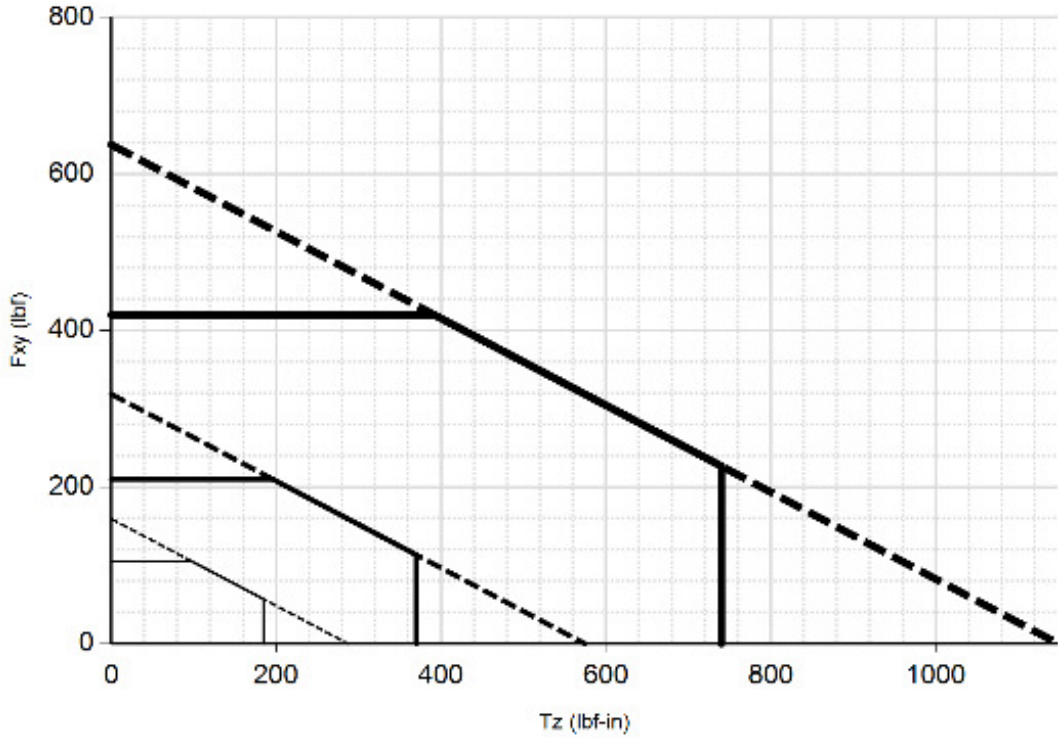

US-105-185
 US-210-370
 US-420-740

4.8.5 Mini85 (SI Calibration Complex Loading)

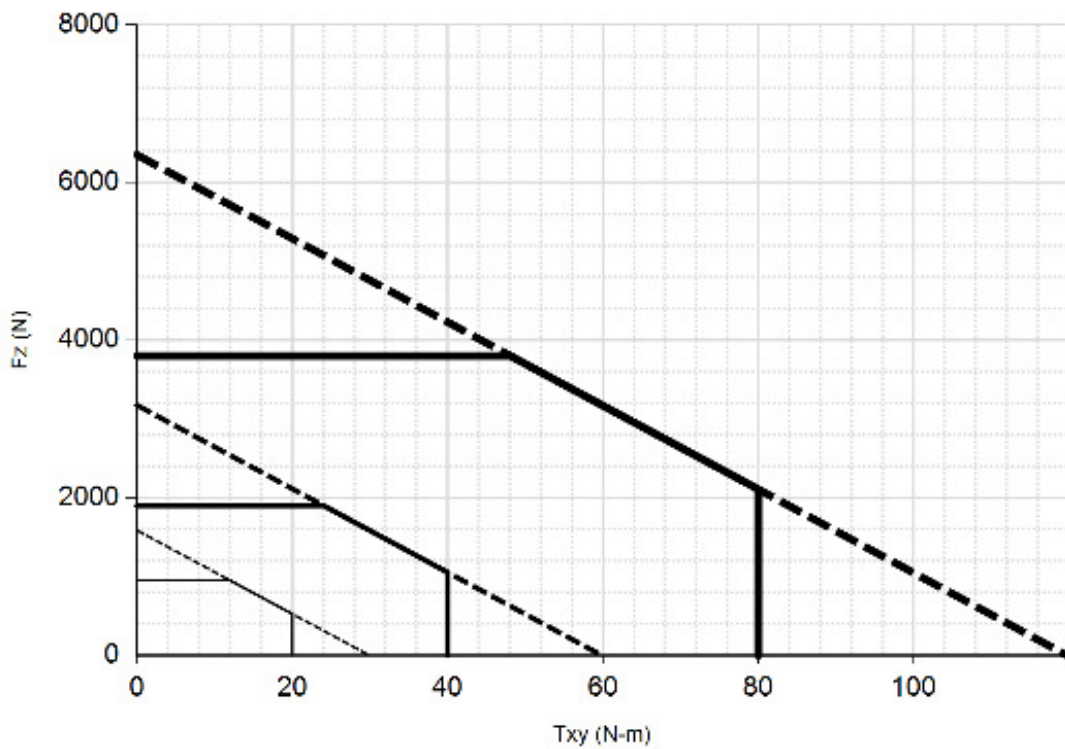
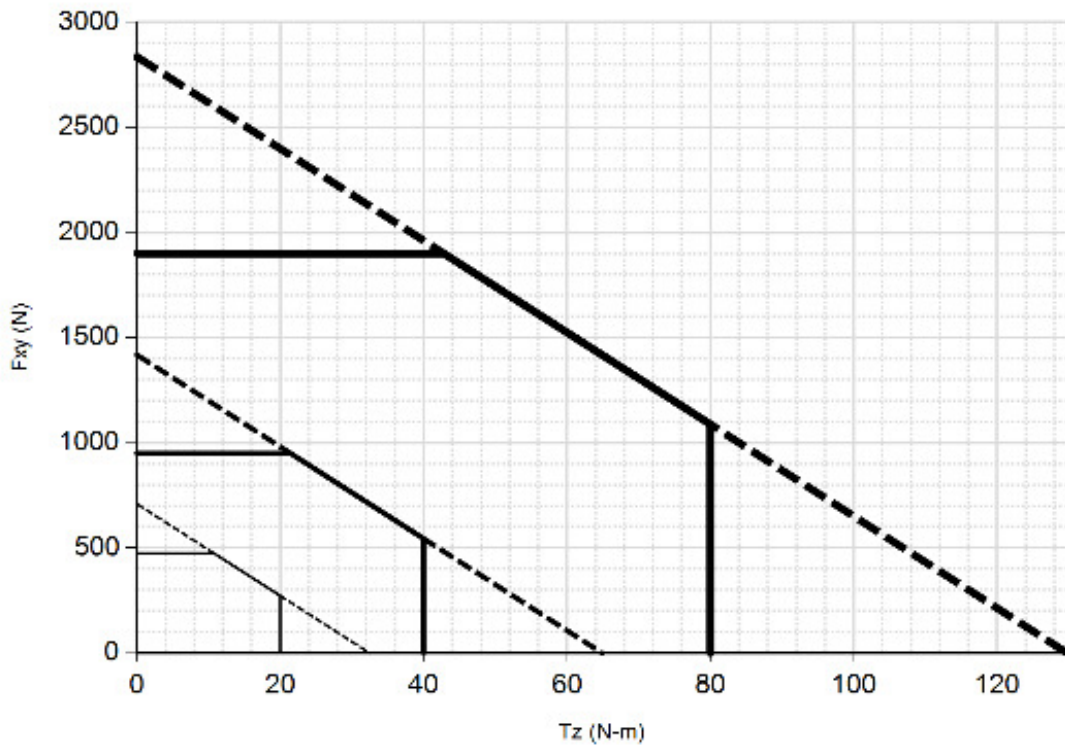

SI-475-20
 SI-950-40
 SI-1900-80

4.8.6 Mini85-E Transducer

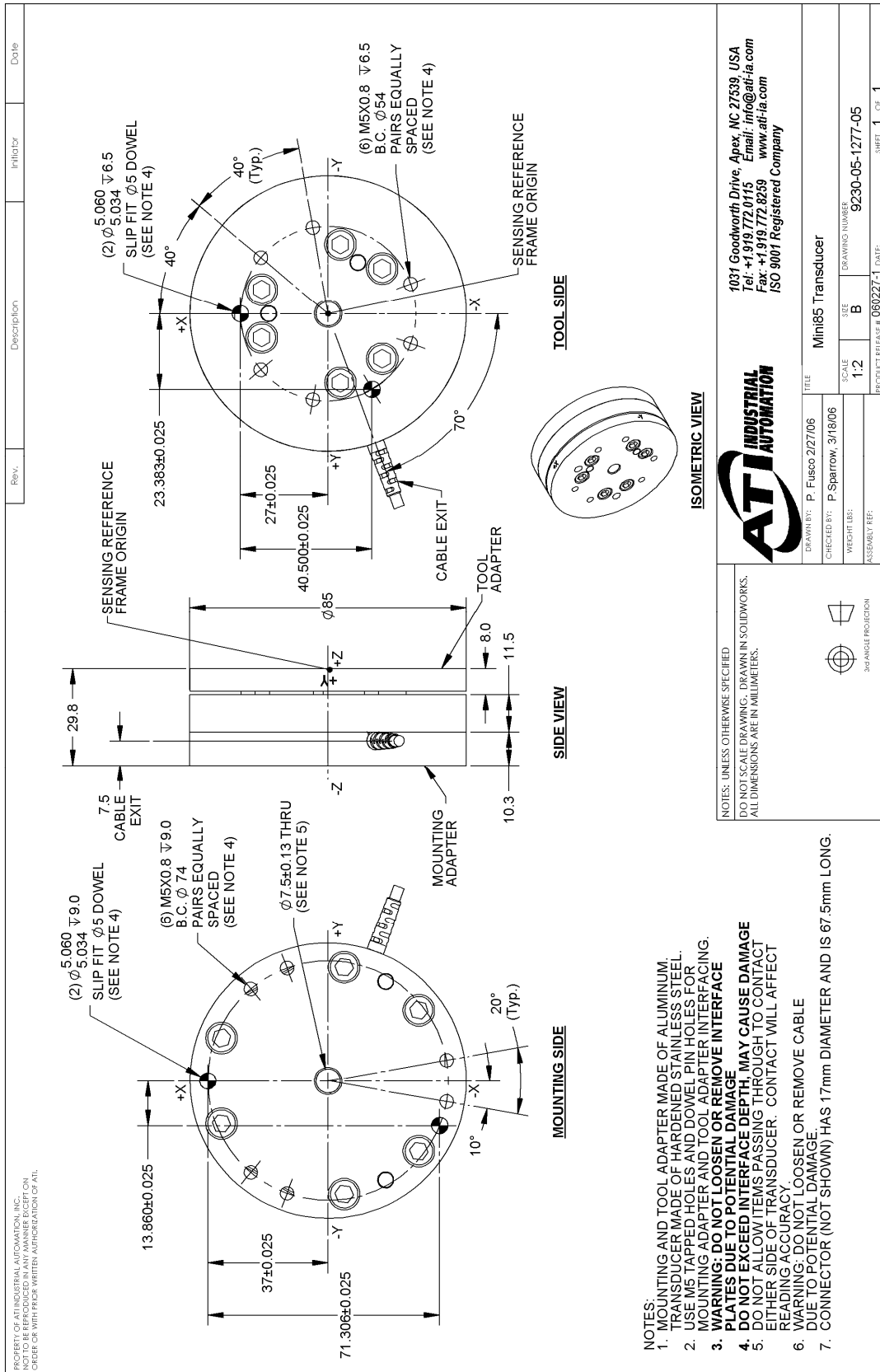

4.9 Gamma (Includes IP60/IP65 Versions)

4.9.1 Calibration Specifications (excludes CTL calibrations)

US (English)

Calibration	Fx,Fy	Fz	Tx,Ty	Tz	Fx,Fy	Fz	Tx,Ty	Tz
US-7.5–25	7.5 lbf	25 lbf	25 lbf-in	25 lbf-in	1/640 lbf	1/320 lbf	1/320 lbf-in	1/320 lbf-in
US-15–50	15 lbf	50 lbf	50 lbf-in	50 lbf-in	1/320 lbf	1/160 lbf	1/160 lbf-in	1/160 lbf-in
US-30–100	30 lbf	100 lbf	100 lbf-in	100 lbf-in	1/160 lbf	1/80 lbf	1/80 lbf-in	1/80 lbf-in
	SENSING RANGES				RESOLUTION*			

SI (Metric)

Calibration	Fx,Fy	Fz	Tx,Ty	Tz	Fx,Fy	Fz	Tx,Ty	Tz
SI-32–2.5	32 N	100 N	2.5 Nm	2.5 Nm	1/160 N	1/80 N	1/2000 Nm	1/2000 Nm
SI-65–5	65 N	200 N	5 Nm	5 Nm	1/80 N	1/40 N	10/13333 Nm	10/13333 Nm
SI-130–10	130 N	400 N	10 Nm	10 Nm	1/40 N	1/20 N	1/800 Nm	1/800 Nm
	SENSING RANGES				RESOLUTION*			

* DAQ resolutions are typical for a 16-bit data acquisition system.

These system resolutions quoted are the effective resolution after dropping four counts of noise. The effective resolution can be improved with filtering. NOTE: Applied loads must be within range in each of the six axes for the F/T sensor to measure correctly.

4.9.2 CTL Calibration Specifications

US (English)

Calibration	Fx,Fy	Fz	Tx,Ty	Tz	Fx,Fy	Fz	Tx,Ty	Tz
US-7.5–25	7.5 lbf	25 lbf	25 lbf-in	25 lbf-in	1/320 lbf	1/160 lbf	1/160 lbf-in	1/160 lbf-in
US-15–50	15 lbf	50 lbf	50 lbf-in	50 lbf-in	1/160 lbf	1/80 lbf	1/80 lbf-in	1/80 lbf-in
US-30–100	30 lbf	100 lbf	100 lbf-in	100 lbf-in	1/80 lbf	1/40 lbf	1/40 lbf-in	1/40 lbf-in

SI (Metric)

SI-32–2.5	32 N	100 N	2.5 Nm	2.5 Nm	1/80 N	1/40 N	1/1000 Nm	1/1000 Nm
SI-65–5	65 N	200 N	5 Nm	5 Nm	1/40 N	1/20 N	5/3333 Nm	5/3333 Nm
SI-130–10	130 N	400 N	10 Nm	10 Nm	1/20 N	1/10 N	1/400 Nm	1/400 Nm
SENSING RANGES				RESOLUTION				

US (English)

Calibration	Fx,Fy	Fz†	Tx,Ty, Tz	Fx,Fy	Fz†	Tx,Ty, Tz
US-7.5–25	±7.5 lbf	±25 lbf	±25 lbf-in	0.75 lbf/V	2.5 lbf/V	2.5 lbf-in/V
US-15–50	±15 lbf	±50 lbf	±50 lbf-in	1.5 lbf/V	5 lbf/V	5 lbf-in/V
US-30–100	±30 lbf	±100 lbf	±100 lbf-in	3 lbf/V	10 lbf/V	10 lbf-in/V

SI (Metric)

SI-32–2.5	±32 N	±100 N	±2.5 Nm	3.2 N/V	10 N/V	0.25 Nm/V
SI-65–5	±65 N	±200 N	±5 Nm	6.5 N/V	20 N/V	0.5 Nm/V
SI-130–10	±130 N	±400 N	±10 Nm	13 N/V	40 N/V	1 Nm/V
Analog Output Range			Analog ±10V Sensitivity‡			

Counts Value

Calibration	Fx, Fy, Fz	Tx, Ty, Tz	Fx, Fy, Fz	Tx, Ty, Tz
US-7.5–25 / SI-32–2.5	2560 / lbf	2560 / lbf-in	640 / N	8000 / Nm
US-15–50 / SI-65–5	1280 / lbf	1280 / lbf-in	320 / N	5333.33 / Nm
US-30–100 / SI-130–10	640 / lbf	640 / lbf-in	160 / N	3200 / Nm
Tool Transform Factor	See Tool Transform Factor table			
Counts Value – US (English)		Counts Value – SI (Metric)		

Tool Transform Factor

Calibration	US (English)	SI (Metric)
SI-1000–120	0.01 in/unit	0.8 mm/unit
SI-1500–240	0.01 in/unit	0.6 mm/unit
SI-2500–400	0.01 in/unit	0.5 mm/unit

CTL resolutions are typical. System resolutions quoted are the effective resolution after dropping eight counts of noise. The effective resolution can be improved with filtering. NOTE: Applied loads must be within range in each of the six axes for the F/T sensor to measure correctly.

† For IP68 version see caution on physical properties page.

‡ ±5V Sensitivity values are double the listed ±10V Sensitivity values.

4.9.3 Gamma Physical Properties
US (English)

Single-Axis Overload	
Fxy	±280 lbf
Fz	±930 lbf
Txy	±700 lbf-in
Tz	±730 lbf-in
Stiffness (Calculated)	
X-axis & Y-axis forces (Kx, Ky)	5.2x10 ⁴ lb/in
Z-axis force (Kz)	1.0x10 ⁵ lb/in
X-axis & Y-axis torque (Ktx, Kty)	9.3x10 ⁴ lbf-in/rad
Z-axis torque (Ktz)	1.4x10 ⁵ lbf-in/rad
Resonant Frequency (Measured)	
Fx, Fy, Tz	1400 Hz
Fz, Tx, Ty	2000 Hz
Physical Specifications	
Weight*	0.562 lb
Diameter*	3 in
Height*	1.3 in

SI (Metric)

Single-Axis Overload	
Fxy	±1200 N
Fz	±4100 N
Txy	±79 Nm
Tz	±82 Nm
Stiffness (Calculated)	
X-axis & Y-axis forces (Kx, Ky)	9.1x10 ⁶ N/m
Z-axis force (Kz)	1.8x10 ⁷ N/m
X-axis & Y-axis torque (Ktx, Kty)	1.1x10 ⁴ Nm/rad
Z-axis torque (Ktz)	1.6x10 ⁴ Nm/rad
Resonant Frequency (Measured)	
Fx, Fy, Tz	1400 Hz
Fz, Tx, Ty	2000 Hz
Physical Specifications	
Weight*	0.255 kg
Diameter*	75 mm
Height*	33 mm

* Specifications include standard interface plates.

**4.9.4 Gamma (US Calibration Complex Loading)
 (Includes IP60/IP65 Version)**

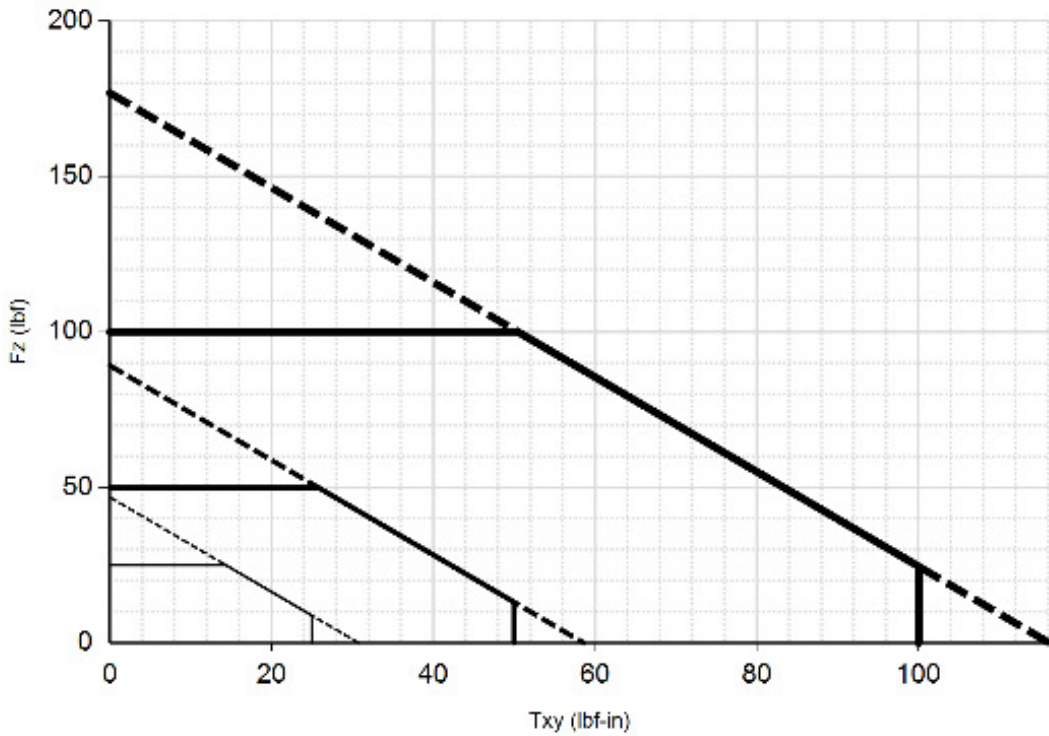
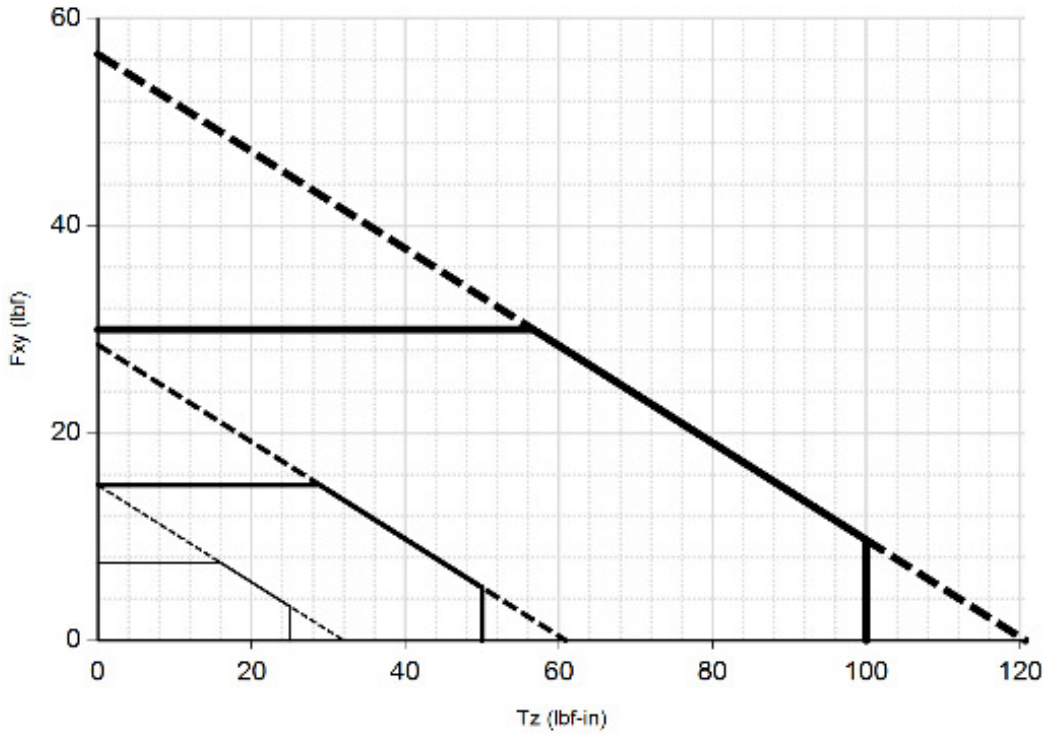

US-7.5-25
 US-15-50
 US-30-100

**4.9.5 Gamma (SI Calibration Complex Loading)
 (Includes IP60/IP65 Version)**

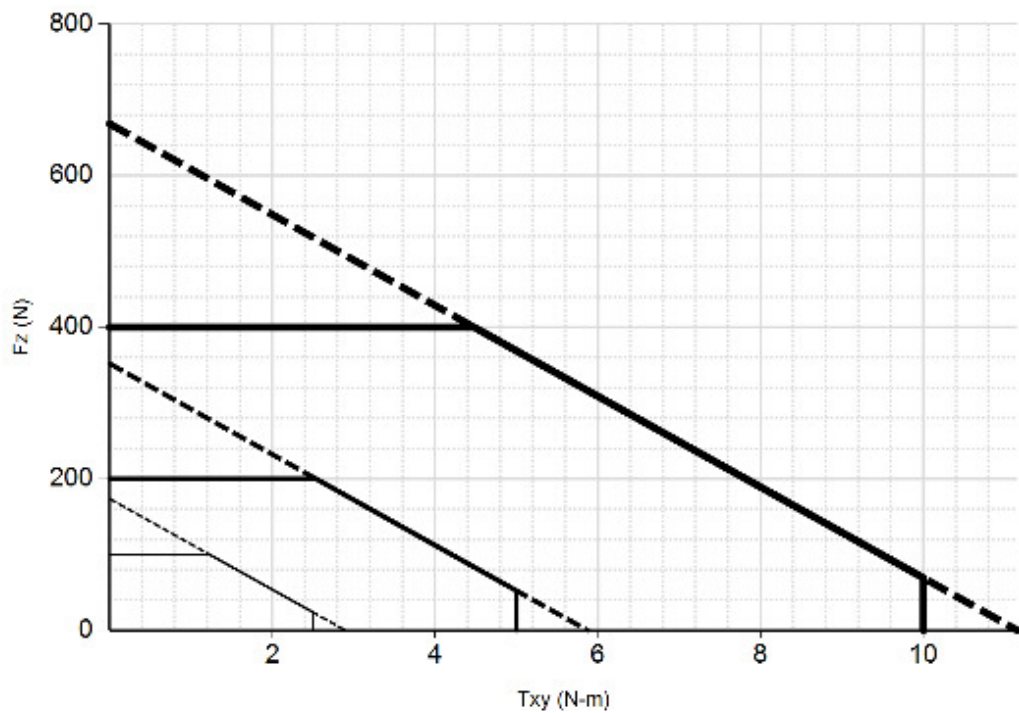
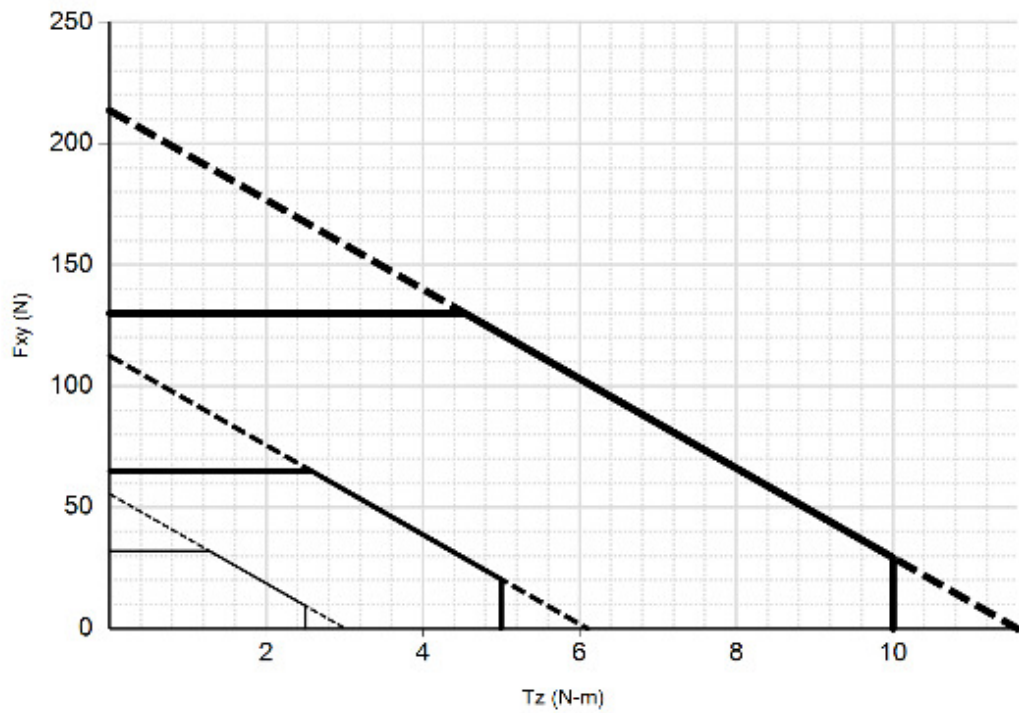

— SI-32-2.5
— SI-65-5
— SI-130-10

4.9.6 Gamma DAQ/Net Transducer

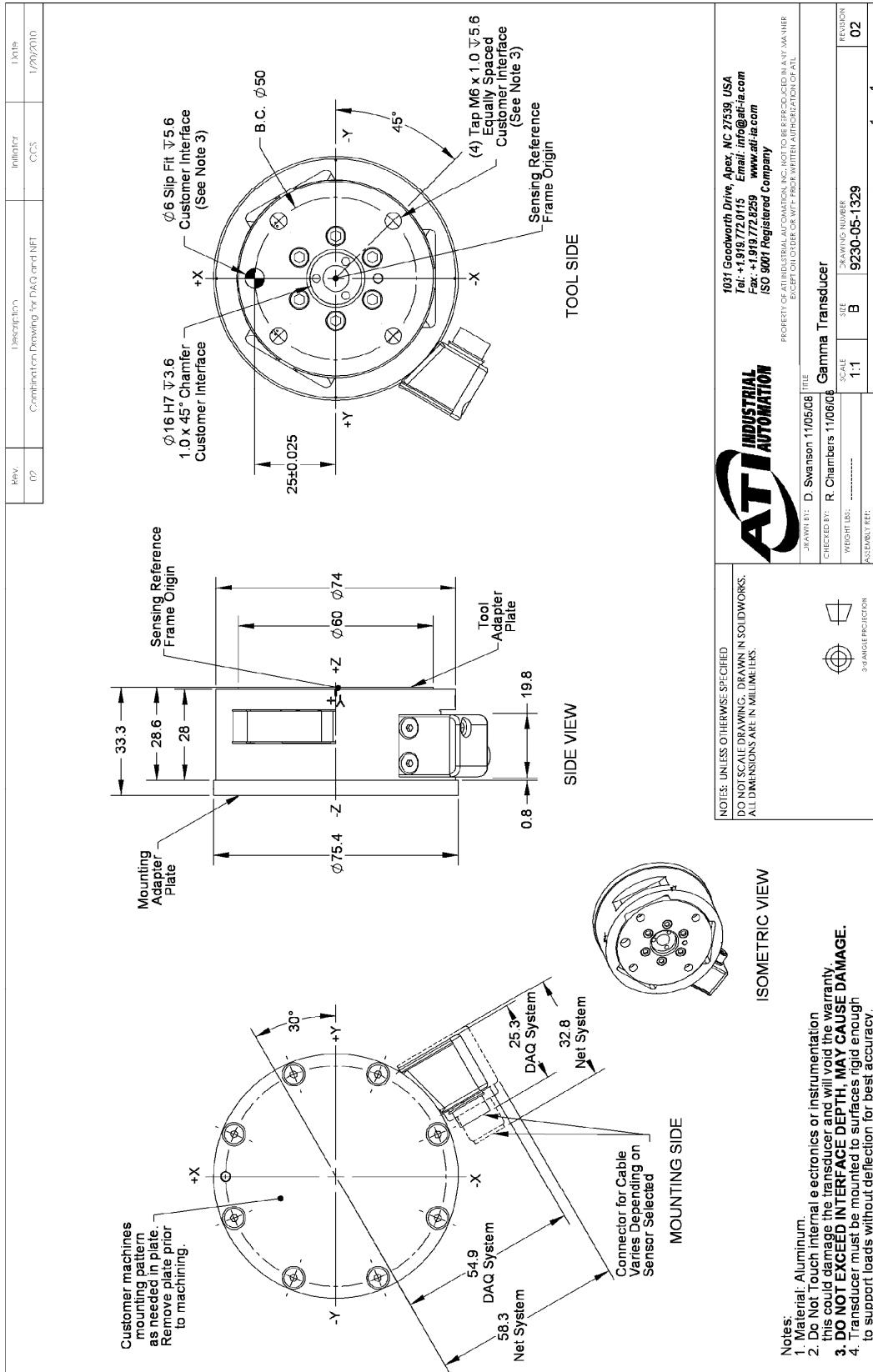

4.9.7 9105-T-Gamma Transducer without Mounting Adapter

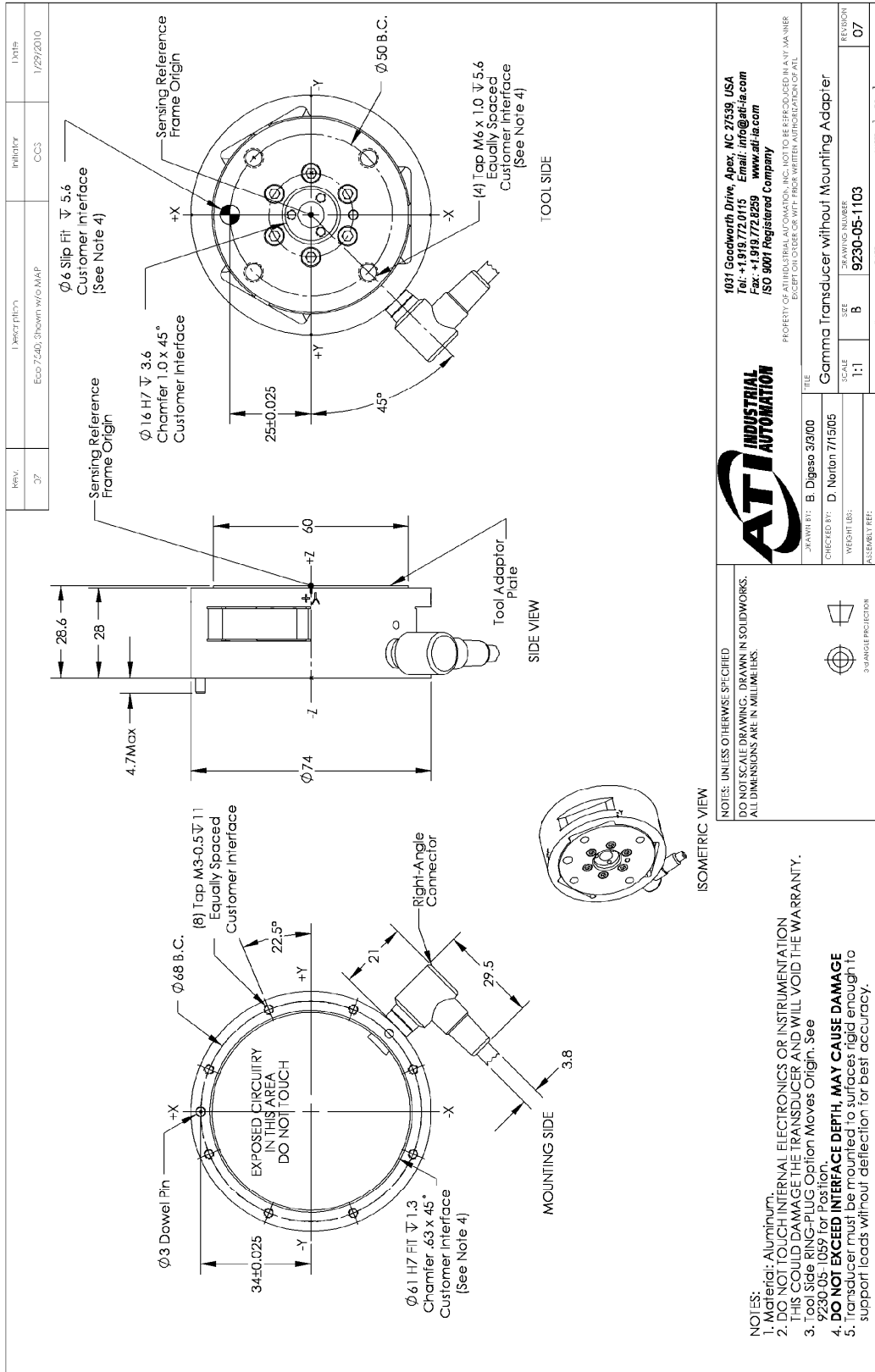

Note: Mux transducers are used in F/T Controller systems.

4.9.8 Gamma Mounting Adapter Plate

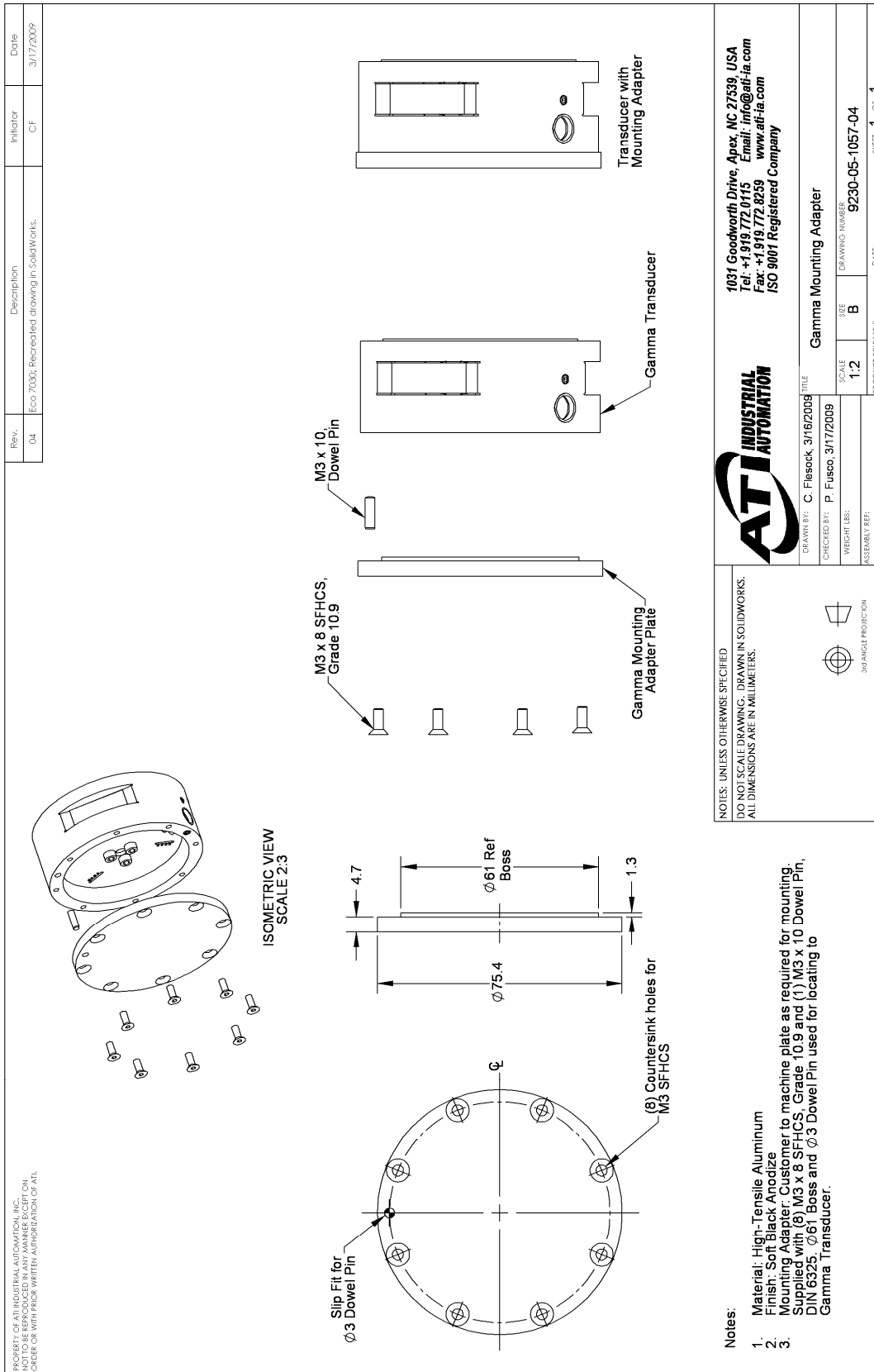

4.9.9 Gamma Tool Ring-plug Adaptor

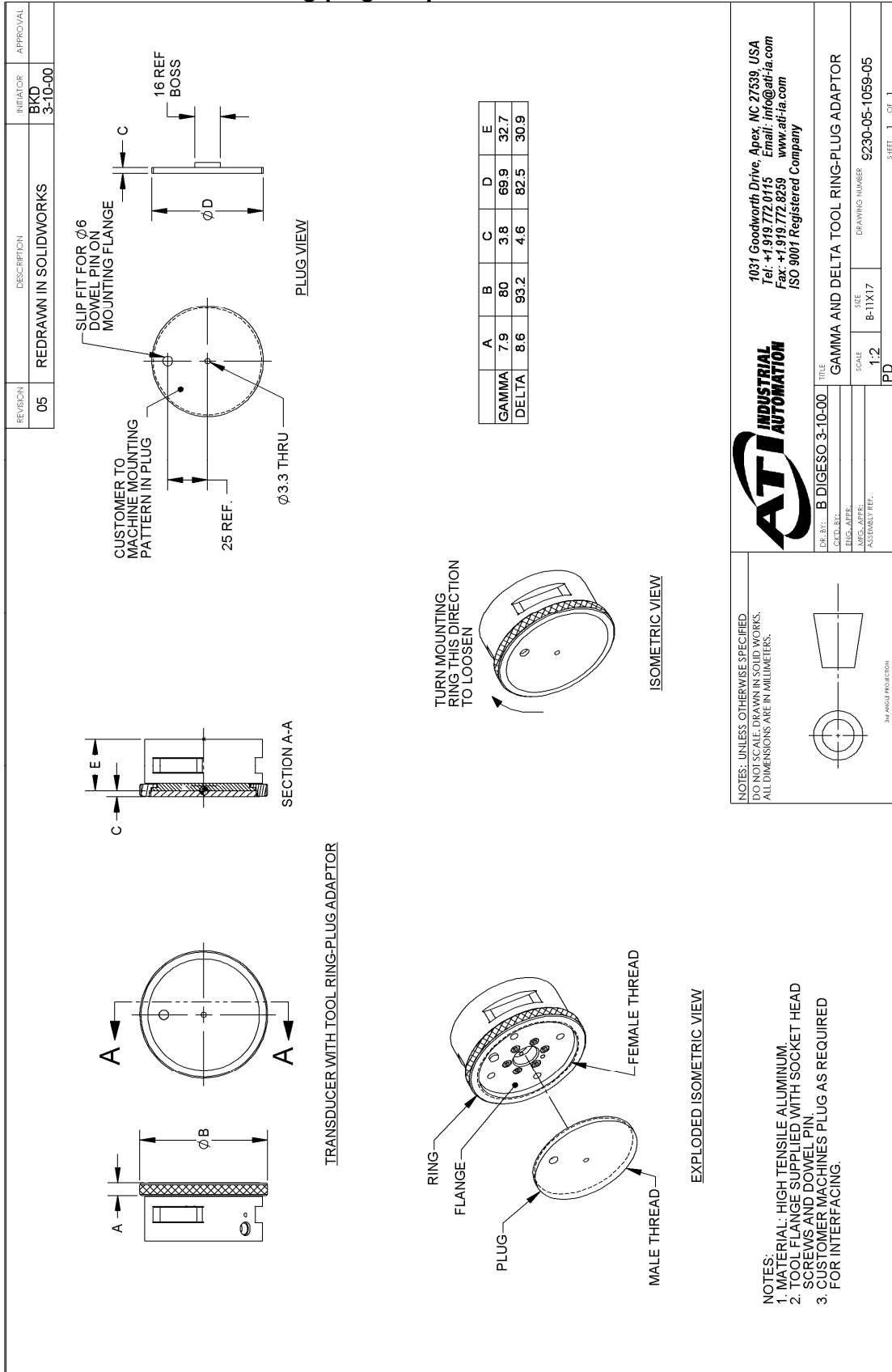

4.9.10 Gamma IP60 Transducer

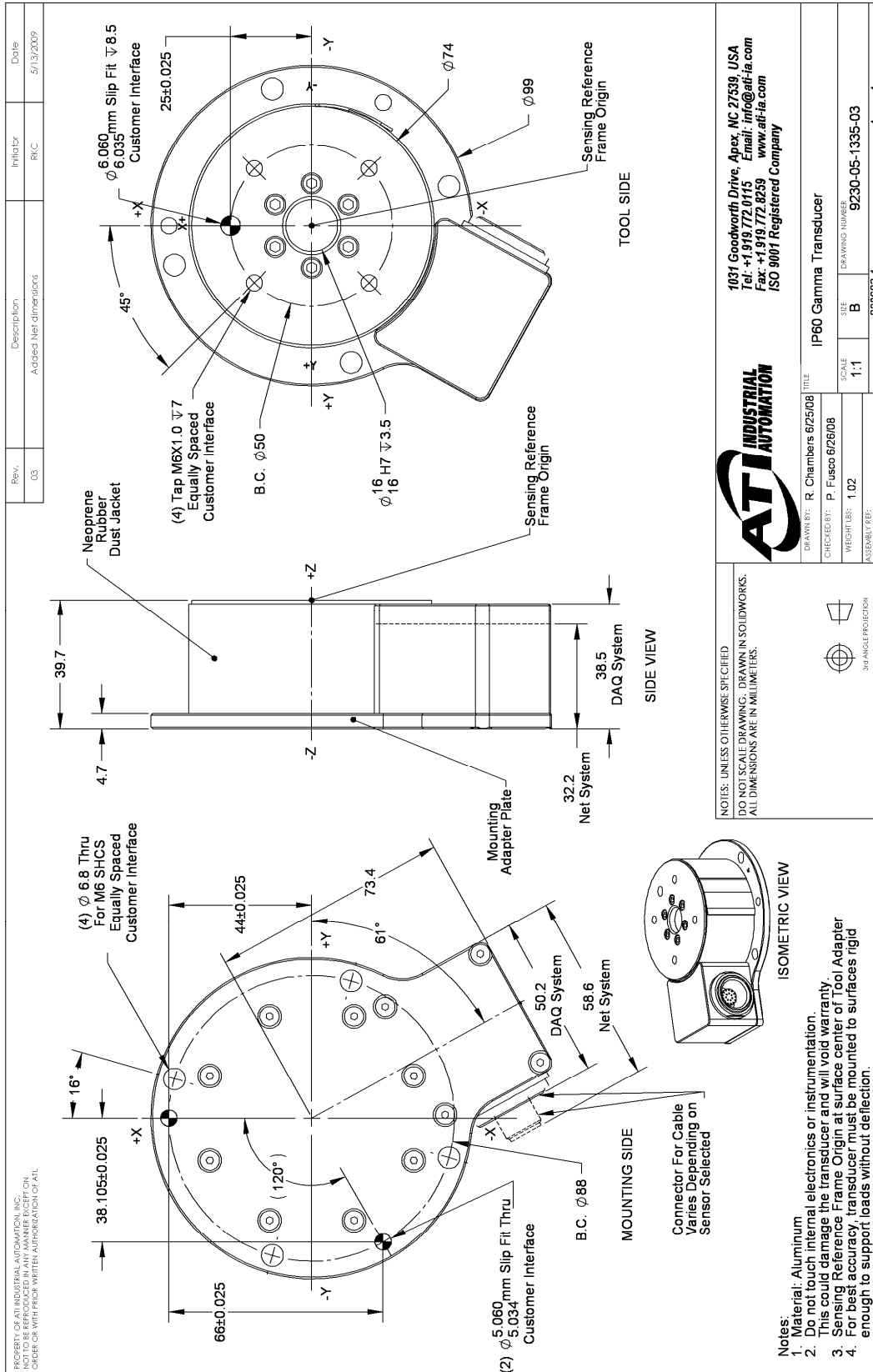

4.9.11 Gamma Mounting Ring-plug Adapter

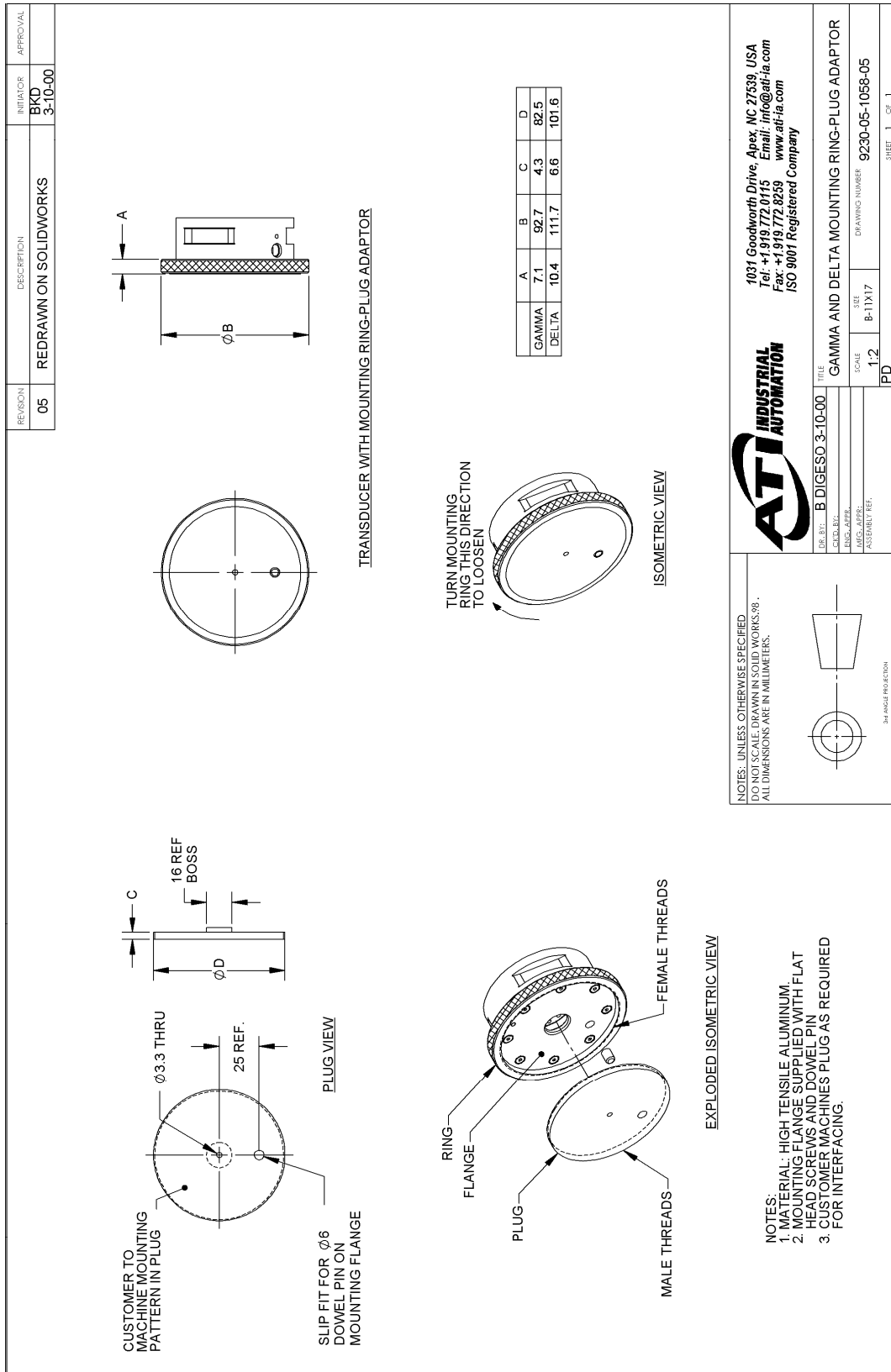

4.9.12 Gamma IP65 Transducer

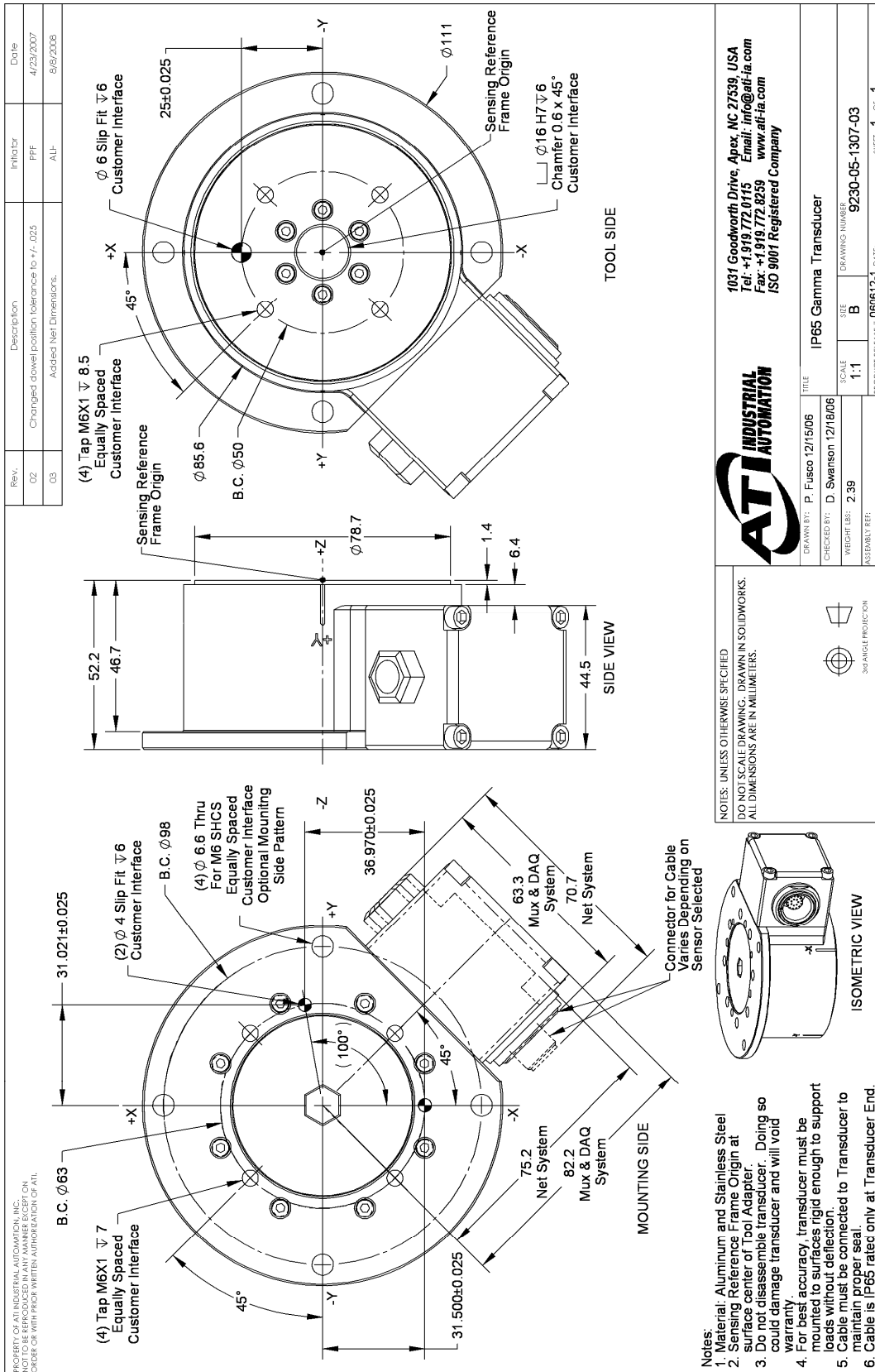

Rev.	Description	Initiator	Date
02	Changed dowel position tolerance to +/- .025	PFJ	4/23/2007
03	Added Net Dimensions.	ALI	8/6/2008

		1031 Goodworth Drive, Apex, NC 27539, USA Tel: +1.919.772.0115 Email: info@ati-ia.com Fax: +1.919.772.8259 www.ati-ia.com ISO 9001 Registered Company	
		TITLE: IP65 Gamma Transducer	
DRAWN BY: P. Fusco 12/15/06	CHECKED BY: D. Swanson 12/18/06	SCALE: 1:1	DRAWING NUMBER: 9230-05-1307-03
WEIGHT LBS: 2.39	ASSEMBLY REF:	PRODUCT RELEASE #: 060612-1	DATE:
			SHEET 1 OF 1

NOTES: UNLESS OTHERWISE SPECIFIED
 DO NOT SCALE DRAWING. DRAWN IN SOLIDWORKS.
 ALL DIMENSIONS ARE IN MILLIMETERS.

4.10 Delta (Includes IP60/IP65/IP68 Versions)

4.10.1 Calibration Specifications (excludes CTL calibrations)

US (English)

Calibration	Fx,Fy	Fz***	Tx,Ty	Tz	Fx,Fy	Fz***	Tx,Ty	Tz
US-50–150	50 lbf	150 lbf	150 lbf-in	150 lbf-in	1/128 lbf	1/64 lbf	3/128 lbf-in	1/64 lbf-in
US-75–300	75 lbf	225 lbf	300 lbf-in	300 lbf-in	1/64 lbf	1/32 lbf	3/64 lbf-in	1/32 lbf-in
US-150–600	150 lbf	450 lbf	600 lbf-in	600 lbf-in	1/32 lbf	1/16 lbf	3/32 lbf-in	1/16 lbf-in
	SENSING RANGES				RESOLUTION*			

SI (Metric)

Calibration	Fx,Fy	Fz***	Tx,Ty	Tz	Fx,Fy	Fz***	Tx,Ty	Tz
SI-165–15	165 N	495 N	15 Nm	15 Nm	1/32 N	1/16 N	1/528 Nm	1/528 Nm
SI-330–30	330 N	990 N	30 Nm	30 Nm	1/16 N	1/8 N	5/1333 Nm	5/1333 Nm
SI-660–60	660 N	1980 N	60 Nm	60 Nm	1/8 N	1/4 N	10/1333 Nm	10/1333 Nm
	SENSING RANGES				RESOLUTION*			

* DAQ resolutions are typical for a 16-bit data acquisition system.

These system resolutions quoted are the effective resolution after dropping four counts of noise. The effective resolution can be improved with filtering. NOTE: Applied loads must be within range in each of the six axes for the F/T sensor to measure correctly.

4.10.2 CTL Calibration Specifications

US (English)

Calibration	Fx,Fy	Fz†	Tx,Ty	Tz	Fx,Fy	Fz†	Tx,Ty	Tz
US-50–150	50 lbf	150 lbf	150 lbf-in	150 lbf-in	1/64 lbf	1/32 lbf	3/64 lbf-in	1/32 lbf-in
US-75–300	75 lbf	225 lbf	300 lbf-in	300 lbf-in	1/32 lbf	1/16 lbf	3/32 lbf-in	1/16 lbf-in
US-150–600	150 lbf	450 lbf	600 lbf-in	600 lbf-in	1/16 lbf	1/8 lbf	3/16 lbf-in	1/8 lbf-in
SENSING RANGES				RESOLUTION				

SI (Metric)

Calibration	Fx,Fy	Fz†	Tx,Ty	Tz	Fx,Fy	Fz†	Tx,Ty	Tz
SI-165–15	165 N	495 N	15 Nm	15 Nm	1/16 N	1/8 N	1/264 Nm	1/264 Nm
SI-330–30	330 N	990 N	30 Nm	30 Nm	1/8 N	1/4 N	10/1333 Nm	10/1333 Nm
SI-660–60	660 N	1980 N	60 Nm	60 Nm	1/4 N	1/2 N	5/333 Nm	5/333 Nm
SENSING RANGES				RESOLUTION				

US (English)

Calibration	Fx,Fy	Fz†	Tx,Ty, Tz	Fx,Fy	Fz†	Tx,Ty, Tz
US-50–150	±50 lbf	±150 lbf	±150 lbf-in	5 lbf/V	15 lbf/V	15 lbf-in/V
US-75–300	±75 lbf	±225 lbf	±300 lbf-in	7.5 lbf/V	22.5 lbf/V	30 lbf-in/V
US-150–600	±150 lbf	±450 lbf	±600 lbf-in	15 lbf/V	45 lbf/V	60 lbf-in/V
Analog Output Range			Analog ±10V Sensitivity‡			

SI (Metric)

Calibration	Fx,Fy	Fz†	Tx,Ty, Tz	Fx,Fy	Fz†	Tx,Ty, Tz
SI-165–15	±165 N	±495 N	±15 Nm	16.5 N/V	49.5 N/V	1.5 Nm/V
SI-330–30	±330 N	±990 N	±30 Nm	33 N/V	99 N/V	3 Nm/V
SI-660–60	±660 N	±1980 N	±60 Nm	66 N/V	198 N/V	6 Nm/V
Analog Output Range			Analog ±10V Sensitivity‡			

Counts Value

Calibration	Fx, Fy, Fz	Tx, Ty, Tz	Fx, Fy, Fz	Tx, Ty, Tz
US-50–150 / si-165–15	512 / lbf	512 / lbf-in	128 / N	2112 / Nm
US-75–300 / SI-330–30	256 / lbf	256 / lbf-in	64 / N	1066.67 / Nm
US-150–600 / SI-660–60	128 / lbf	128 / lbf-in	32 / N	533.333 / Nm
Tool Transform Factor	0.01 in/unit		0.6 mm/unit	
Counts Value – US (English)			Counts Value – SI (Metric)	

CTL resolutions are typical. System resolutions quoted are the effective resolution after dropping eight counts of noise. The effective resolution can be improved with filtering. NOTE: Applied loads must be within range in each of the six axes for the F/T sensor to measure correctly.

† For IP68 version see caution on physical properties page.

‡ ±5V Sensitivity values are double the listed ±10V Sensitivity values.

**4.10.3 Delta Physical Properties (Includes IP60/IP65/IP68 Versions)
US (English)**

Single-Axis Overload	
Fxy	±580 lbf
Fz	±1900 lbf
Txy	±2500 lbf-in
Tz	±3600 lbf-in
Stiffness (Calculated)	
X-axis & Y-axis forces (Kx, Ky)	2.0x10 ⁵ lb/in
Z-axis force (Kz)	3.4x10 ⁵ lb/in
X-axis & Y-axis torque (Ktx, Kty)	4.6x10 ⁵ lbf-in/rad
Z-axis torque (Ktz)	8.1x10 ⁵ lbf-in/rad
Resonant Frequency (Measured)	
Fx, Fy, Tz	1500 Hz
Fz, Tx, Ty	1700 Hz
Physical Specifications	
Weight*	2.01 lb
Diameter*	3.7 in
Height*	1.3 in

SI (Metric)

Single-Axis Overload	
Fxy	±2600 N
Fz	±8600 N
Txy	±290 Nm
Tz	±400 Nm
Stiffness (Calculated)	
X-axis & Y-axis forces (Kx, Ky)	3.6x10 ⁷ N/m
Z-axis force (Kz)	5.9x10 ⁷ N/m
X-axis & Y-axis torque (Ktx, Kty)	5.2x10 ⁴ Nm/rad
Z-axis torque (Ktz)	9.1x10 ⁴ Nm/rad
Resonant Frequency (Measured)	
Fx, Fy, Tz	1500 Hz
Fz, Tx, Ty	1700 Hz
Physical Specifications	
Weight*	0.913 kg
Diameter*	94 mm
Height*	33 mm

* Specifications include standard interface plates.



CAUTION:

IP68 Delta Fz as a Function of Submersion Depth:

When submerged, IP68 transducers exhibit a decrease in Fz range related to the submersion depth. This loss is the result of pressure-induced preloading on the transducer. The preload can be masked by biasing the transducer at the depth prior to applying the load to be measured. The following estimates are for room temperature fresh water at seal level.

IP68 Delta	US	Metric
Fz preload at 10m depth	-161 lb	-716 N
Fz preload at other depths	-4.9 lb/ft × depthInFeet	-72 N/m × depthInMeters

**4.10.4 Delta (US Calibration Complex Loading)
 (Includes IP60/IP65/IP68 Versions)**

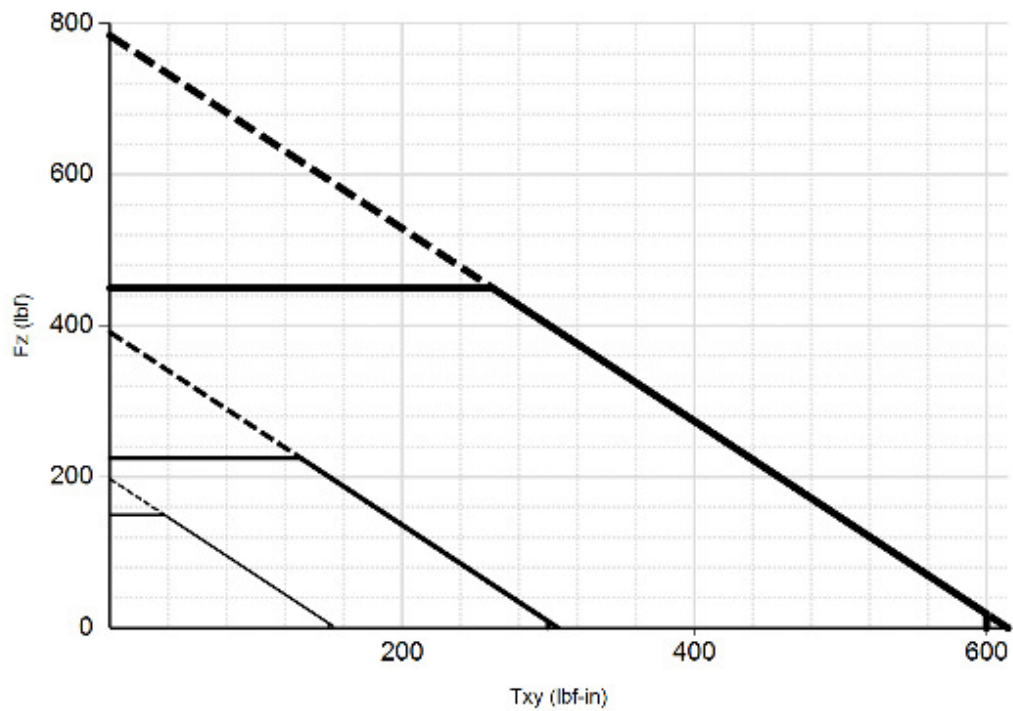
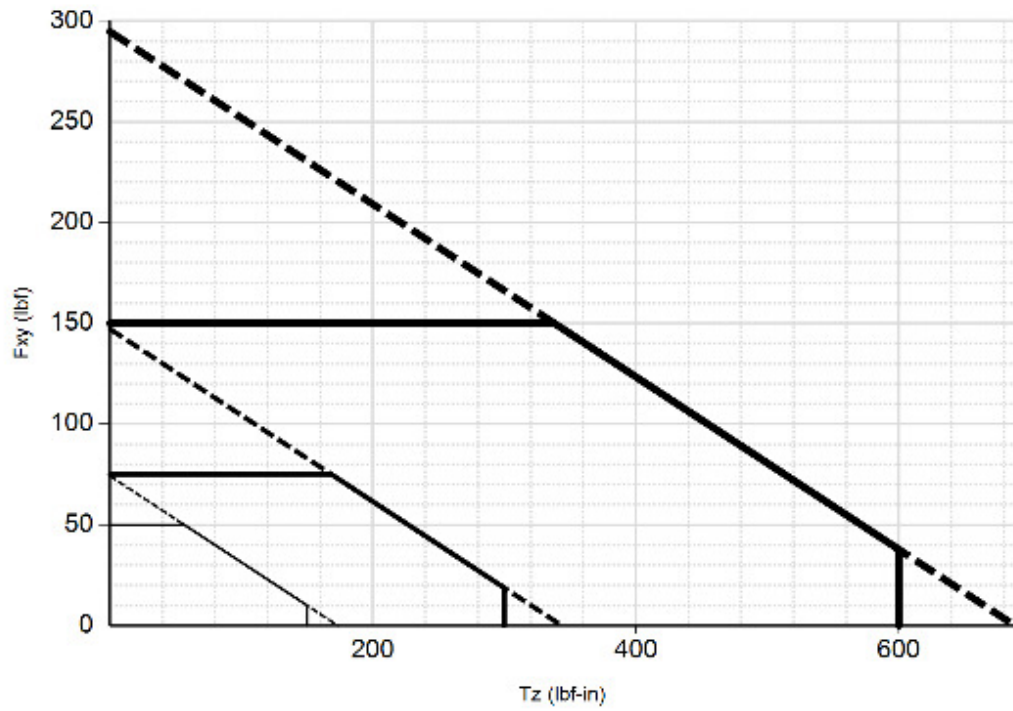

US-50-150
 US-75-300
 US-150-600

*** For IP68 version see caution on physical properties page.

**4.10.5 Delta (SI Calibration Complex Loading)
 (Includes IP60/IP65/IP68 Versions)**

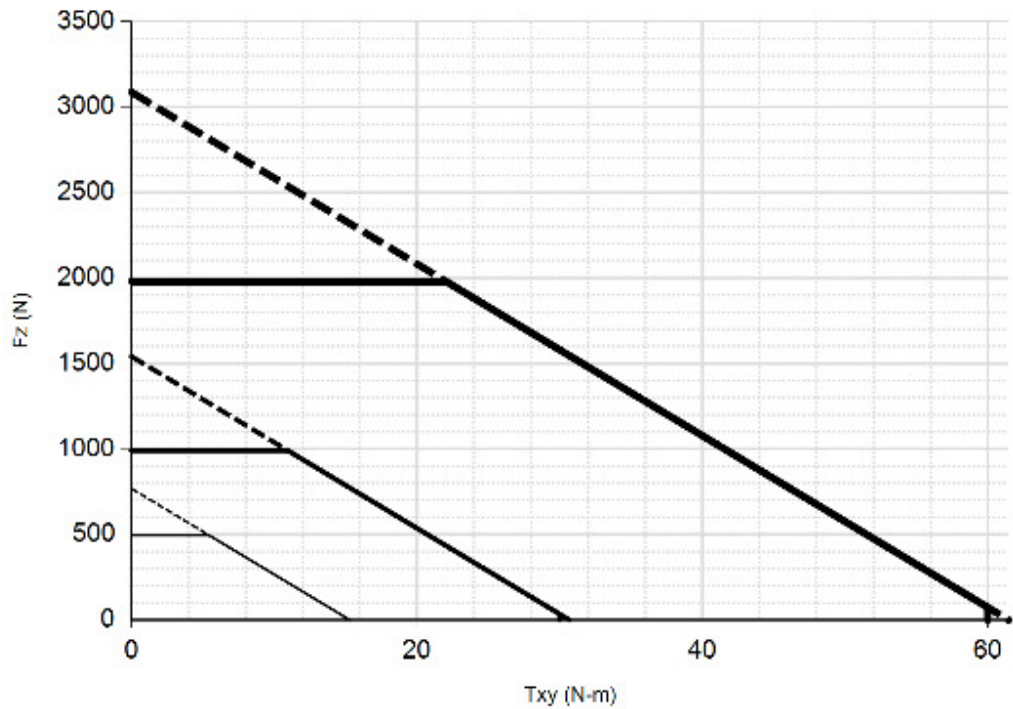
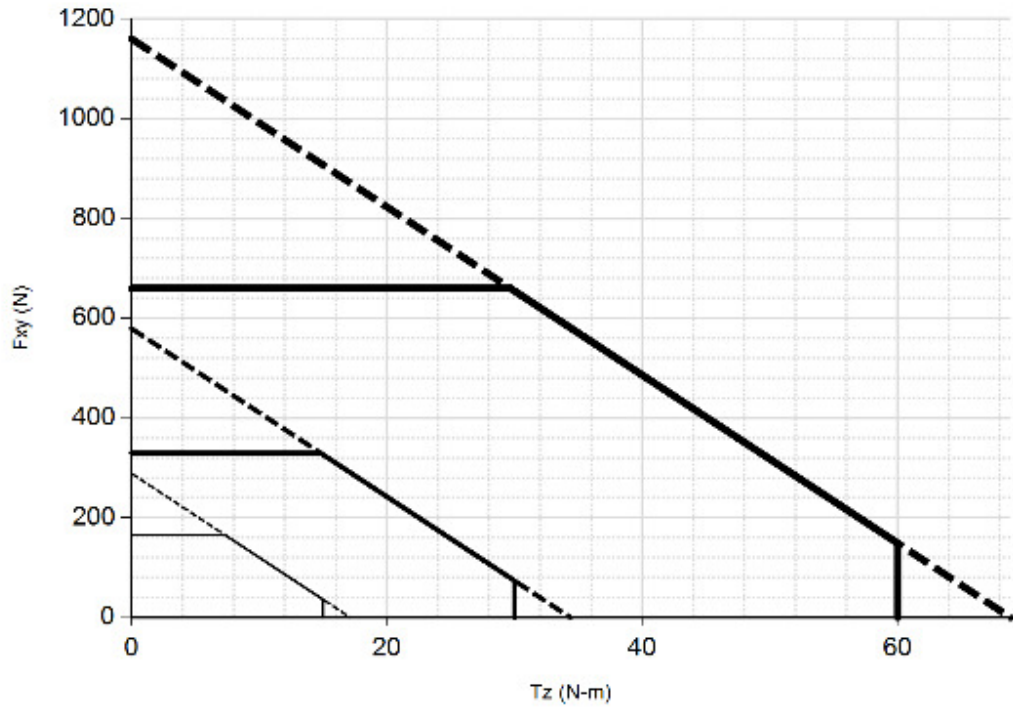

— SI-165-15 — SI-330-30 — SI-660-60

*** For IP68 version see caution on physical properties page.

4.10.6 Delta DAQ/Net Transducer

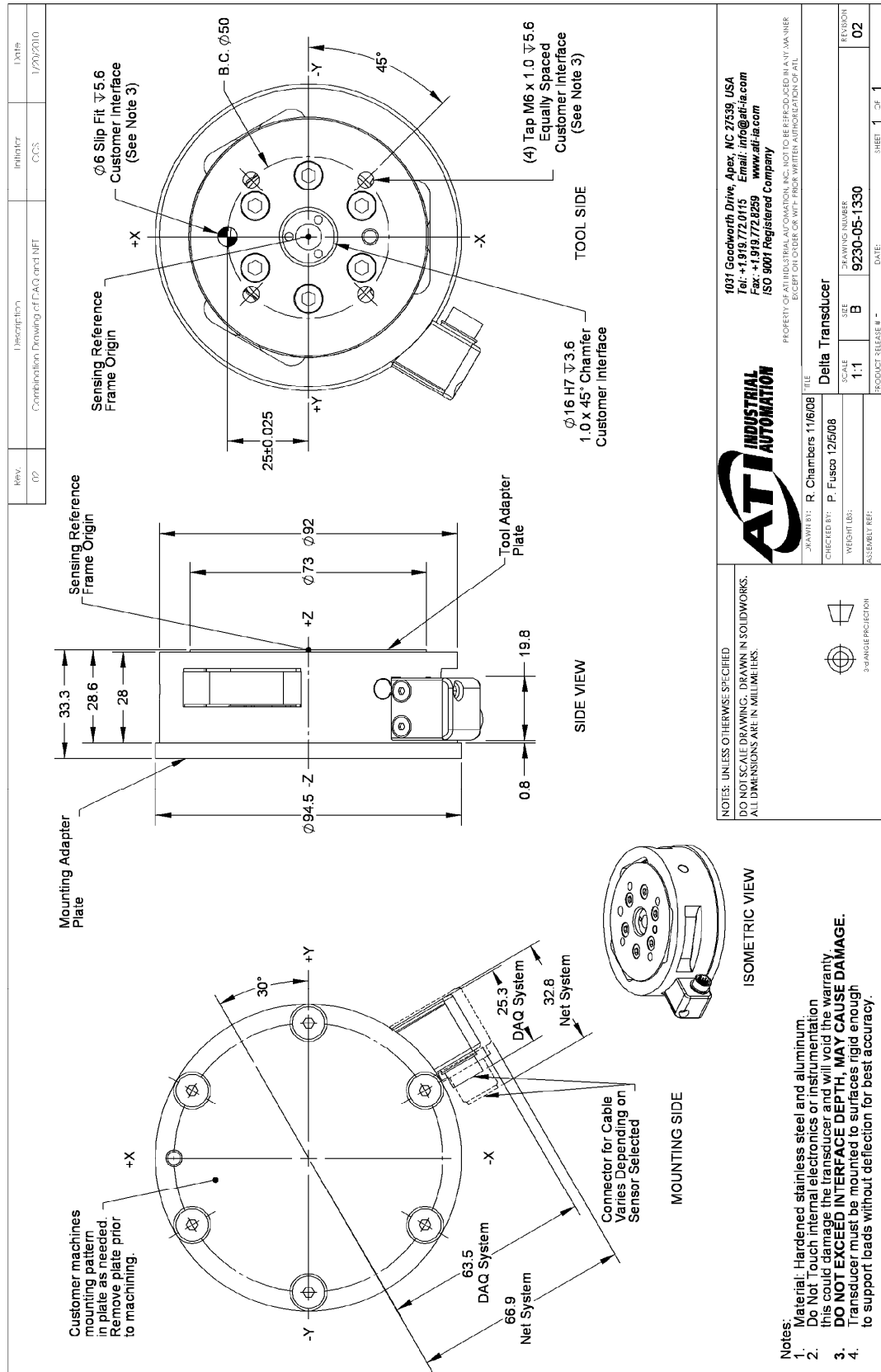

ATI INDUSTRIAL AUTOMATION

1031 Goodworth Drive, Apex, NC 27539, USA
 Tel: +1.919.772.0115 Email: info@ati-ia.com
 Fax: +1.919.772.8259 www.ati-ia.com
 ISO 9001 Registered Company

PROPERTY OF ATI INDUSTRIAL AUTOMATION, INC. NOT TO BE REPRODUCED IN ANY MANNER EXCEPT ON ORDER OR WITH EXPRESS WRITTEN AUTHORIZATION OF ATI.

TITLE: Delta Transducer
 DRAWING NUMBER: 9230-05-1330
 SCALE: 1:1
 SIZE: B

DESIGNED BY: R. Chambers 11/6/08
 CHECKED BY: P. Fusco 12/5/08

WEIGHT: LBS.
 ASSEMBLY REF.

PRODUCT RELEASE # -
 DATE: SHEET 1 OF 1

NOTES: UNLESS OTHERWISE SPECIFIED DO NOT SCALE DRAWING. DRAWN IN SOLIDWORKS. ALL DIMENSIONS ARE IN MILLIMETERS.

3 ANGLE PROJECTION

4.10.7 9105-T-Delta Transducer without Mounting Adapter

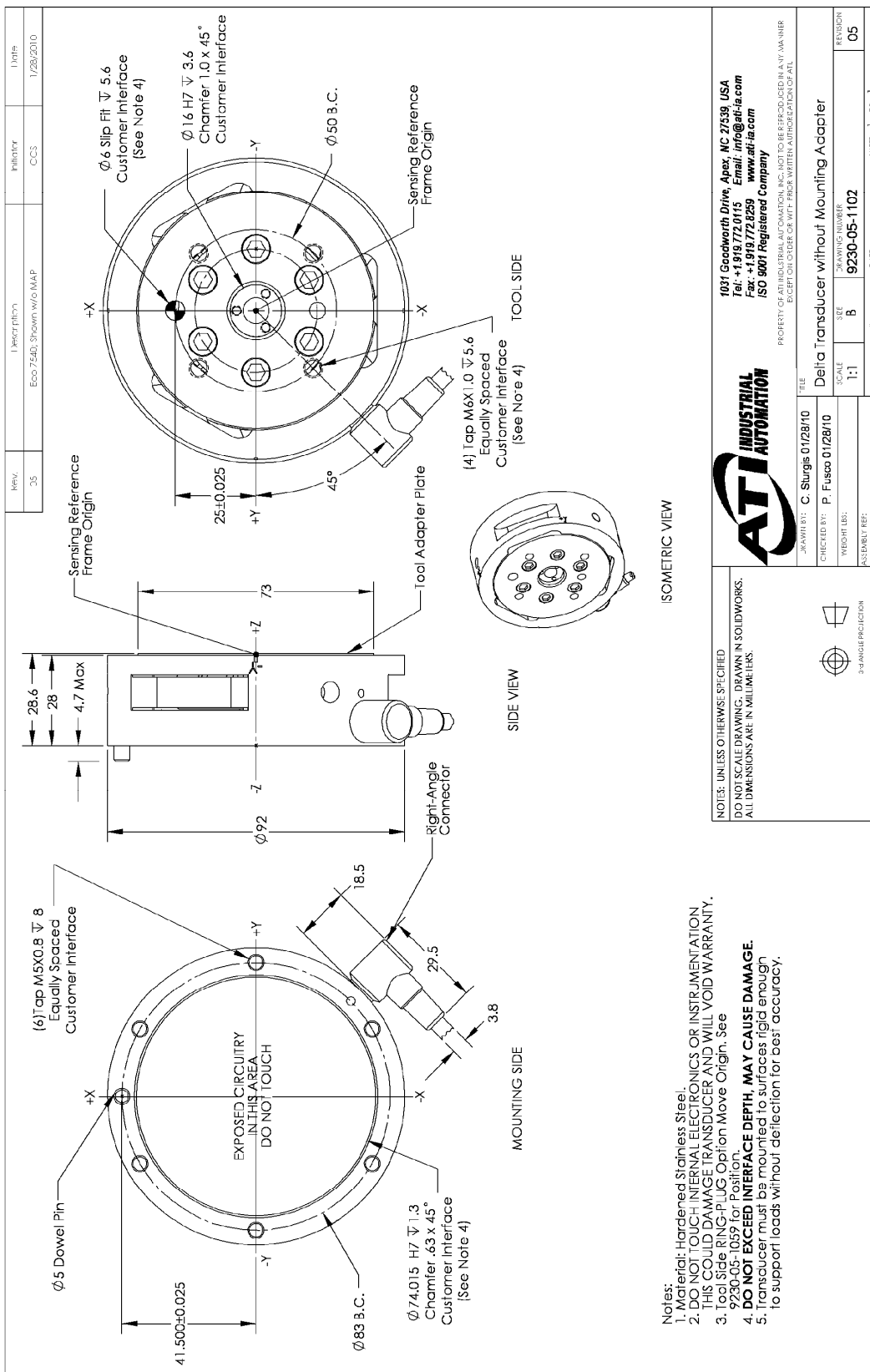

Note: Mux transducers are used in F/T Controller systems.

4.10.8 Delta Mounting Adapter

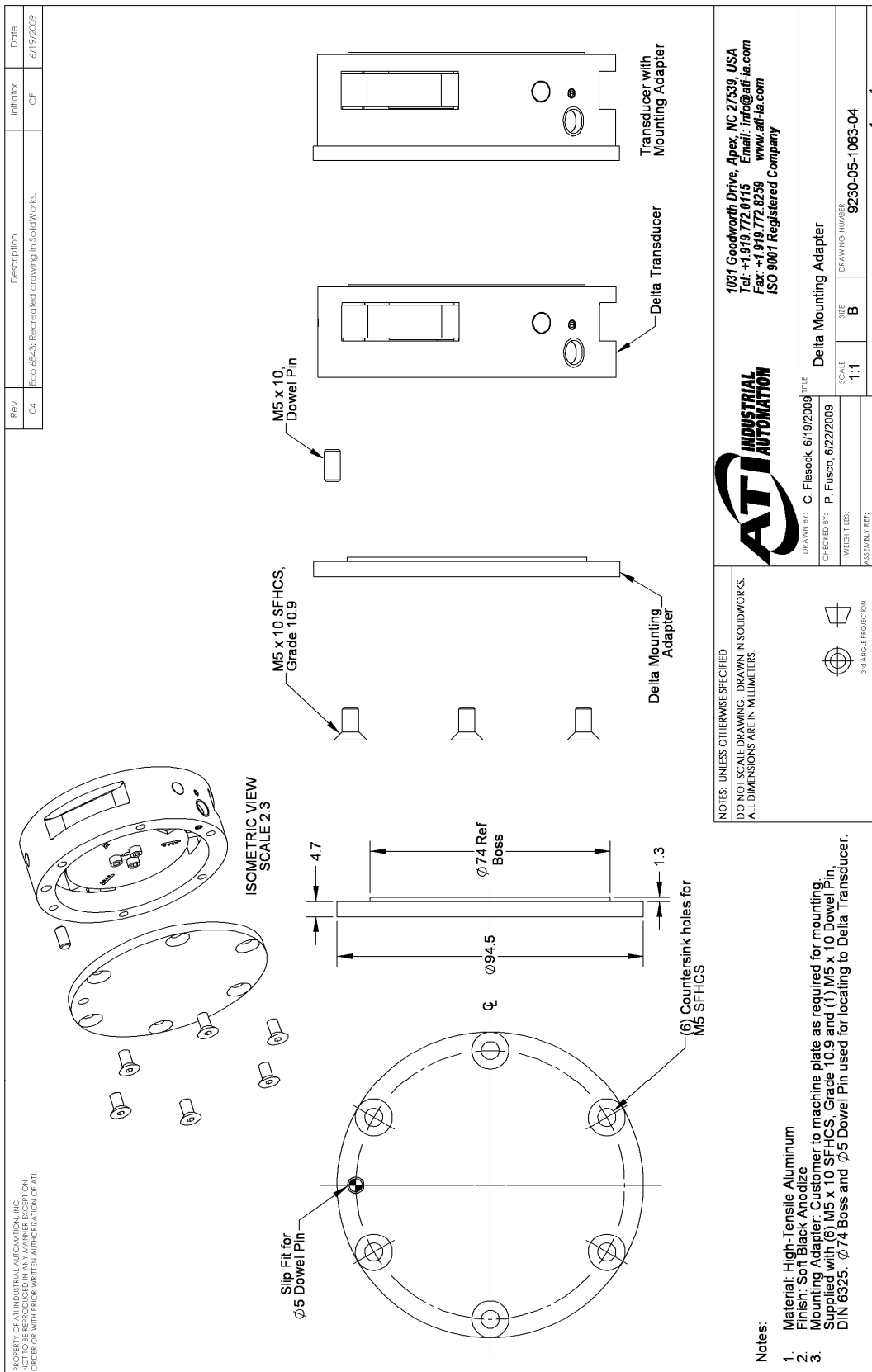

4.10.9 Delta Tool Ring-plug Adapter

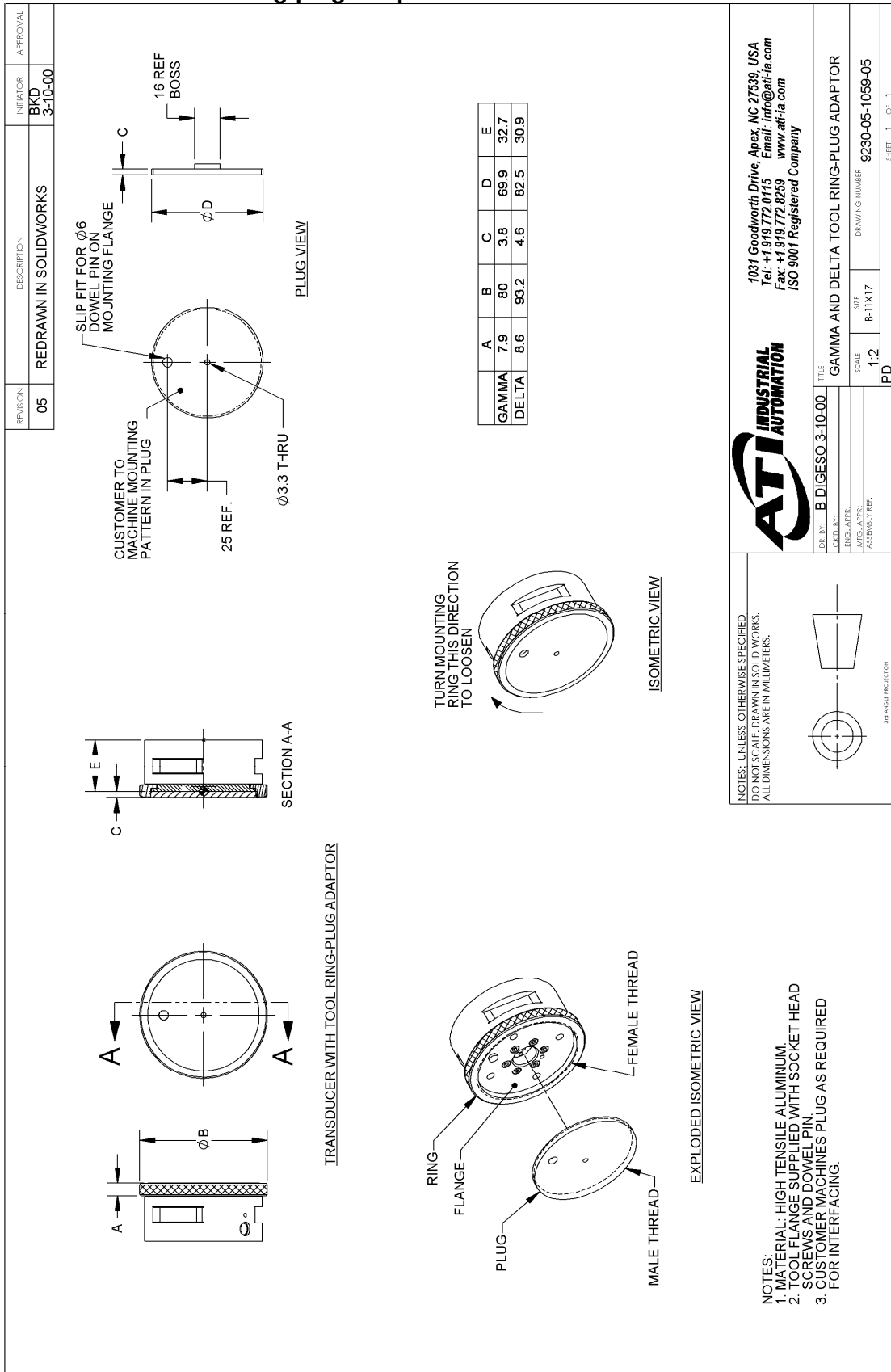

4.10.10 Delta Mounting Ring-plug Adapter

REVISION 05	DESCRIPTION REDRAWN ON SOLIDWORKS	INITIATOR BKD 3-10-00	APPROVAL
----------------	--------------------------------------	-----------------------------	----------

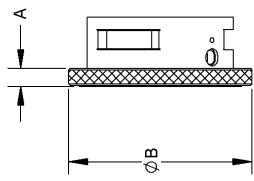

TRANSUCER WITH MOUNTING RING-PLUG ADAPTOR

	A	B	C	D
GAMMA	7.1	92.7	4.3	82.5
DELTA	10.4	111.7	6.6	101.6

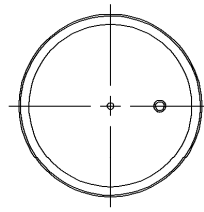

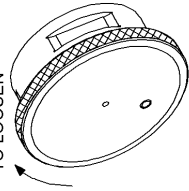

ISOMETRIC VIEW

TURN MOUNTING RING THIS DIRECTION TO LOOSEN

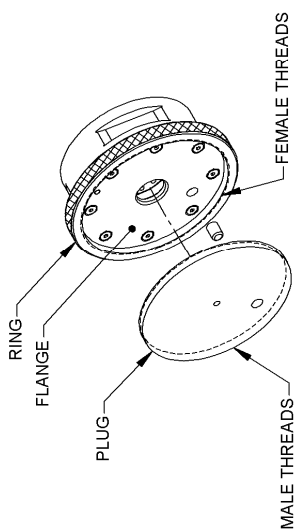

EXPLODED ISOMETRIC VIEW

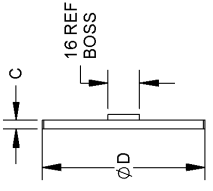

PLUG VIEW

CUSTOMER TO MACHINE MOUNTING PATTERN IN PLUG

SLIP FIT FOR $\phi 6$ DOWEL PIN ON MOUNTING FLANGE

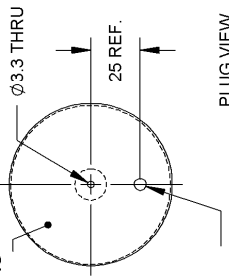

PLUG VIEW

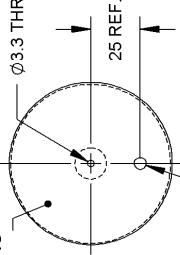

PLUG VIEW

NOTES: UNLESS OTHERWISE SPECIFIED
 DO NOT SCALE: DRAWN IN SOLID WORKS 98.
 ALL DIMENSIONS ARE IN MILLIMETERS.

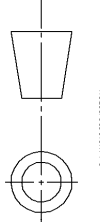

3rd ANGLE PROJECTION

1031 Goodworth Drive, Apex, NC 27539 USA
 Tel: +1 919 772 0115 Email: info@ati-ia.com
 Fax: +1 919 772 8259 www.ati-ia.com
 ISO 9001 Registered Company



DR. BY: B DIGESO 3-10-00	TITLE: GAMMA AND DELTA MOUNTING RING-PLUG ADAPTOR	SCALE: 1:2	DRAWING NUMBER: 9230-05-1058-05
DATE: 8-11X17	SIZE: 8-11X17	SHEET 1 OF 1	

4.10.11 Delta IP60 Transducer

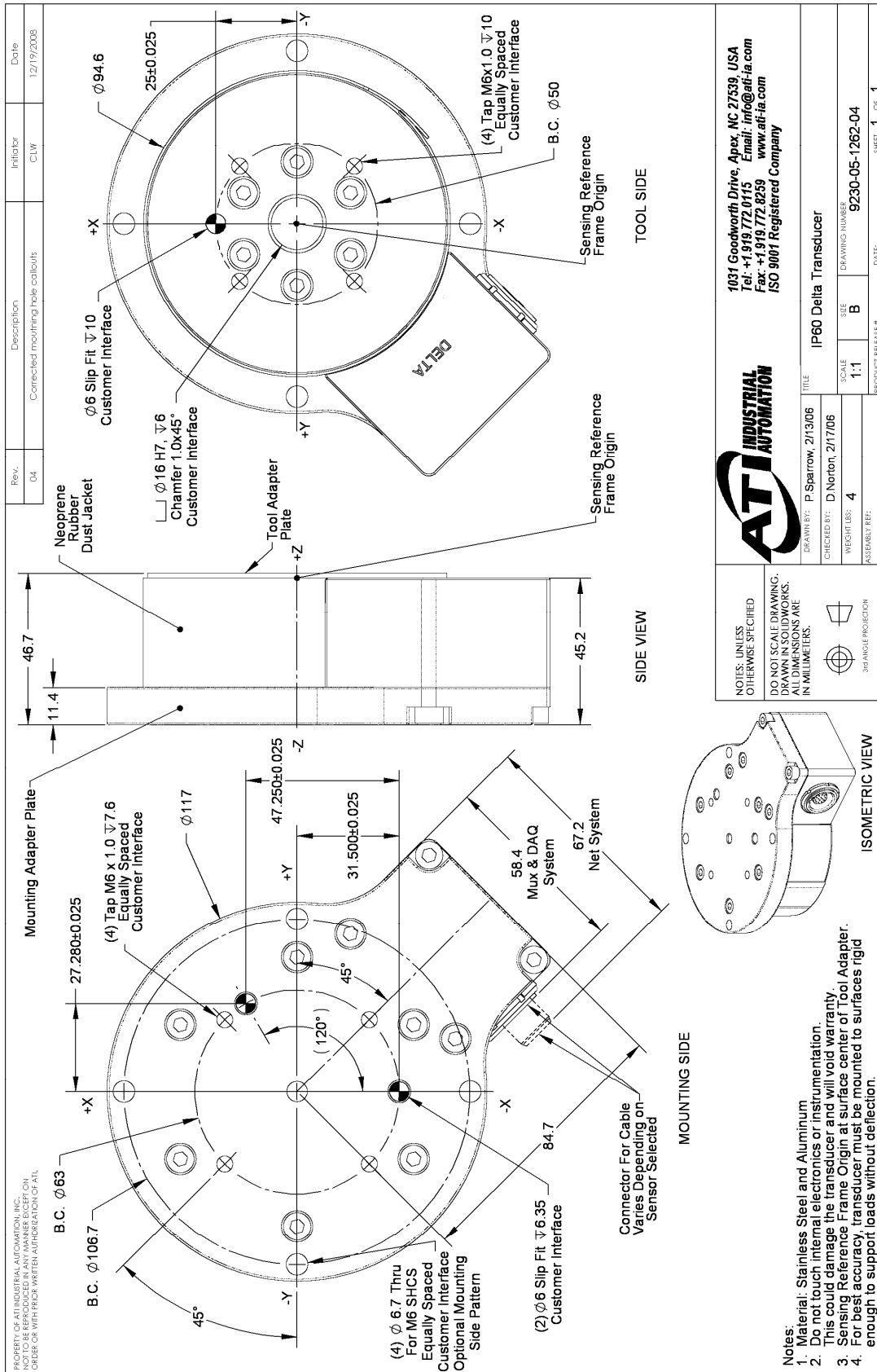

4.10.12 Delta IP65 Transducer

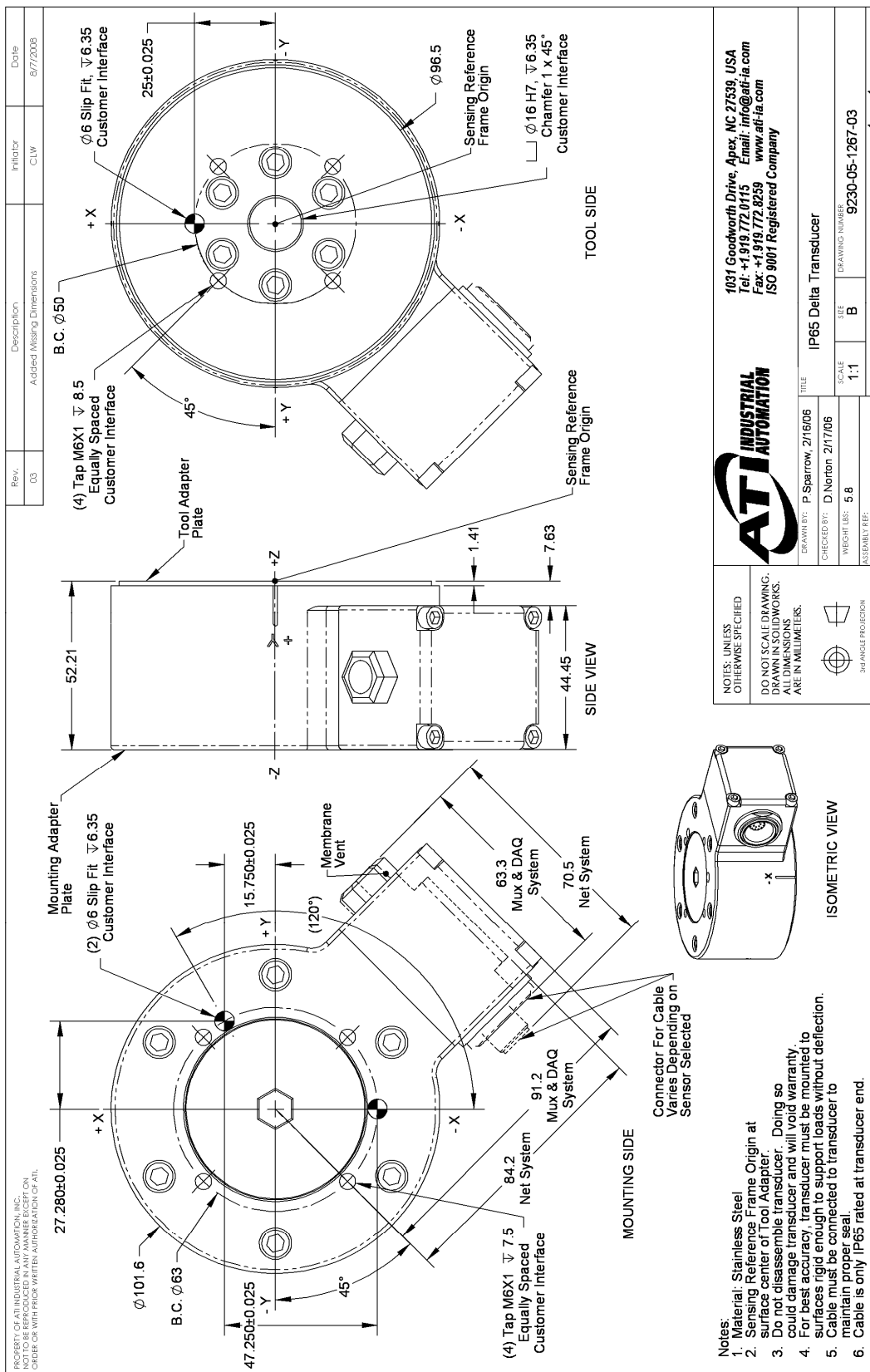

4.10.13 Delta IP68 Transducer

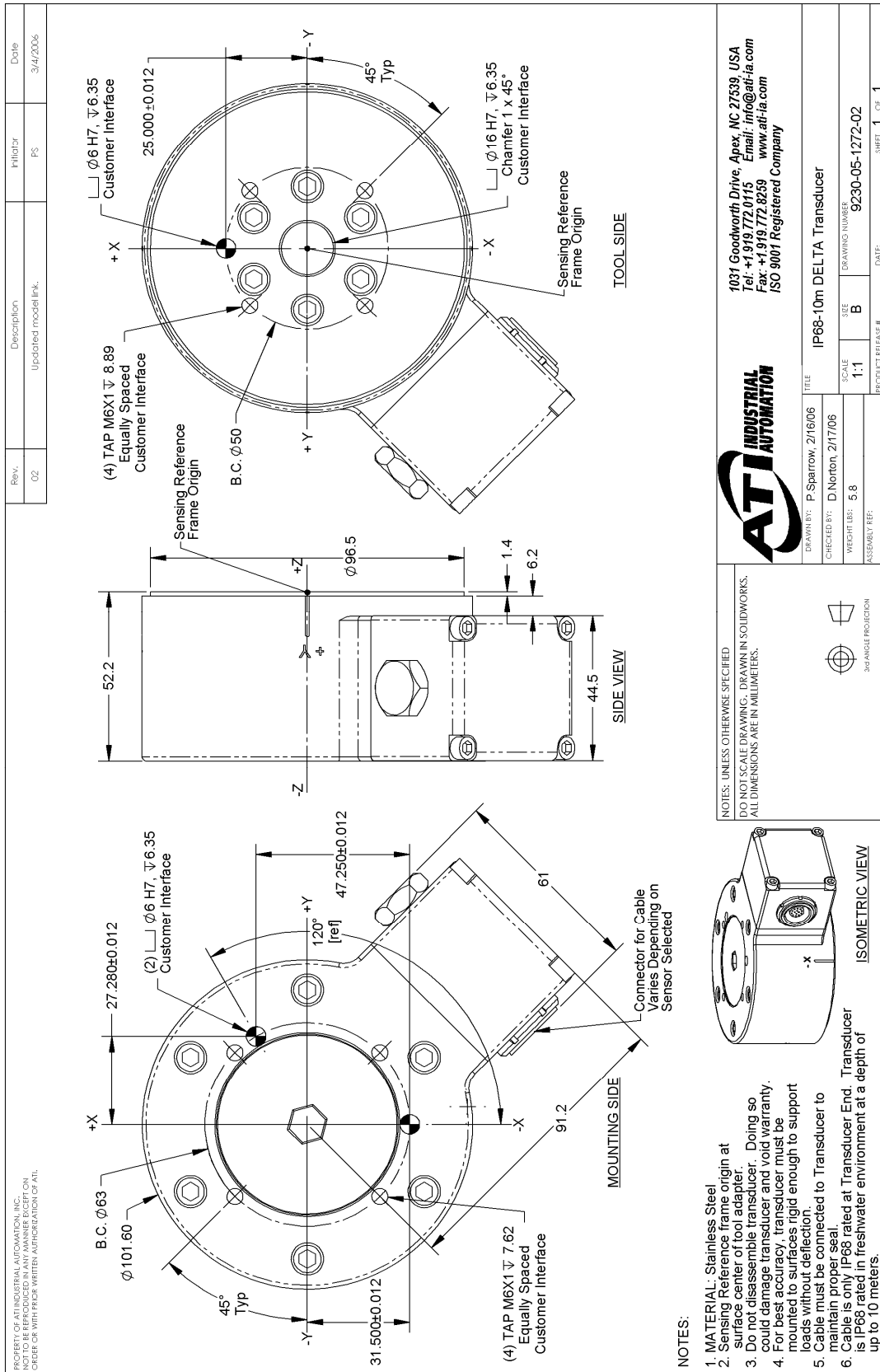

4.11 Theta (Includes IP60/IP65/IP68 Versions)

4.11.1 Calibration Specifications (excludes CTL calibrations)

US (English)

Calibration	Fx,Fy	Fz***	Tx,Ty	Tz	Fx,Fy	Fz***	Tx,Ty	Tz
US-200–1000	200 lbf	500 lbf	1000 lbf-in	1000 lbf-in	1/32 lbf	1/16 lbf	1/8 lbf-in	1/8 lbf-in
US-300–1800	300 lbf	875 lbf	1800 lbf-in	1800 lbf-in	5/68 lbf	5/34 lbf	5/16 lbf-in	5/16 lbf-in
US-600–3600	600 lbf	1500 lbf	3600 lbf-in	3600 lbf-in	1/8 lbf	1/4 lbf	1/2 lbf-in	1/2 lbf-in
	SENSING RANGES				RESOLUTION*			

SI (Metric)

Calibration	Fx,Fy	Fz***	Tx,Ty	Tz	Fx,Fy	Fz***	Tx,Ty	Tz
SI-1000–120	1000 N	2500 N	120 Nm	120 Nm	1/4 N	1/4 N	1/40 Nm	1/80 Nm
SI-1500–240	1500 N	3750 N	240 Nm	240 Nm	1/2 N	1/2 N	1/20 Nm	1/40 Nm
SI-2500–400	2500 N	6250 N	400 Nm	400 Nm	1/2 N	1 N	1/20 Nm	1/20 Nm
	SENSING RANGES				RESOLUTION*			

* DAQ resolutions are typical for a 16-bit data acquisition system.

These system resolutions quoted are the effective resolution after dropping four counts of noise. The effective resolution can be improved with filtering. NOTE: Applied loads must be within range in each of the six axes for the F/T sensor to measure correctly.

4.11.2 CTL Calibration Specifications

US (English)

Calibration	Fx,Fy	Fz†	Tx,Ty	Tz	Fx,Fy	Fz†	Tx,Ty	Tz
US-200–1000	200 lbf	500 lbf	1000 lbf-in	1000 lbf-in	1/16 lbf	1/8 lbf	1/4 lbf-in	1/4 lbf-in
US-300–1800	300 lbf	875 lbf	1800 lbf-in	1800 lbf-in	5/34 lbf	5/17 lbf	5/8 lbf-in	5/8 lbf-in
US-600–3600	600 lbf	1500 lbf	3600 lbf-in	3600 lbf-in	1/4 lbf	1/2 lbf	1 lbf-in	1 lbf-in

SI (Metric)

SI-1000–120	1000 N	2500 N	120 Nm	120 Nm	1/2 N	1/2 N	1/20 Nm	1/40 Nm
SI-1500–240	1500 N	3750 N	240 Nm	240 Nm	1 N	1 N	1/10 Nm	1/20 Nm
SI-2500–400	2500 N	6250 N	400 Nm	400 Nm	1 N	2 N	1/10 Nm	1/10 Nm
SENSING RANGES				RESOLUTION				

US (English)

Calibration	Fx,Fy	Fz†	Tx,Ty, Tz	Fx,Fy	Fz†	Tx,Ty, Tz
US-200–1000	±200 lbf	±500 lbf	±1000 lbf-in	20 lbf/V	50 lbf/V	100 lbf-in/V
US-300–1800	±300 lbf	±875 lbf	±1800 lbf-in	30 lbf/V	87.5 lbf/V	180 lbf-in/V
US-600–3600	±600 lbf	±1500 lbf	±3600 lbf-in	60 lbf/V	150 lbf/V	360 lbf-in/V

SI (Metric)

SI-1000–120	±1000 N	±2500 N	±120 Nm	100 N/V	250 N/V	12 Nm/V
SI-1500–240	±1500 N	±3750 N	±240 Nm	150 N/V	375 N/V	24 Nm/V
SI-2500–400	±2500 N	±6250 N	±400 Nm	250 N/V	625 N/V	40 Nm/V
Analog Output Range			Analog ±10V Sensitivity‡			

Counts Value

Calibration	Fx, Fy, Fz	Tx, Ty, Tz	Fx, Fy, Fz	Tx, Ty, Tz
US-200–1000 / SI-1000–120	128 / lbf	64 / lbf-in	32 / N	320 / Nm
US-300–1800 / SI-1500–240	54.4 / lbf	12.8 / lbf-in	16 / N	160 / Nm
US-600–3600 / SI-2500–400	32 / lbf	16 / lbf-in	16 / N	80 / Nm
Tool Transform Factor	See Tool Transform Factor table			
Counts Value – US (English)		Counts Value – SI (Metric)		

Tool Transform Factor

Calibration	US (English)	SI (Metric)
SI-1000–120	0.02 in/unit	1 mm/unit
SI-1500–240	0.0425 in/unit	1 mm/unit
SI-2500–400	0.02 in/unit	2 mm/unit

CTL resolutions are typical. System resolutions quoted are the effective resolution after dropping eight counts of noise. The effective resolution can be improved with filtering. NOTE: Applied loads must be within range in each of the six axes for the F/T sensor to measure correctly.

† For IP68 version see caution on physical properties page.

‡ ±5V Sensitivity values are double the listed ±10V Sensitivity values.

**4.11.3 Theta Physical Properties (Includes IP60/IP65/IP68 Versions)
US (English)**

Single-Axis Overload	
Fxy	±4100 lbf
Fz	±11000 lbf
Txy	±22000 lbf-in
Tz	±20000 lbf-in
Stiffness (Calculated)	
X-axis & Y-axis forces (Kx, Ky)	4.0x10 ⁵ lb/in
Z-axis force (Kz)	6.9x10 ⁵ lb/in
X-axis & Y-axis torque (Ktx, Kty)	3.0x10 ⁶ lbf-in/rad
Z-axis torque (Ktz)	4.7x10 ⁶ lbf-in/rad
Resonant Frequency (Measured)	
Fx, Fy, Tz	680 Hz
Fz, Tx, Ty	820 Hz
Physical Specifications	
Weight*	11 lb
Diameter*	6.1 in
Height*	2.4 in

SI (Metric)

Single-Axis Overload	
Fxy	±18000 N
Fz	±49000 N
Txy	±2500 Nm
Tz	±2300 Nm
Stiffness (Calculated)	
X-axis & Y-axis forces (Kx, Ky)	7.1x10 ⁷ N/m
Z-axis force (Kz)	1.2x10 ⁸ N/m
X-axis & Y-axis torque (Ktx, Kty)	3.4x10 ⁵ Nm/rad
Z-axis torque (Ktz)	5.3x10 ⁵ Nm/rad
Resonant Frequency (Measured)	
Fx, Fy, Tz	680 Hz
Fz, Tx, Ty	820 Hz
Physical Specifications	
Weight*	4.99 kg
Diameter*	150 mm
Height*	61 mm

* Specifications include standard interface plates.



CAUTION:

IP68 Theta Fz as a Function of Submersion Depth:

When submerged, IP68 transducers exhibit a decrease in Fz range related to the submersion depth. This loss is the result of pressure-induced preloading on the transducer. The preload can be masked by biasing the transducer at the depth prior to applying the load to be measured. The following estimates are for room temperature fresh water at seal level.

IP68 Theta	US	Metric
Fz preload at 10m depth	-429 lb	-1907 N
Fz preload at other depths	-13 lb/ft × depthInFeet	-191 N/m × depthInMeters

**4.11.4 Theta (US Calibration Complex Loading)
 (Includes IP60/IP65/IP68 Versions)**

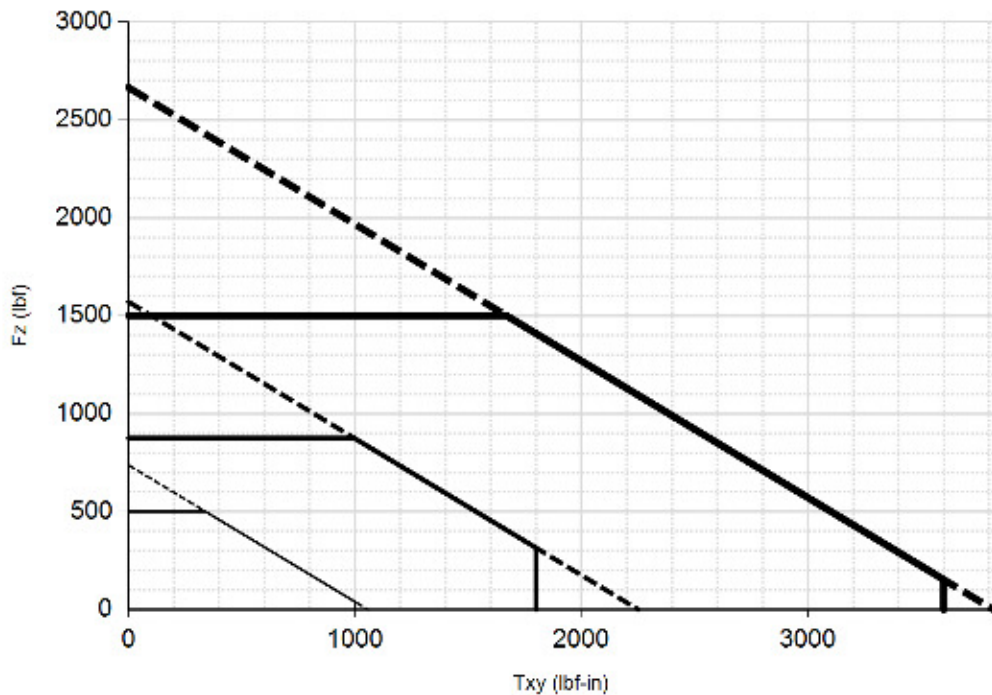
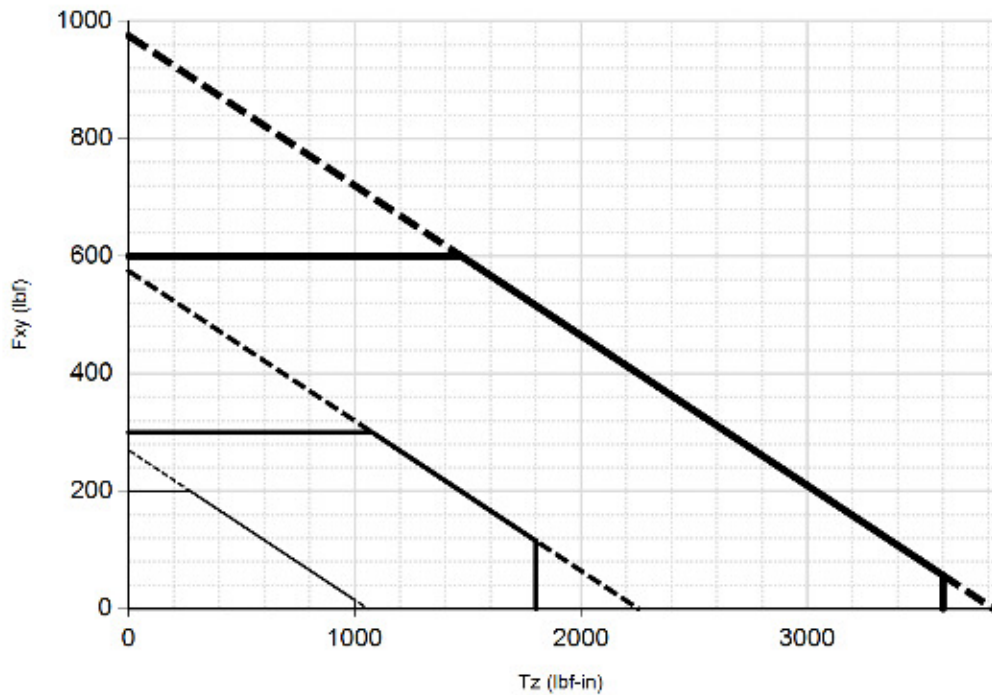

US-200-1000
 US-300-1800
 US-600-3600

*** For IP68 version see caution on physical properties page.

**4.11.5 Theta (SI Calibration Complex Loading)
 (Includes IP60/IP65/IP68 Versions)**

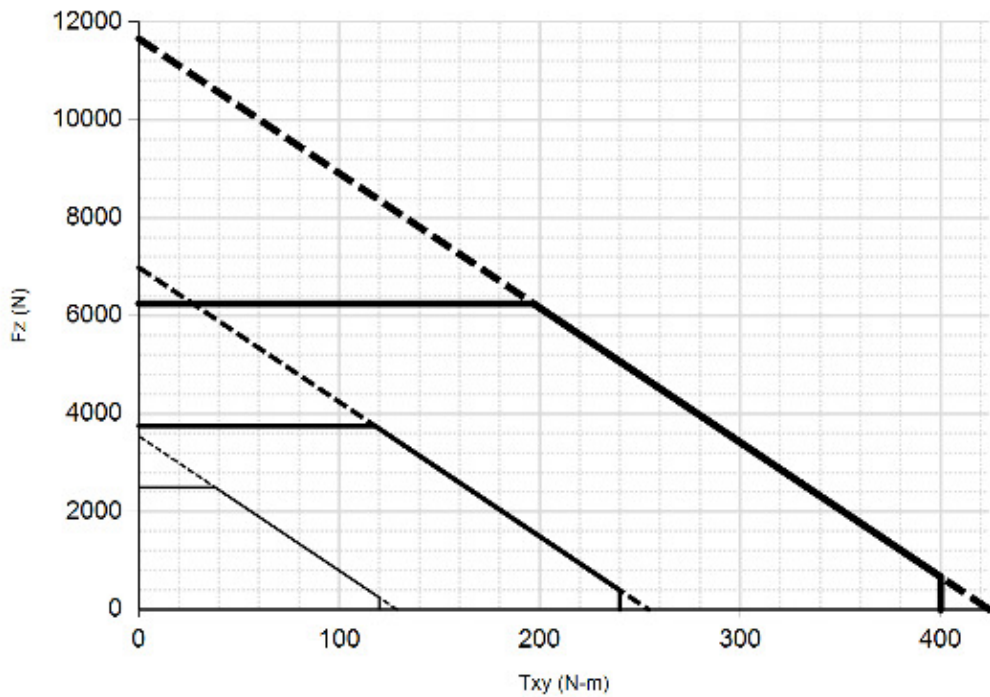
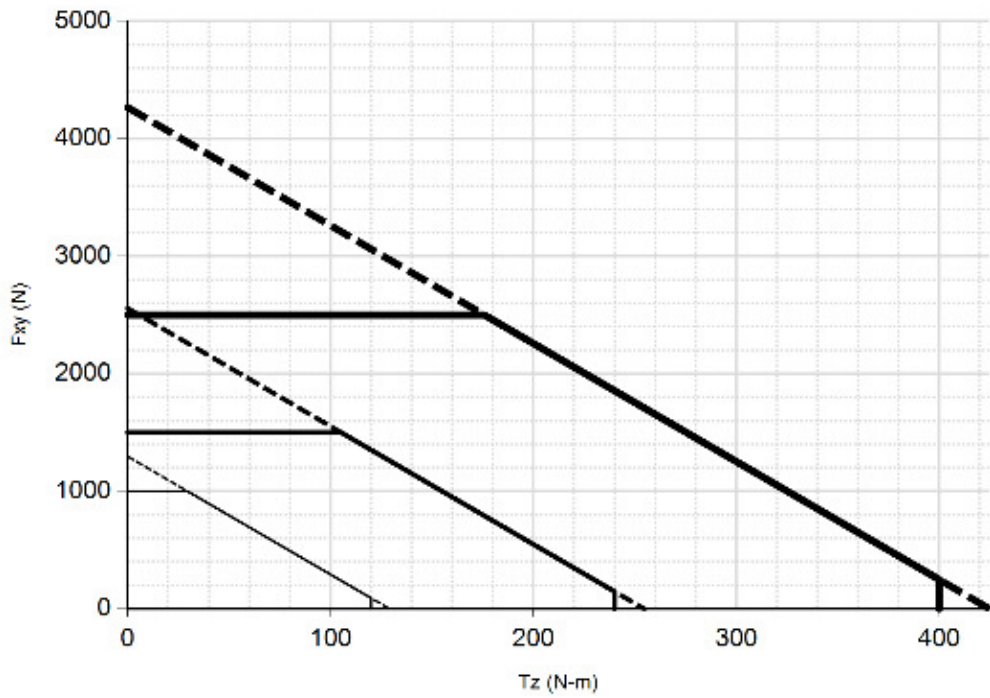

— SI-1000-120 — SI-1500-240 — SI-2500-400

*** For IP68 version see caution on physical properties page.

4.11.6 Theta DAQ/Net Transducer

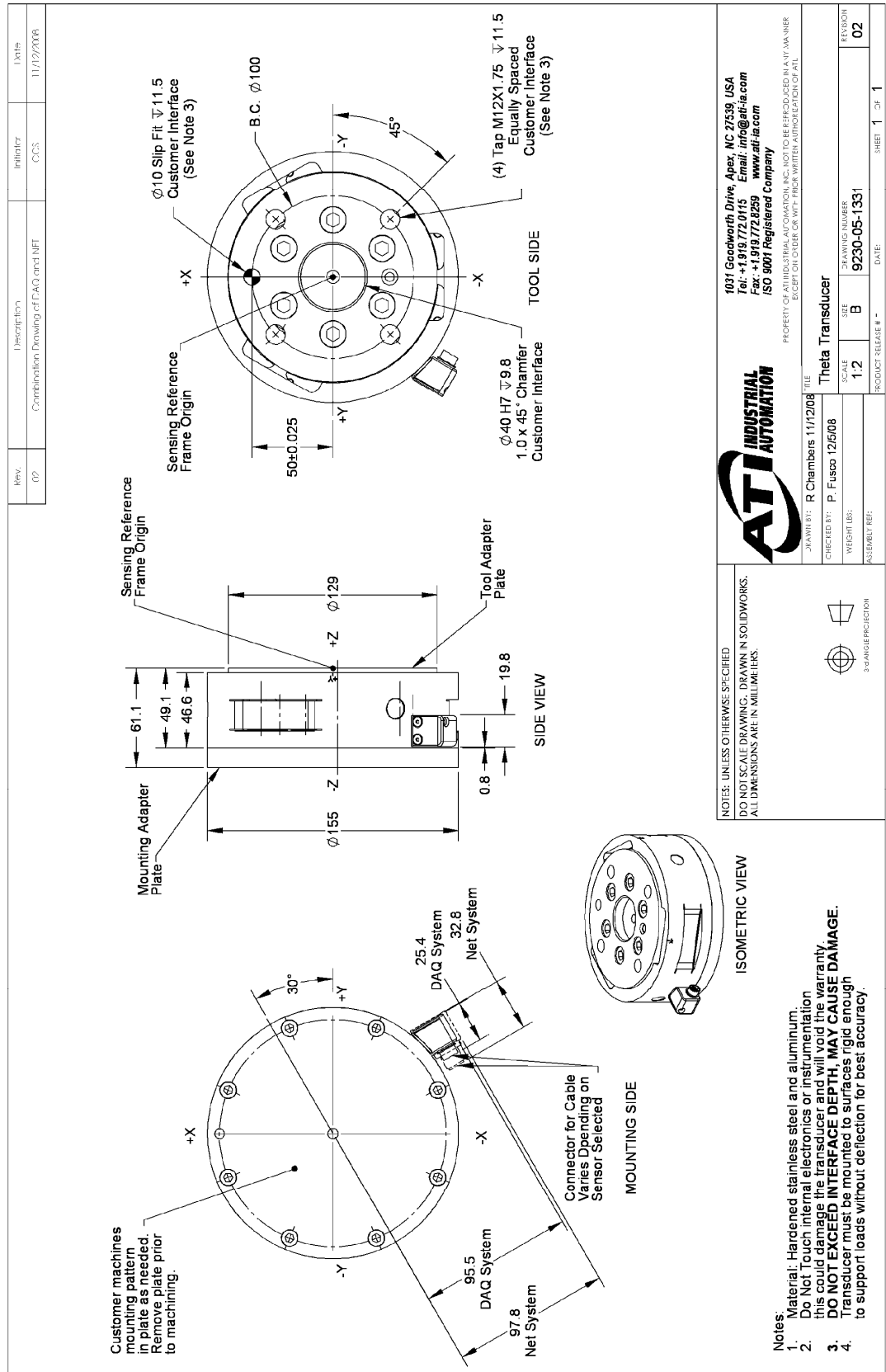

4.11.7 9105-T-Theta Transducer without Mounting Adapter Plate

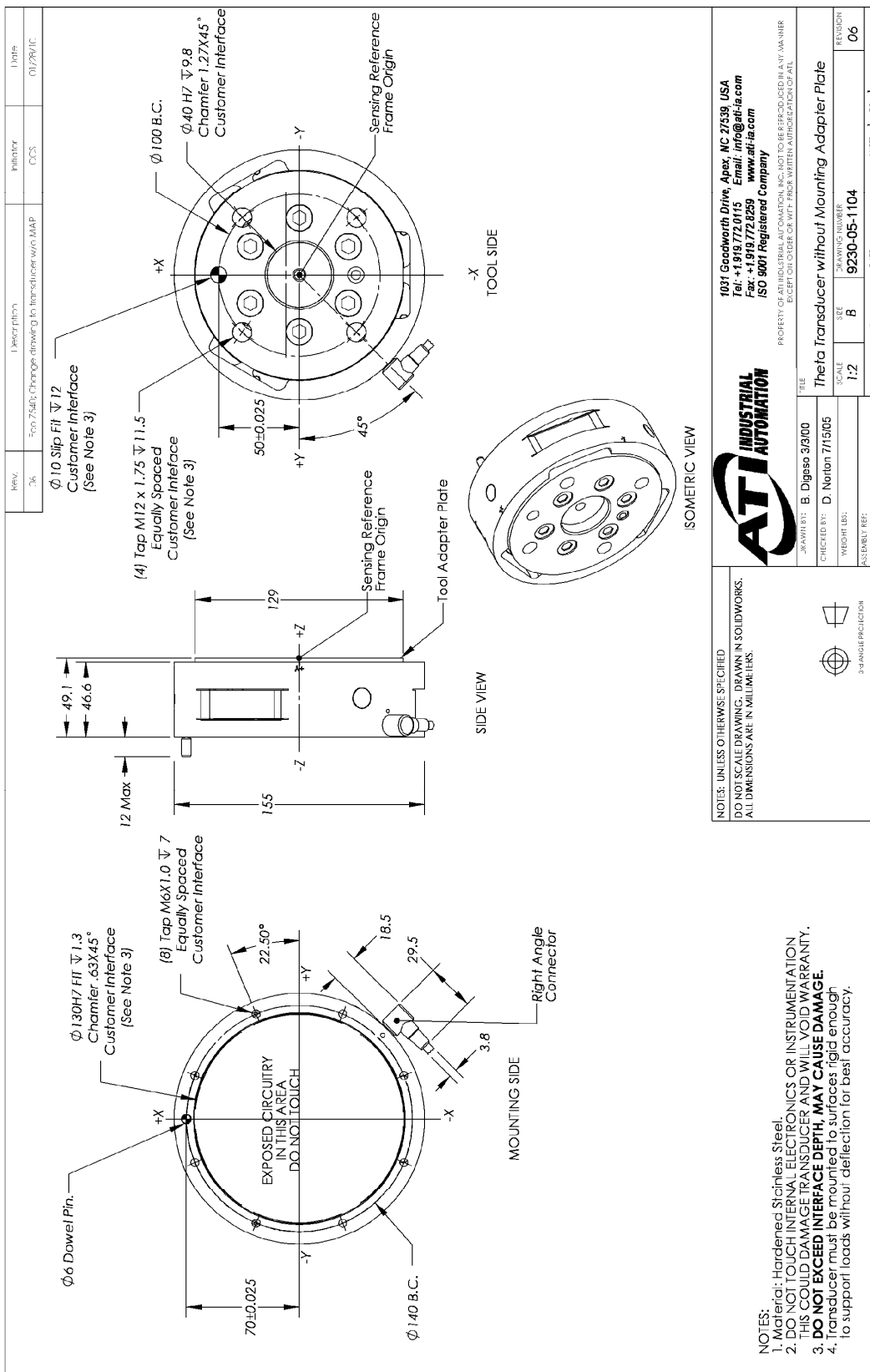

ATI INDUSTRIAL AUTOMATION

1031 Goodworth Drive, Apex, NC 27539 USA
 Tel: +1.919.772.0115 Email: info@ati-ia.com
 Fax: +1.919.772.8259 www.ati-ia.com
 ISO 9001 Registered Company

PROPERTY OF ATI INDUSTRIAL AUTOMATION. THIS DRAWING IS THE PROPERTY OF ATI INDUSTRIAL AUTOMATION. EXCEPT ON ORDER, CANNOT BE REPRODUCED OR TRANSMITTED IN ANY FORM OR BY ANY MEANS.

FILE: Theta Transducer without Mounting Adapter Plate
 DRAWN BY: B. Digoso 3/3/00
 CHECKED BY: D. Norton 7/15/05
 SCALE: 1:2
 WEIGHT LBS: B
 ASSEMBLY REF: B

PRODUCT RELEASE # - 9230-05-1104
 DATE: 06/06/10
 SHEET 1 OF 1

NOTES: UNLESS OTHERWISE SPECIFIED
 DO NOT SCALE DRAWING. DRAWN IN SOLIDWORKS.
 ALL DIMENSIONS ARE IN MILLIMETERS.

3/16 ANGLE SPECIFICATION

Note: Mux transducers are used in F/T Controller systems.

4.11.8 Theta Mounting Adapter Plate

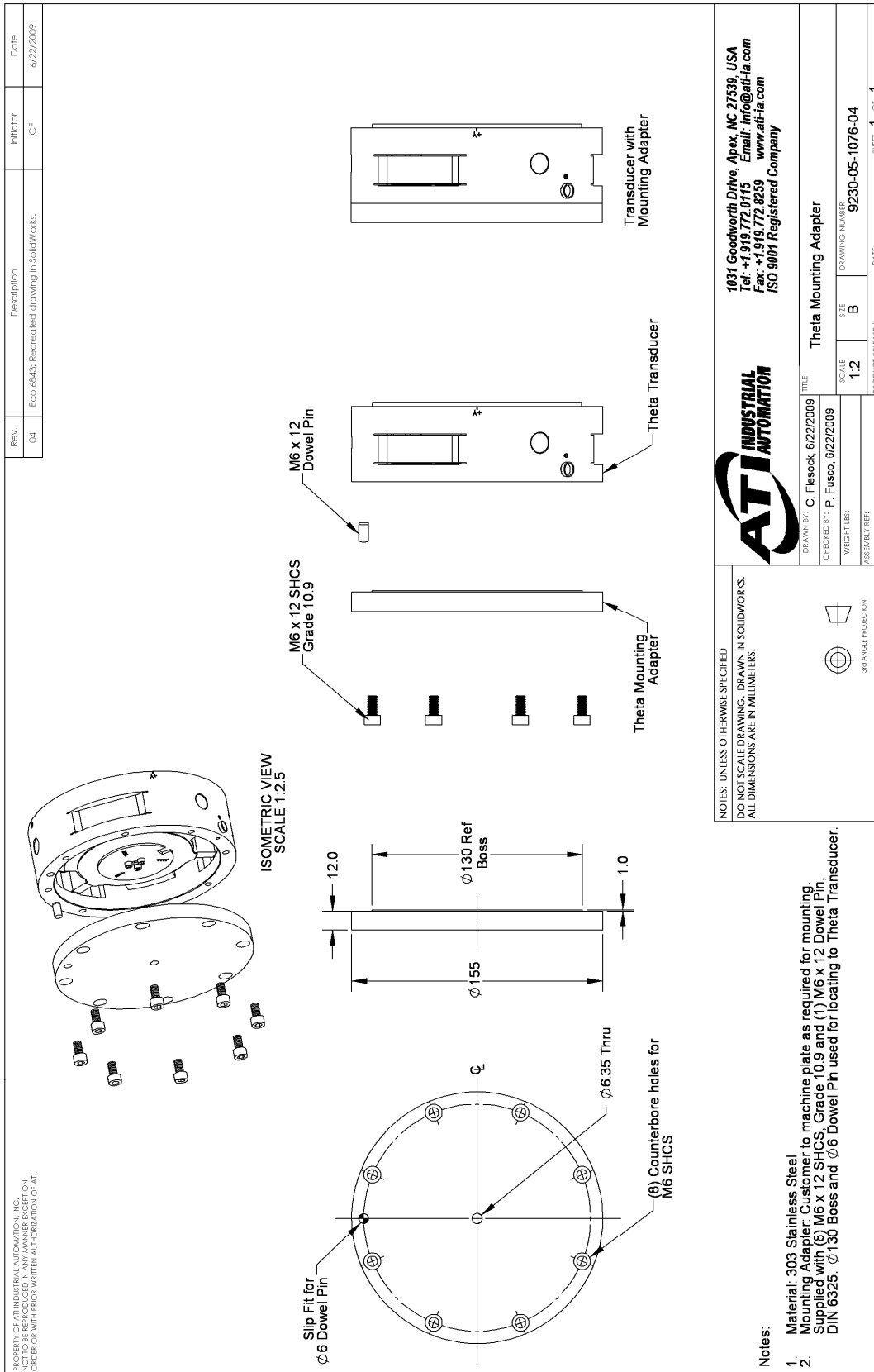

4.11.9 Theta IP60 Transducer

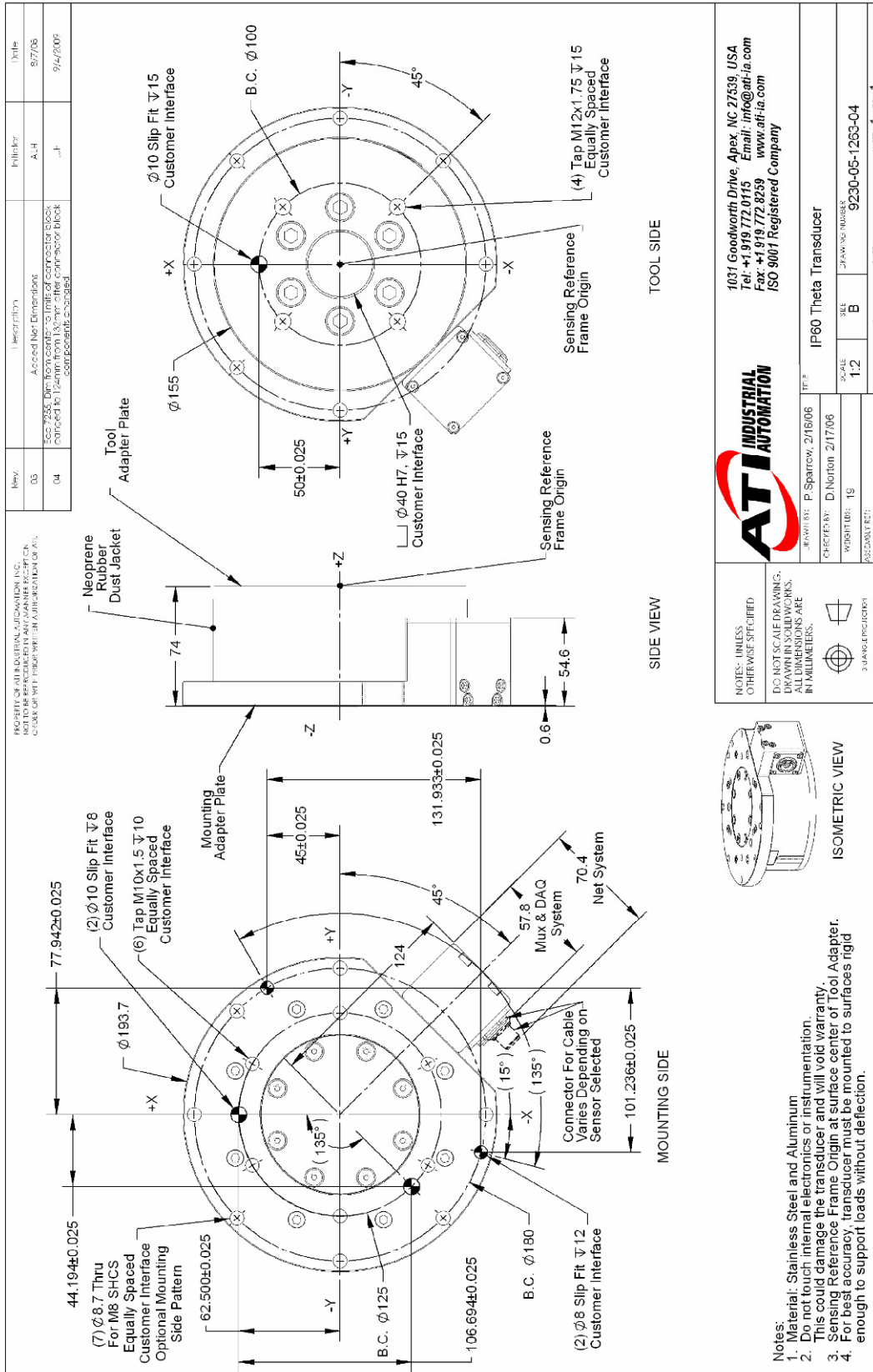

4.11.10 Theta IP65 Transducer

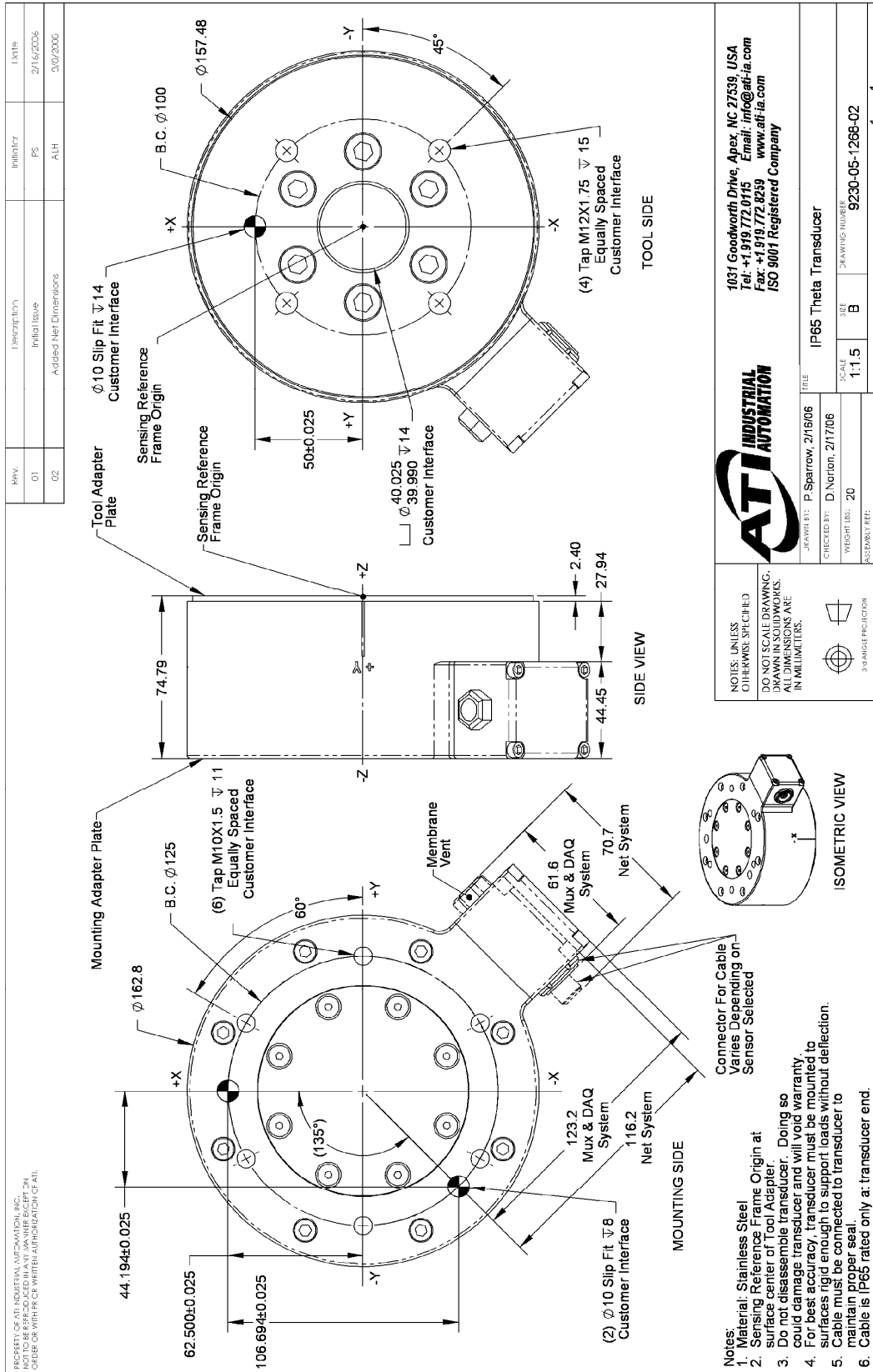

4.11.11 Theta IP68 Transducer

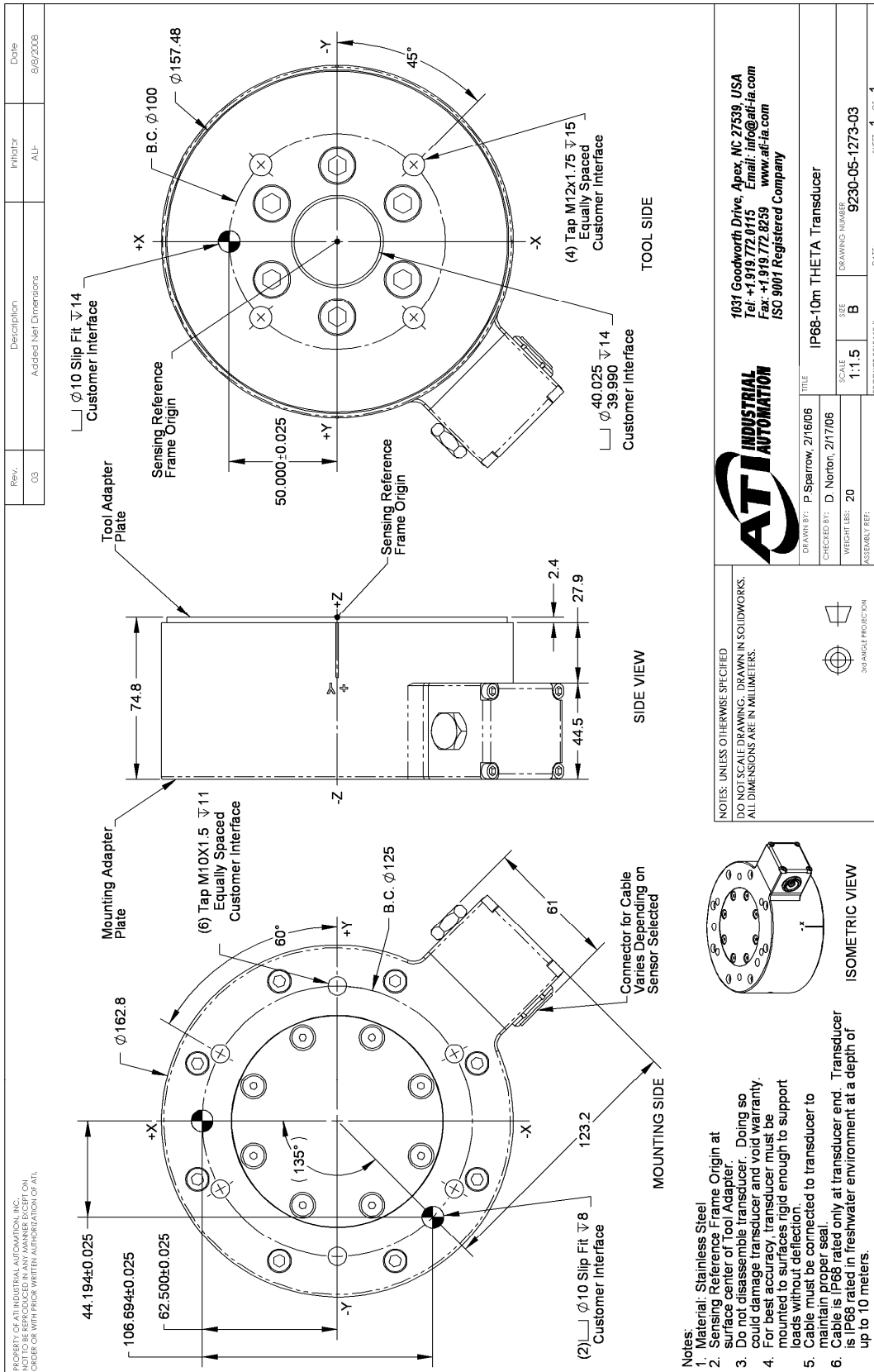

ATI INDUSTRIAL AUTOMATION

1031 Goodworth Drive, Apex, NC 27539, USA
 Tel: +1.919.772.0115 Email: info@ati-ia.com
 Fax: +1.919.772.8259 www.ati-ia.com
 ISO 9001 Registered Company

1031 Goodworth Drive, Apex, NC 27539, USA
 Tel: +1.919.772.0115 Email: info@ati-ia.com
 Fax: +1.919.772.8259 www.ati-ia.com
 ISO 9001 Registered Company

DRAWN BY: P. Sparrow, 2/16/06	TITLE: IP68-10m THETA Transducer
CHECKED BY: D. Norton, 2/17/06	DRAWING NUMBER: 9230-05-1273-03
WEIGHT LBS: 20	SCALE: 1:1.5
ASSEMBLY REF:	SIZE: B
PRODUCT RELEASE #	SHEET 1 OF 1

NOTES: UNLESS OTHERWISE SPECIFIED
 DO NOT SCALE DRAWING. DRAWN IN SOLIDWORKS.
 ALL DIMENSIONS ARE IN MILLIMETERS.

30° ANGLE PROJECTION

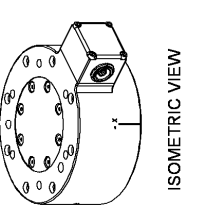

4.12 Omega160 (Includes IP60/IP65/IP68 Versions)

4.12.1 Calibration Specifications (excludes CTL calibrations)

US (English)

Calibration	Fx,Fy	Fz†	Tx,Ty	Tz	Fx,Fy	Fz†	Tx,Ty	Tz
US-200–1000	200 lbf	500 lbf	1000 lbf-in	1000 lbf-in	1/32 lbf	1/16 lbf	1/8 lbf-in	1/8 lbf-in
US-300–1800	300 lbf	875 lbf	1800 lbf-in	1800 lbf-in	5/68 lbf	5/34 lbf	5/16 lbf-in	5/16 lbf-in
US-600–3600	600 lbf	1500 lbf	3600 lbf-in	3600 lbf-in	1/8 lbf	1/4 lbf	1/2 lbf-in	1/4 lbf-in

SI (Metric)

SI-1000–120	1000 N	2500 N	120 Nm	120 Nm	1/4 N	1/4 N	1/40 Nm	1/80 Nm
SI-1500–240	1500 N	3750 N	240 Nm	240 Nm	1/4 N	1/2 N	1/20 Nm	1/40 Nm
SI-2500–400	2500 N	6250 N	400 Nm	400 Nm	1/2 N	3/4 N	1/20 Nm	1/20 Nm
	SENSING RANGES				RESOLUTION*			

* DAQ resolutions are typical for a 16-bit system.

These system resolutions quoted are the effective resolution after dropping four counts of noise. The effective resolution can be improved with filtering. NOTE: Applied loads must be within range in each of the six axes for the F/T sensor to measure correctly.

4.12.2 CTL Calibration Specifications

US (English)

Calibration	Fx,Fy	Fz†	Tx,Ty	Tz	Fx,Fy	Fz†	Tx,Ty	Tz
US-200–1000	200 lbf	500 lbf	1000 lbf-in	1000 lbf-in	1/16 lbf	1/8 lbf	1/4 lbf-in	1/4 lbf-in
US-300–1800	300 lbf	875 lbf	1800 lbf-in	1800 lbf-in	5/34 lbf	5/17 lbf	5/8 lbf-in	5/8 lbf-in
US-600–3600	600 lbf	1500 lbf	3600 lbf-in	3600 lbf-in	1/4 lbf	1/2 lbf	1 lbf-in	1/2 lbf-in

SI (Metric)

SI-1000-120	1000 N	2500 N	120 Nm	120 Nm	1/2 N	1/2 N	1/20 Nm	1/40 Nm
SI-1500-240	1500 N	3750 N	240 Nm	240 Nm	1/2 N	1 N	1/10 Nm	1/20 Nm
SI-2500-400	2500 N	6250 N	400 Nm	400 Nm	1 N	1 1/2 N	1/10 Nm	1/10 Nm
SENSING RANGES					RESOLUTION			

US (English)

Calibration	Fx,Fy	Fz†	Tx,Ty, Tz	Fx,Fy	Fz†	Tx,Ty, Tz
US-200–1000	±200 lbf	±500 lbf	±1000 lbf-in	20 lbf/V	50 lbf/V	100 lbf-in/V
US-300–1800	±300 lbf	±875 lbf	±1800 lbf-in	30 lbf/V	87.5 lbf/V	180 lbf-in/V
US-600–3600	±600 lbf	±1500 lbf	±3600 lbf-in	60 lbf/V	150 lbf/V	360 lbf-in/V

SI (Metric)

SI-1000-120	±1000 N	±2500 N	±120 Nm	100 N/V	250 N/V	12 Nm/V
SI-1500-240	±1500 N	±3750 N	±240 Nm	150 N/V	375 N/V	24 Nm/V
SI-2500-400	±2500 N	±6250 N	±400 Nm	250 N/V	625 N/V	40 Nm/V
Analog Output Range				Analog ±10V Sensitivity‡		

Counts Value

Calibration	Fx, Fy, Fz	Tx, Ty, Tz	Fx, Fy, Fz	Tx, Ty, Tz
US-200–1000 / SI-1000–120	128 / lbf	64 / lbf-in	32 / N	320 / Nm
US-300–1800 / SI-1500–240	54.4 / lbf	12.8 / lbf-in	16 / N	160 / Nm
US-600–3600 / SI-2500–400	32 / lbf	16 / lbf-in	16 / N	80 / Nm
Tool Transform Factor	See Tool Transform Factor table			
Counts Value – US (English)		Counts Value – SI (Metric)		

Tool Transform Factor

Calibration	US (English)	SI (Metric)
US-200–1000	0.02 in/unit	1 mm/unit
US-300–1800	0.0425 in/unit	1 mm/unit
US-600–3600	0.02 in/unit	2 mm/unit

CTL resolutions are typical. System resolutions quoted are the effective resolution after dropping eight counts of noise. The effective resolution can be improved with filtering. NOTE: Applied loads must be within range in each of the six axes for the F/T sensor to measure correctly.

† For IP68 version see caution on physical properties page.

‡ ±5V Sensitivity values are double the listed ±10V Sensitivity values.

**4.12.3 Omega160 Physical Properties (Includes IP60/IP65/IP68 Versions)
US (English)**

Single-Axis Overload	
Fxy	±3900 lbf
Fz	±11000 lbf
Txy	±15000 lbf-in
Tz	±17000 lbf-in
Stiffness (Calculated)	
X-axis & Y-axis forces (Kx, Ky)	4.0x10 ⁵ lb/in
Z-axis force (Kz)	6.8x10 ⁵ lb/in
X-axis & Y-axis torque (Ktx, Kty)	2.9x10 ⁶ lbf-in/rad
Z-axis torque (Ktz)	4.6x10 ⁶ lbf-in/rad
Resonant Frequency (Measured)	
Fx, Fy, Tz	1300 Hz
Fz, Tx, Ty	1000 Hz
Physical Specifications	
Weight*	6 lb
Diameter*	6.1 in
Height*	2.2 in

SI (Metric)

Single-Axis Overload	
Fxy	±18000 N
Fz	±48000 N
Txy	±1700 Nm
Tz	±1900 Nm
Stiffness (Calculated)	
X-axis & Y-axis forces (Kx, Ky)	7.0x10 ⁷ N/m
Z-axis force (Kz)	1.2x10 ⁸ N/m
X-axis & Y-axis torque (Ktx, Kty)	3.3x10 ⁵ Nm/rad
Z-axis torque (Ktz)	5.2x10 ⁵ Nm/rad
Resonant Frequency (Measured)	
Fx, Fy, Tz	1300 Hz
Fz, Tx, Ty	1000 Hz
Physical Specifications	
Weight*	2.72 kg
Diameter*	160 mm
Height*	56 mm

* Specifications include standard interface plates.



CAUTION:

IP68 Omega160 Fz as a Function of Submersion Depth:

When submerged, IP68 transducers exhibit a decrease in Fz range related to the submersion depth. This loss is the result of pressure-induced preloading on the transducer. The preload can be masked by biasing the transducer at the depth prior to applying the load to be measured. The following estimates are for room temperature fresh water at seal level.

IP68 Omega160	US	Metric
Fz preload at 10m depth	-429 lb	-1907 N
Fz preload at other depths	-13 lb/ft × depthInFeet	-191 N/m × depthInMeters

**4.12.4 Omega160 (US Calibration Complex Loading)
 (Includes IP60/IP65/IP68 Versions)**

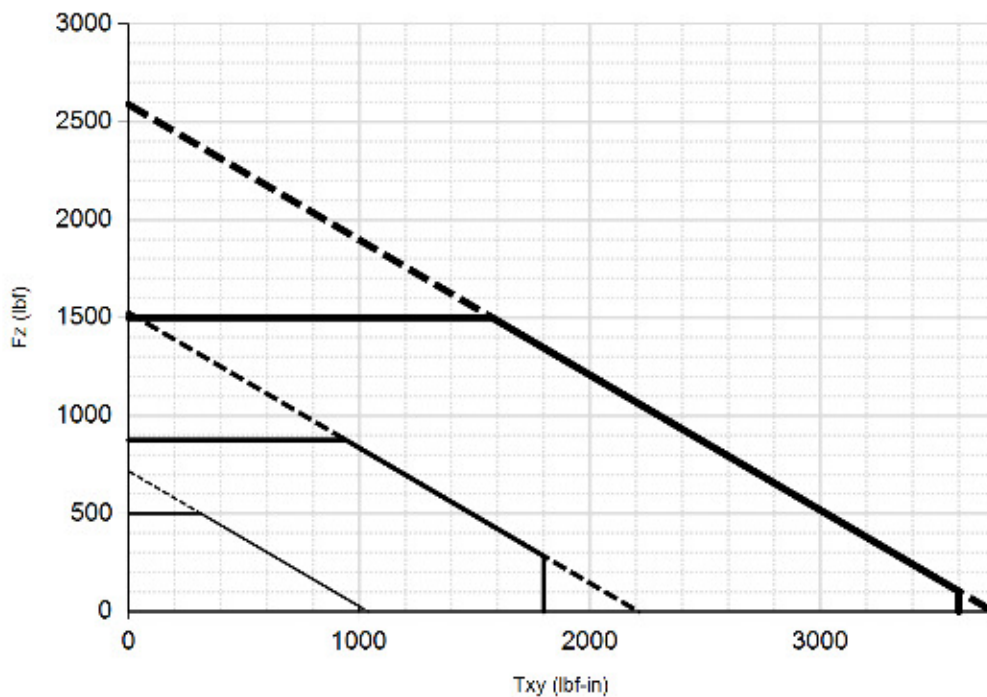
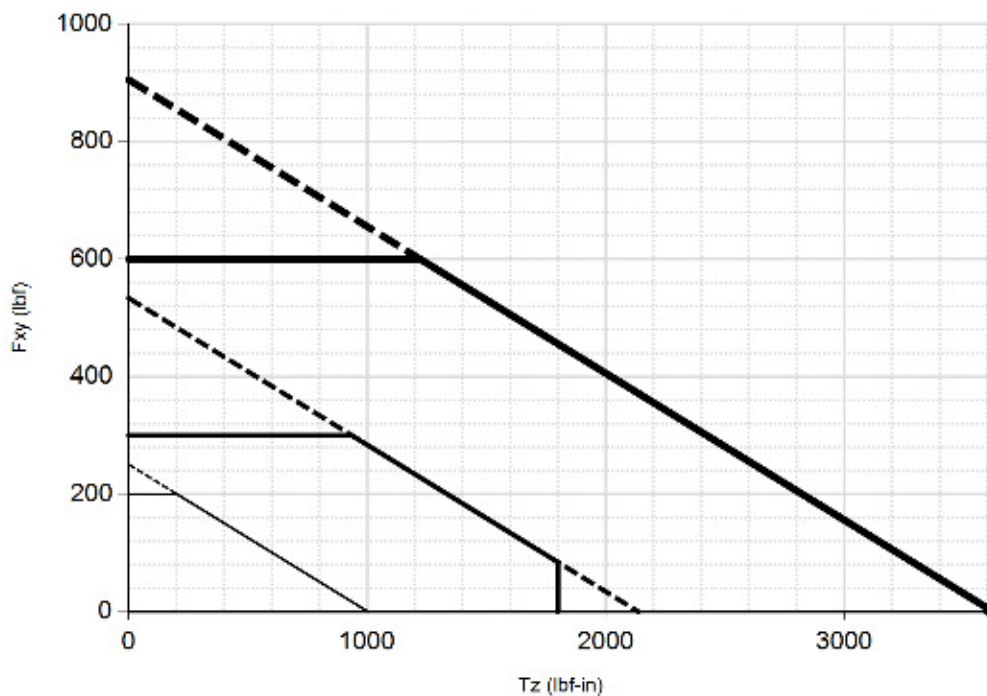

——— US-200-1000
——— US-300-1800
——— US-600-3600

*** For IP68 version see caution on physical properties page.

**4.12.5 Omega160 (SI Calibration Complex Loading)
 (Includes IP60/IP65/IP68 Versions)**

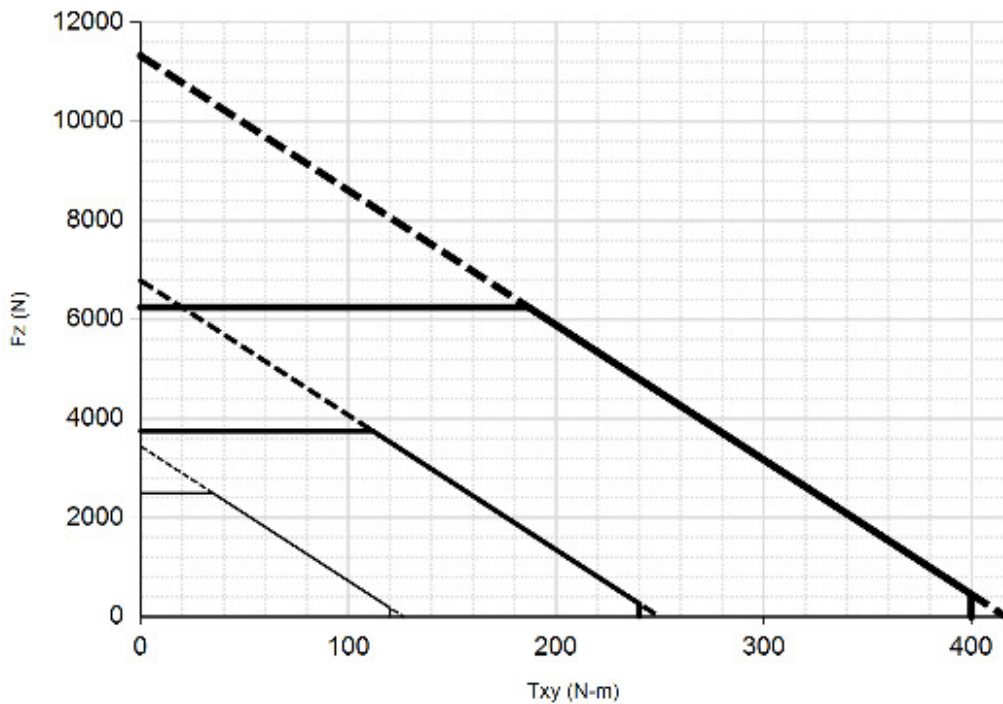
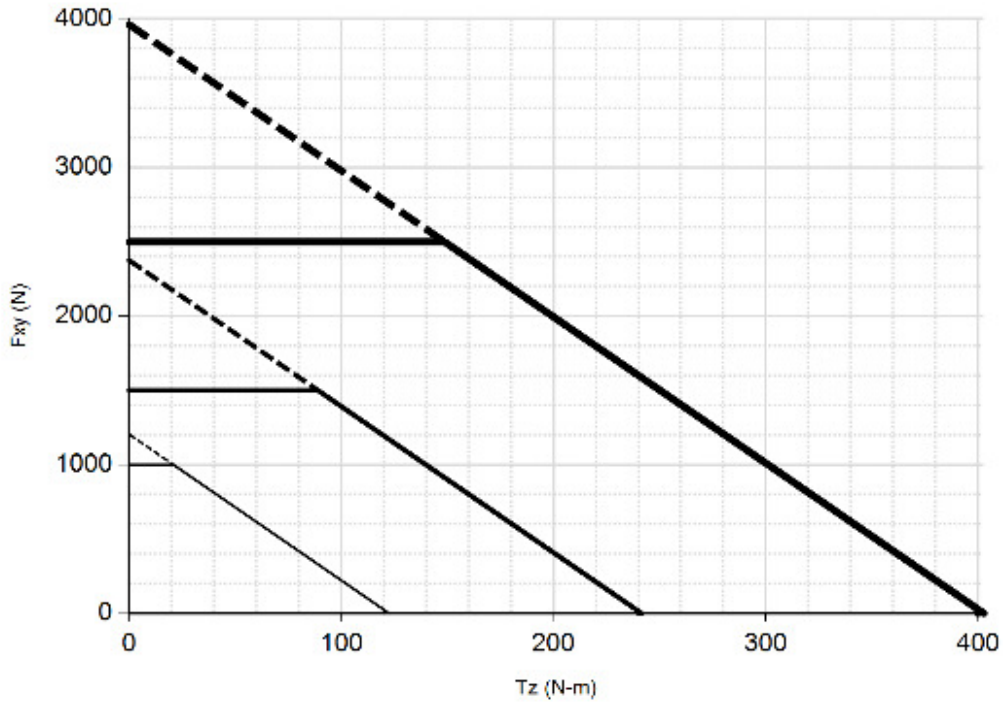

— SI-1000-120 — SI-1500-240 — SI-2500-400

*** For IP68 version see caution on physical properties page.

4.12.6 Omega160 Transducer with Mounting Adapter Plate

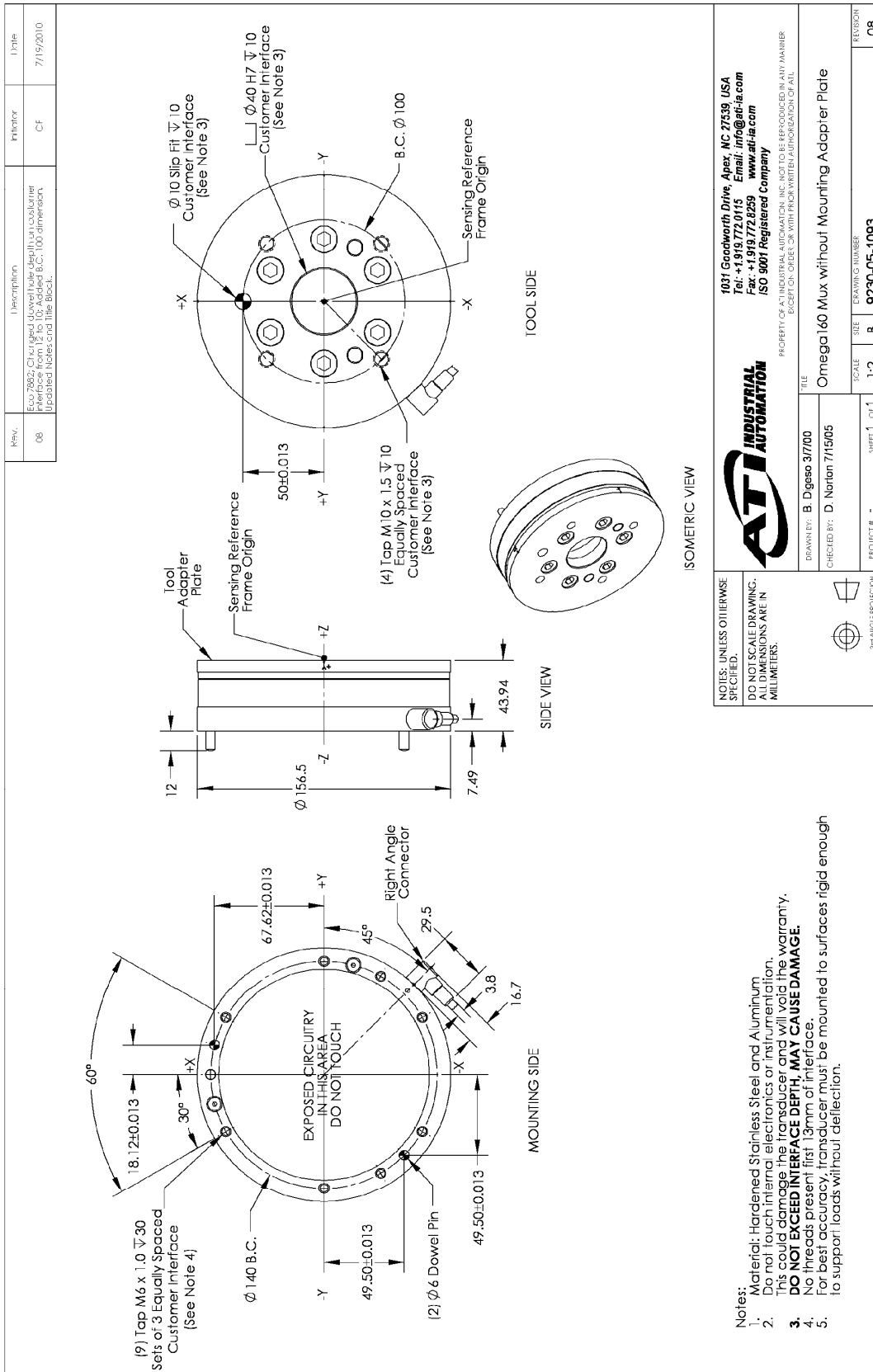

4.12.8 Omega160 IP60 Transducer

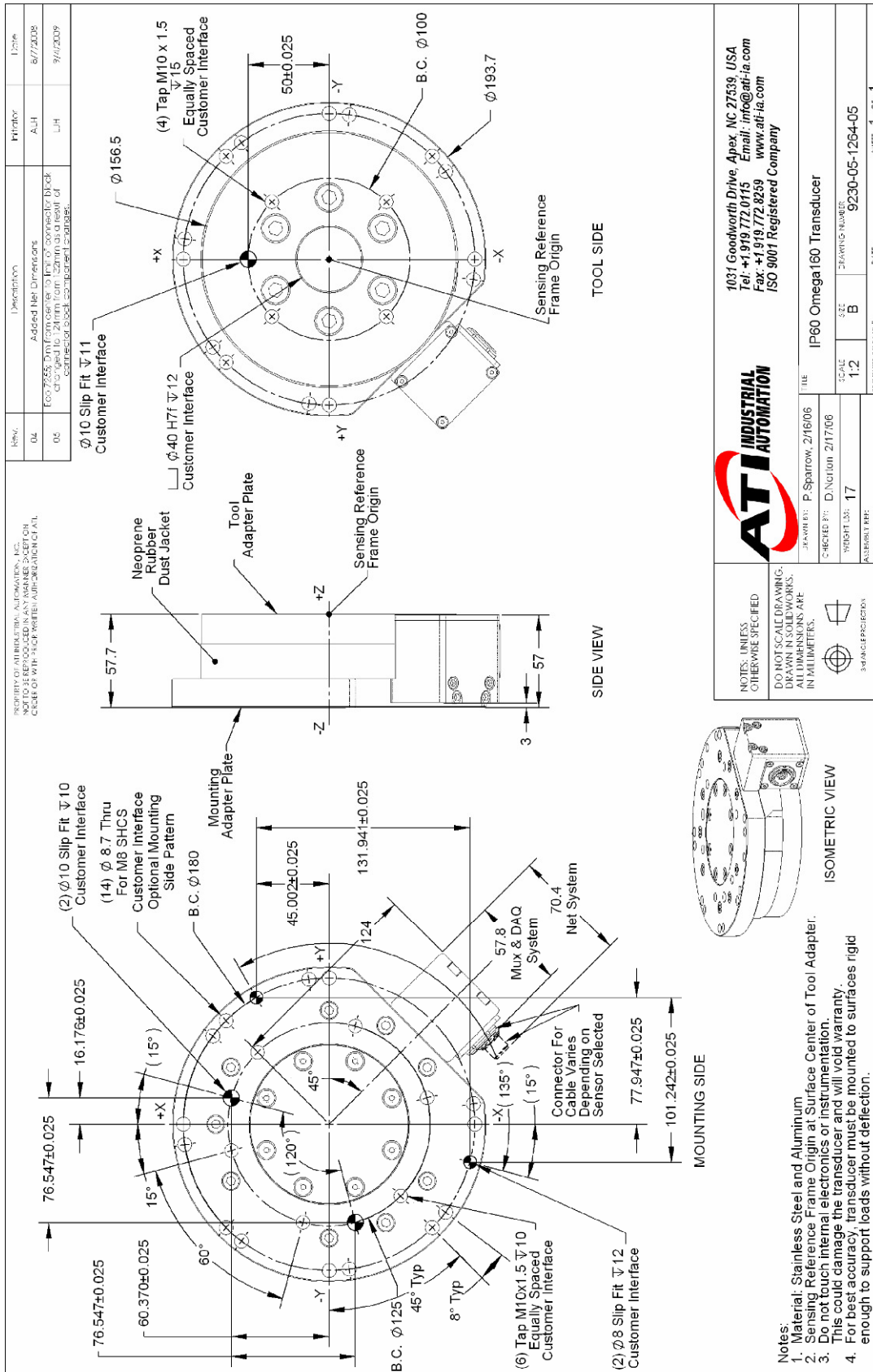

4.12.9 Omega160 IP65 Transducer

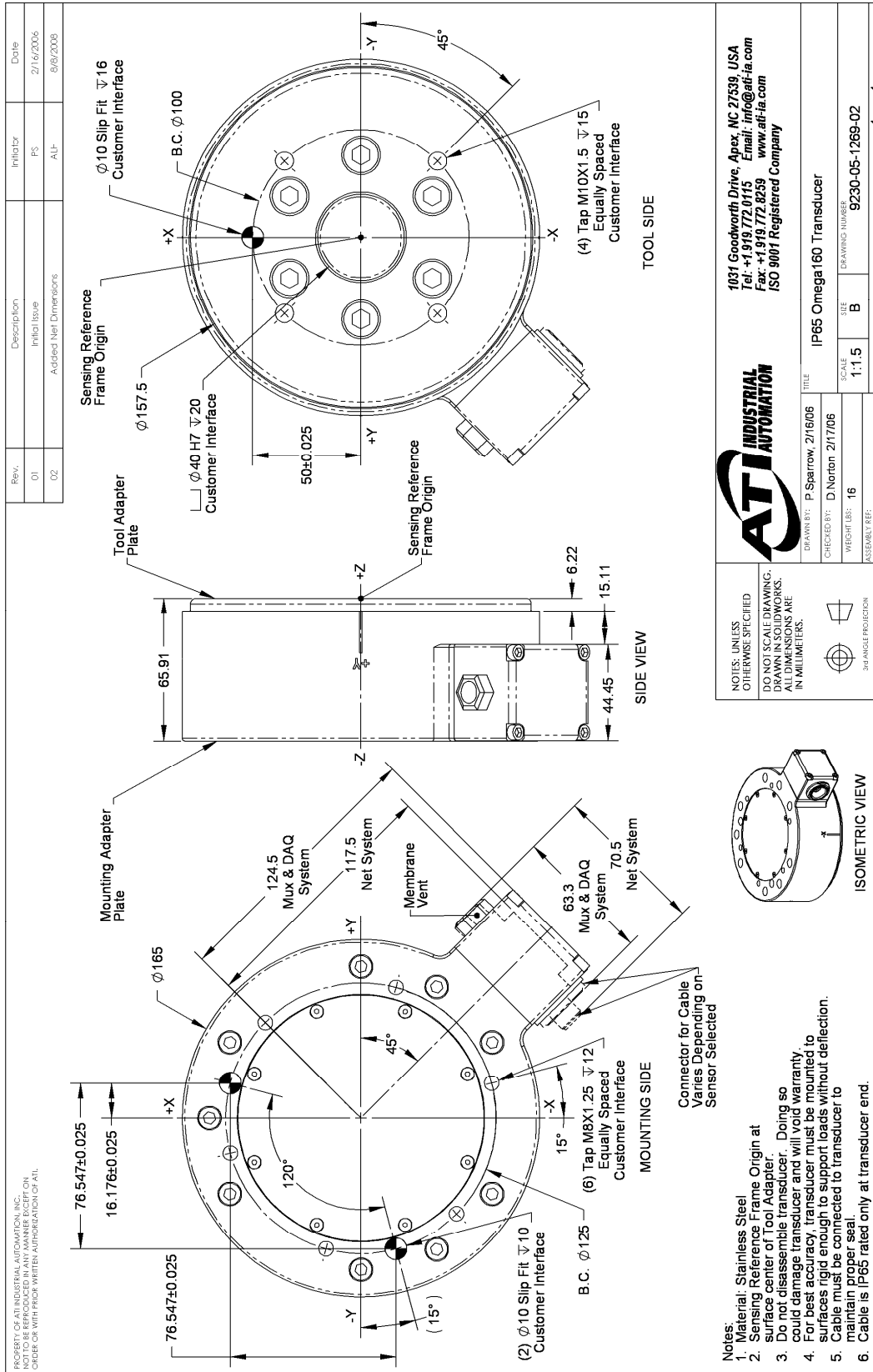

4.12.10 Omega160 IP68 Transducer

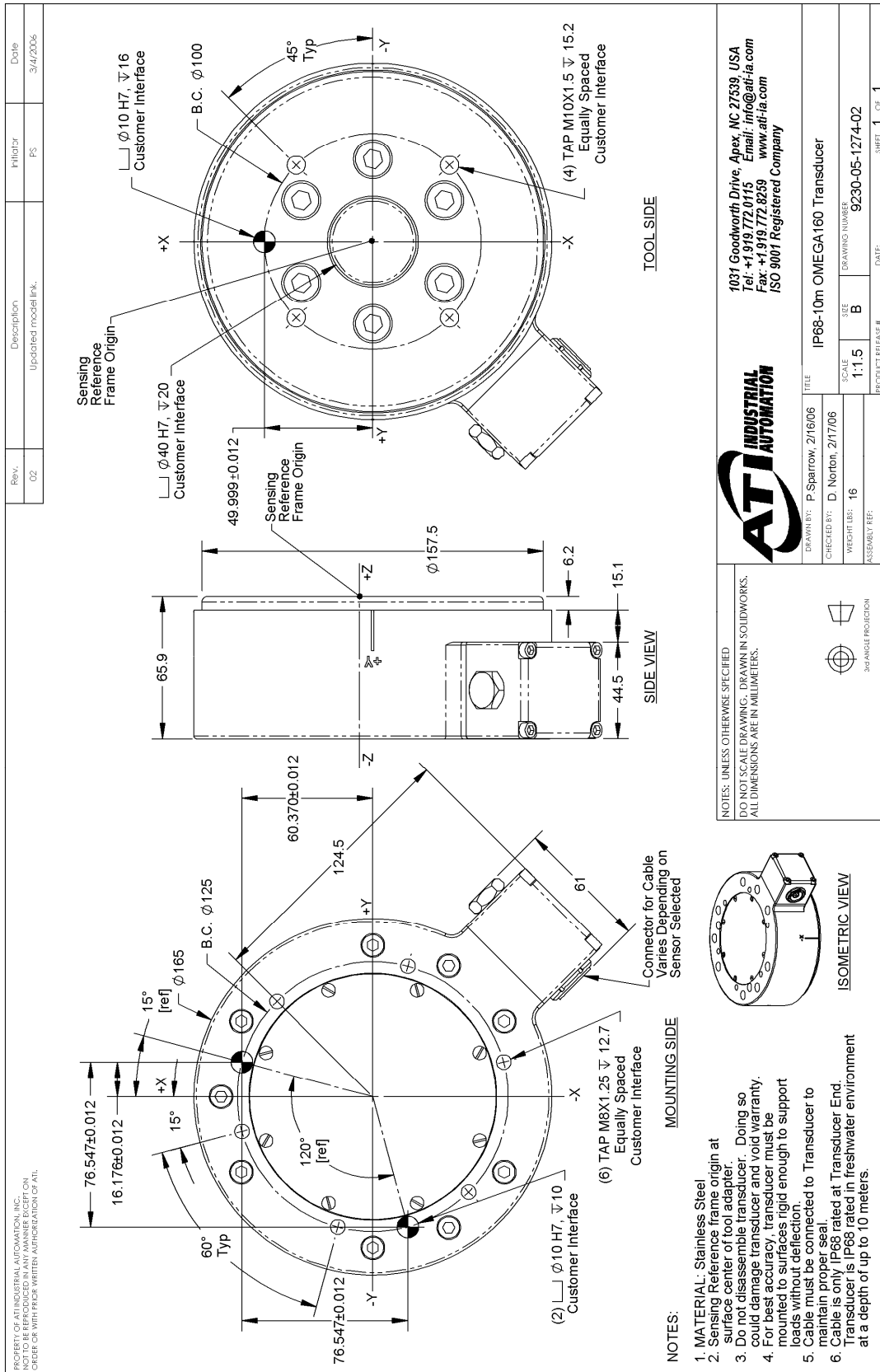

ATI INDUSTRIAL AUTOMATION

1031 Goodworth Drive, Apex, NC 27539, USA
 Tel: +1.919.772.0115 Email: info@ati-ia.com
 Fax: +1.919.772.8259 www.ati-ia.com
 ISO 9001 Registered Company

DRAWN BY: P. Sparrow, 2/16/06		TITLE: IP68-10m OMEGA160 Transducer	
CHECKED BY: D. Norton, 2/17/06		DRAWING NUMBER: 9230-05-1274-02	
SCALE: 1:1.5	SIZE: B	PRODUCT RELEASE #	SHEET 1 OF 1
WEIGHT LBS: 16		DATE:	
ASSEMBLY REF:			

NOTES: UNLESS OTHERWISE SPECIFIED
 DO NOT SCALE DRAWING. DRAWN IN SOLIDWORKS.
 ALL DIMENSIONS ARE IN MILLIMETERS.

3/4 ANGLE PROJECTION

4.13 Omega190 (Includes IP60/IP65/IP68 Versions)

4.13.1 Calibration Specifications (excludes CTL calibrations)

US (English)

Calibration	Fx,Fy	Fz†	Tx,Ty	Tz	Fx,Fy	Fz†	Tx,Ty	Tz
US-400-3000	400 lbf	1000 lbf	3000 lbf-in	3000 lbf-in	5/64 lbf	5/32 lbf	15/32 lbf-in	5/16 lbf-in
US-800-6000	800 lbf	2000 lbf	6000 lbf-in	6000 lbf-in	5/32 lbf	5/16 lbf	15/16 lbf-in	5/8 lbf-in
US-1600-12000	1600 lbf	4000 lbf	12000 lbf-in	12000 lbf-in	5/16 lbf	5/8 lbf	1 7/8 lbf-in	1 1/4 lbf-in

SI (Metric)

SI-1800-350	1800 N	4500 N	350 Nm	350 Nm	3/8 N	3/4 N	5/96 Nm	5/144 Nm
SI-3600-700	3600 N	9000 N	700 Nm	700 Nm	3/4 N	1 1/2 N	5/48 Nm	5/72 Nm
SI-7200-1400	7200 N	18000 N	1400 Nm	1400 Nm	1 1/2 N	3 N	5/24 Nm	5/36 Nm
	Sensing Ranges				Resolution*			

* DAQ resolutions are typical for a 16-bit data acquisition system.

These system resolutions quoted are the effective resolution after dropping four counts of noise. The effective resolution can be improved with filtering. NOTE: Applied loads must be within range in each of the six axes for the F/T sensor to measure correctly.

4.13.2 CTL Calibration Specifications

US (English)

Calibration	F _x ,F _y	F _z †	T _x ,T _y	T _z	F _x ,F _y	F _z †	T _x ,T _y	T _z
US-400-3000	400 lbf	1000 lbf	3000 lbf-in	3000 lbf-in	5/32 lbf	5/16 lbf	15/16 lbf-in	5/8 lbf-in
US-800-6000	800 lbf	2000 lbf	6000 lbf-in	6000 lbf-in	5/16 lbf	5/8 lbf	1 7/8 lbf-in	1 1/4 lbf-in
US-1600-12000	1600 lbf	4000 lbf	12000 lbf-in	12000 lbf-in	5/8 lbf	1 1/4 lbf	3 3/4 lbf-in	2 1/2 lbf-in
SENSING RANGES					RESOLUTION			

SI (Metric)

Calibration	F _x ,F _y	F _z †	T _x ,T _y	T _z	F _x ,F _y	F _z †	T _x ,T _y	T _z
SI-1800-350	1800 N	4500 N	350 Nm	350 Nm	3/4 N	1 1/2 N	5/48 Nm	5/72 Nm
SI-3600-700	3600 N	9000 N	700 Nm	700 Nm	1 1/2 N	3 N	5/24 Nm	5/36 Nm
SI-7200-1400	7200 N	18000 N	1400 Nm	1400 Nm	3 N	6 N	5/12 Nm	5/18 Nm
SENSING RANGES					RESOLUTION			

US (English)

Calibration	F _x ,F _y	F _z †	T _x ,T _y , T _z	F _x ,F _y	F _z †	T _x ,T _y , T _z
US-105–185	±400 lbf	±1000 lbf	±3000 lbf-in	40 lbf/V	100 lbf/V	300 lbf-in/V
US-210–370	±800 lbf	±2000 lbf	±6000 lbf-in	80 lbf/V	200 lbf/V	600 lbf-in/V
US-420–740	±1600 lbf	±4000 lbf	±12000 lbf-in	160 lbf/V	400 lbf/V	1200 lbf-in/V
Analog Output Range				Analog ±10V Sensitivity‡		

SI (Metric)

Calibration	F _x ,F _y	F _z †	T _x ,T _y , T _z	F _x ,F _y	F _z †	T _x ,T _y , T _z
SI-475–20	±1800 N	±4500 N	±350 Nm	180 N/V	450 N/V	35 Nm/V
SI-950–40	±3600 N	±9000 N	±700 Nm	360 N/V	900 N/V	70 Nm/V
SI-1900–80	±7200 N	±18000 N	±1400 Nm	720 N/V	1800 N/V	140 Nm/V
Analog Output Range				Analog ±10V Sensitivity‡		

Counts Value

Calibration	F _x , F _y , F _z	T _x , T _y , T _z	F _x , F _y , F _z	T _x , T _y , T _z
US-105–185 / SI-475–20	153.6 / lbf	307.2 / lbf-in	32 / N	230.4 / Nm
US-210–370 / SI-950–40	76.8 / lbf	153.6 / lbf-in	16 / N	115.2 / Nm
US-420–740 / SI-1900–80	38.4 / lbf	76.8 / lbf-in	8 / N	57.6 / Nm
Tool Transform Factor	0.005 in/unit		1.3889 mm/unit	
Counts Value – US (English)			Counts Value – SI (Metric)	

CTL resolutions are typical. System resolutions quoted are the effective resolution after dropping eight counts of noise. The effective resolution can be improved with filtering. NOTE: Applied loads must be within range in each of the six axes for the F/T sensor to measure correctly.

† For IP68 version see caution on physical properties page.

‡ ±5V Sensitivity values are double the listed ±10V Sensitivity values.

**4.13.3 Omega190 Physical Properties (Includes IP60/IP65/IP68 Versions)
US (English)**

Single-Axis Overload	
Fxy	±8000 lbf
Fz	±25000 lbf
Txy	±60000 lbf-in
Tz	±60000 lbf-in
Stiffness (Calculated)	
X-axis & Y-axis forces (Kx, Ky)	1.4x10 ⁶ lb/in
Z-axis force (Kz)	2.1x10 ⁶ lb/in
X-axis & Y-axis torque (Ktx, Kty)	1.4x10 ⁷ lbf-in/rad
Z-axis torque (Ktz)	2.8x10 ⁷ lbf-in/rad
Resonant Frequency (Measured)	
Fx, Fy, Tz	N/A
Fz, Tx, Ty	N/A
Physical Specifications	
Weight*	14 lb
Diameter*	7.5 in
Height*	2.2 in

SI (Metric)

Single-Axis Overload	
Fxy	±36000 N
Fz	±110000 N
Txy	±6800 Nm
Tz	±6800 Nm
Stiffness (Calculated)	
X-axis & Y-axis forces (Kx, Ky)	2.4x10 ⁸ N/m
Z-axis force (Kz)	3.6x10 ⁸ N/m
X-axis & Y-axis torque (Ktx, Kty)	1.5x10 ⁶ Nm/rad
Z-axis torque (Ktz)	3.2x10 ⁶ Nm/rad
Resonant Frequency (Measured)	
Fx, Fy, Tz	N/A
Fz, Tx, Ty	N/A
Physical Specifications	
Weight*	6.35 kg
Diameter*	190 mm
Height*	56 mm

* Specifications include standard interface plates.



CAUTION:

IP68 Omega190 Fz as a Function of Submersion Depth:

When submerged, IP68 transducers exhibit a decrease in Fz range related to the submersion depth. This loss is the result of pressure-induced preloading on the transducer. The preload can be masked by biasing the transducer at the depth prior to applying the load to be measured. The following estimates are for room temperature fresh water at seal level.

IP68 Omega190	US	Metric
Fz preload at 10m depth	-661 lb	-2941 N
Fz preload at other depths	$-20 \text{ lb/ft} \times \text{depthInFeet}$	$-294 \text{ N/m} \times \text{depthInMeters}$

**4.13.4 Omega190 (US Calibration Complex Loading)
 (Includes IP60/IP65/IP68 Versions)**

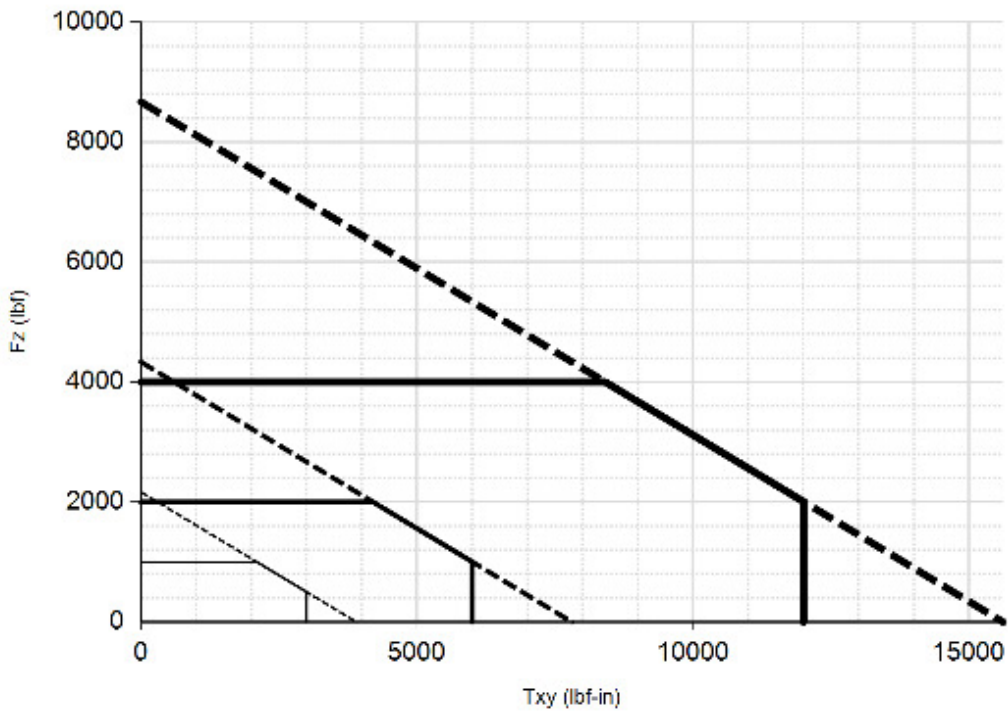
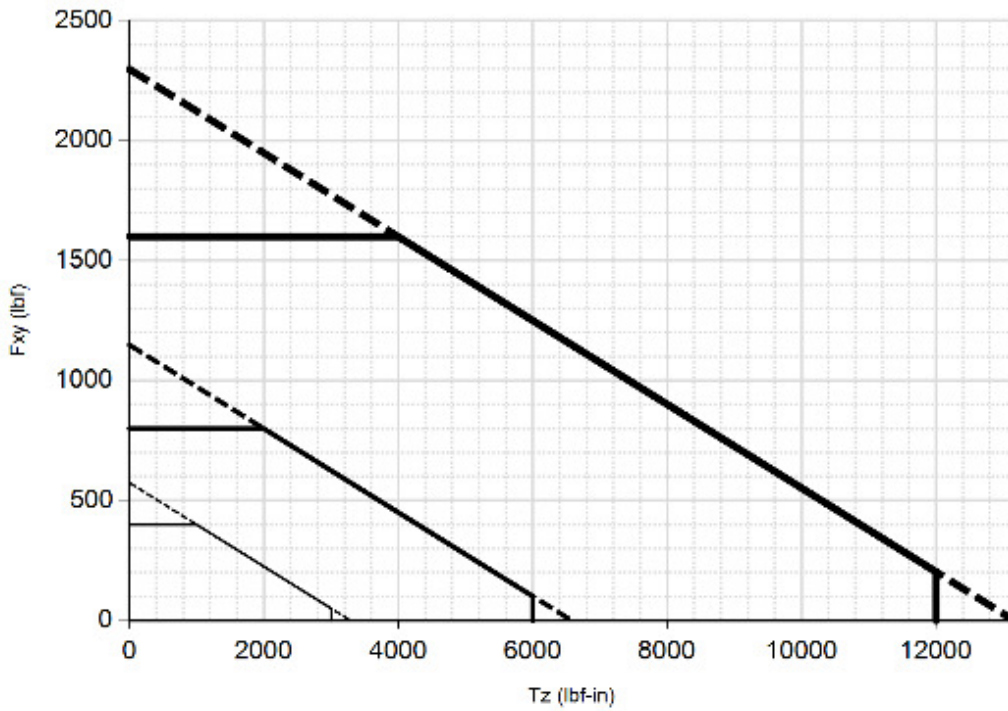

US-400-3000
 US-800-6000
 US-1600-12000

*** For IP68 version see caution on physical properties page.

**4.13.5 Omega190 (SI Calibration Complex Loading)
 (Includes IP60/IP65/IP68 Versions)**

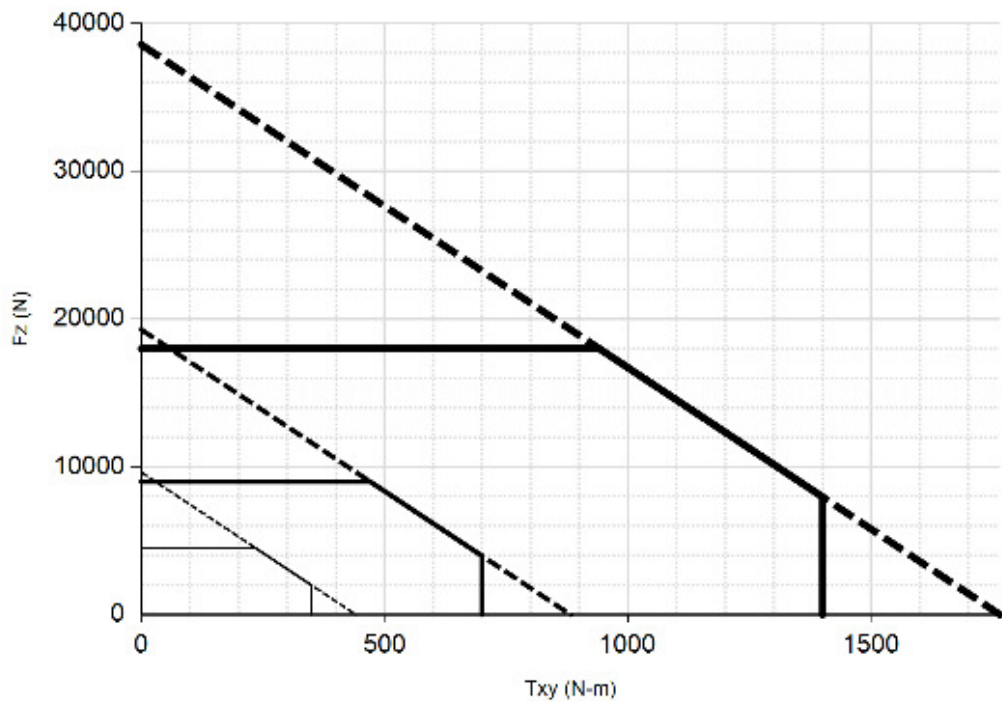
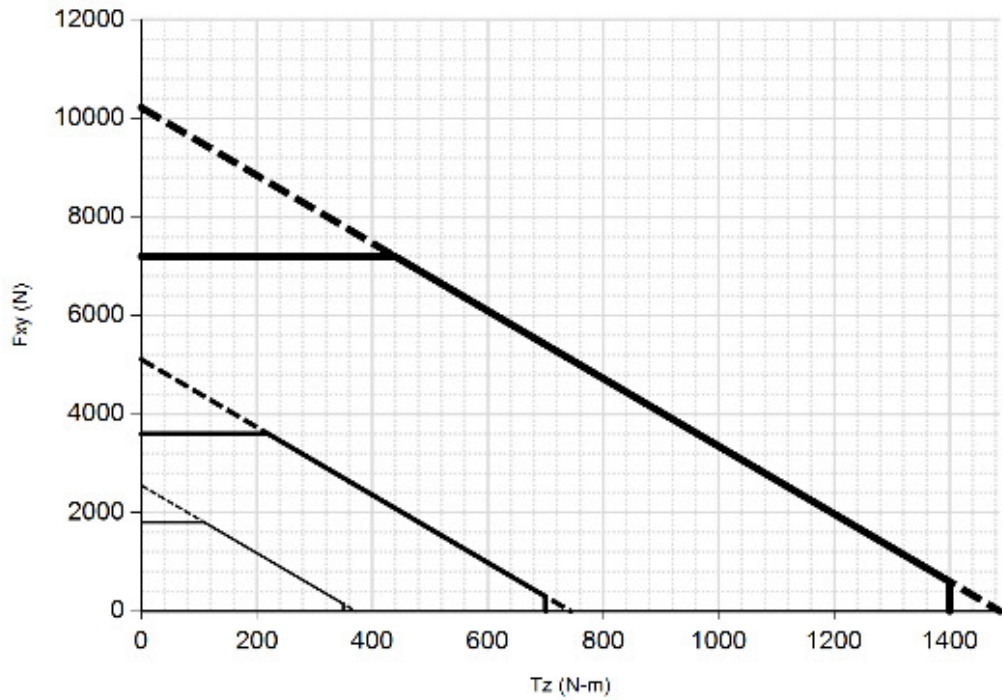

SI-1800-350
 SI-3600-700
 SI-7200-1400

*** For IP68 version see caution on physical properties page.

4.13.6 Omega190 Transducer

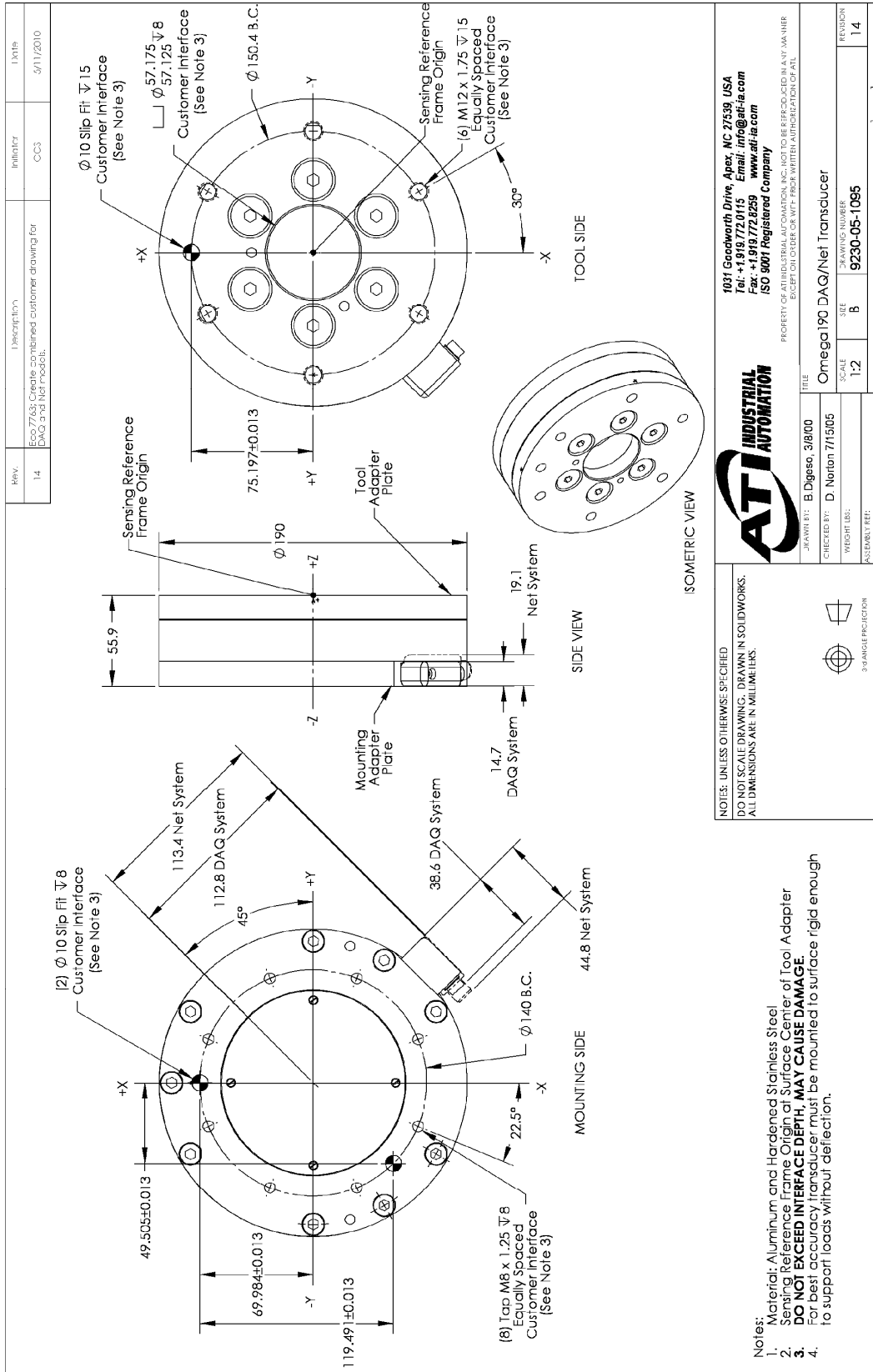

4.13.7 Omega190 IP60 Transducer

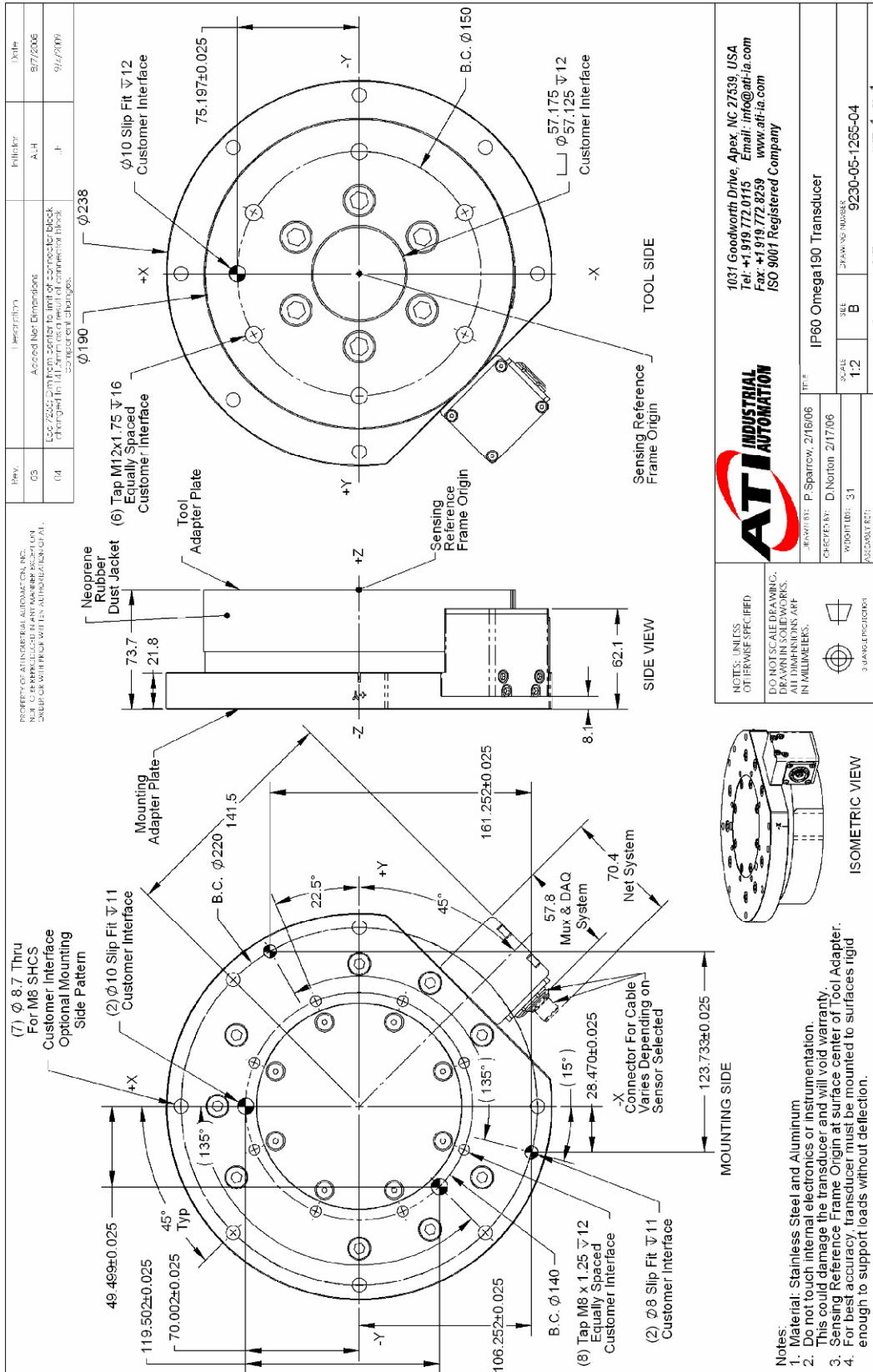

ATI INDUSTRIAL AUTOMATION

1031 Goodworth Drive, Apex, NC 27539, USA
 Tel: +1 919 772 0115 Email: info@ati-ia.com
 Fax: +1 919 772 8259 www.ati-ia.com
 ISO 9001 Registered Company

IP60 Omega190 Transducer

REVISED BY: P. Sparrow, 2/16/06
 CHECKED BY: D. Norton, 2/17/06
 WORK ID: 31
 SCALE: 1:2
 SHEET: B
 DRAWING NUMBER: 9230-05-1295-04
 PRODUCT RELEASE #

DATE: SHEET 1 OF 1

NOTES: UNLESS OTHERWISE SPECIFIED, DRAWN IN SOLIDWORKS. ALL DIMENSIONS ARE IN MILLIMETERS.

3-ANGLE PICTORIAL

4.13.8 Omega190 IP65 Transducer

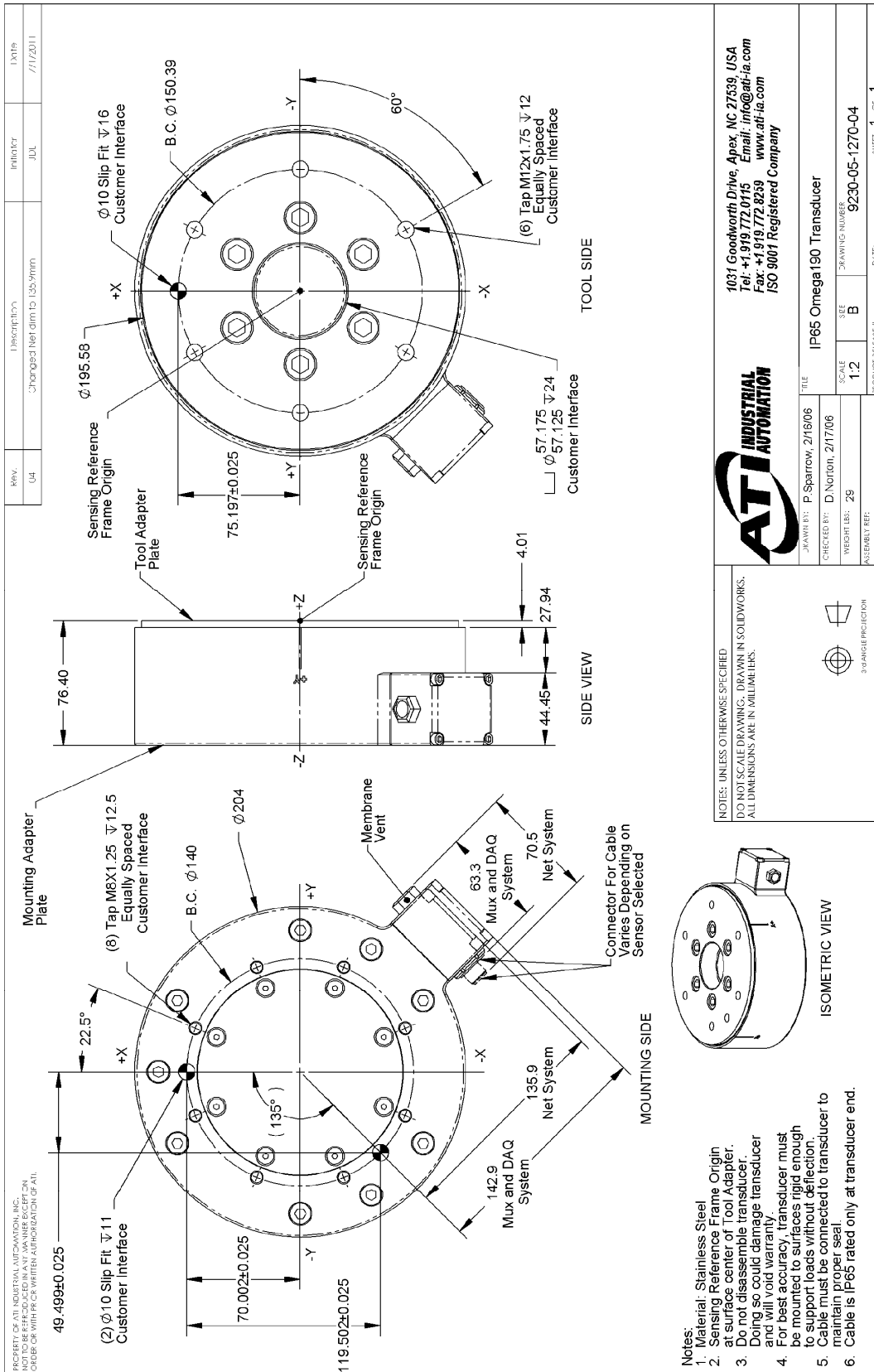

4.13.9 Omega190 IP68 Transducer

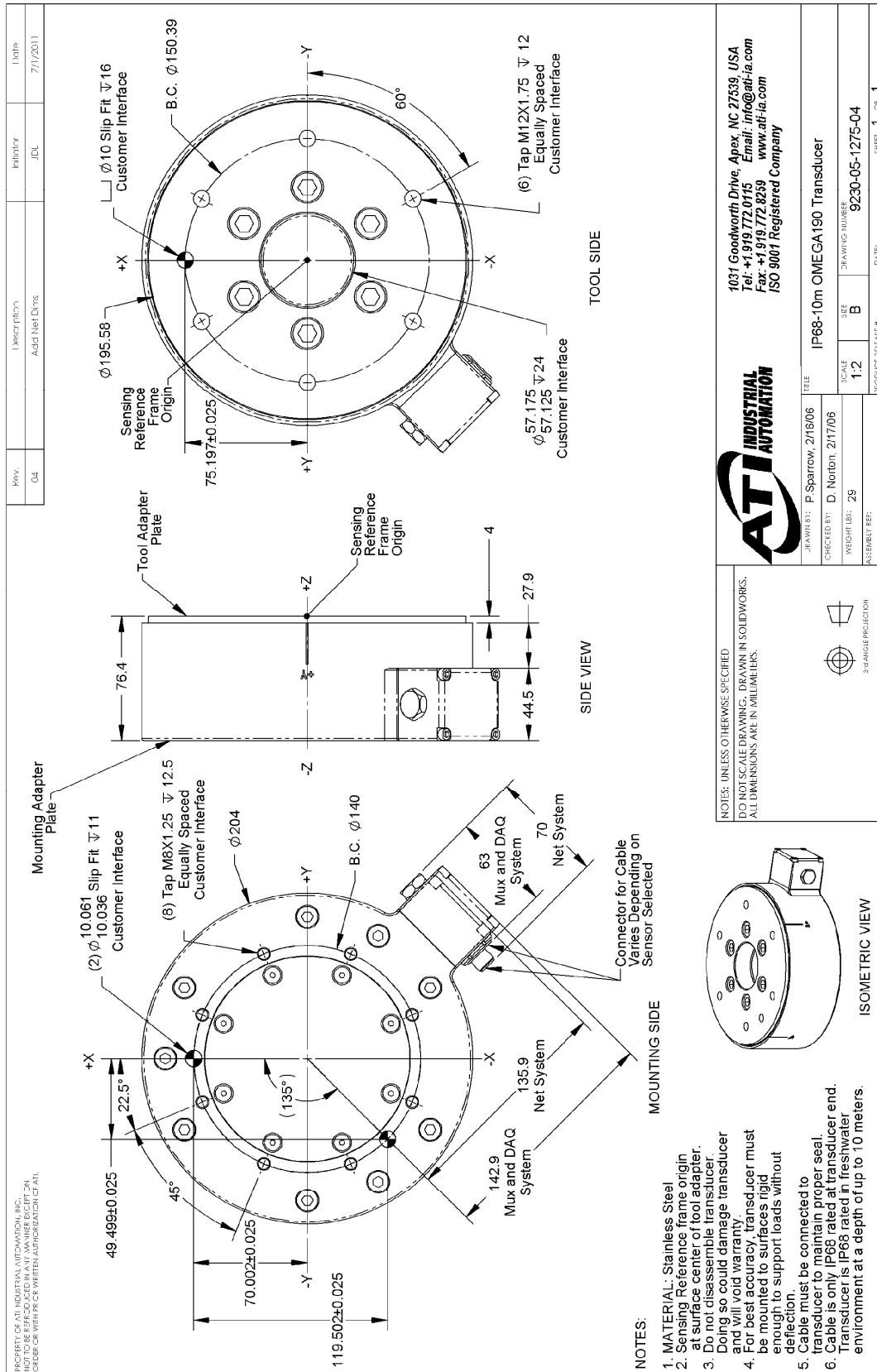

4.14 Omega250 (Includes IP60/IP65/IP68 Versions)

4.14.1 Calibration Specifications (excludes CTL calibrations)

US (English)

Calibration	F _x ,F _y	F _z ^{***}	T _x ,T _y	T _z	F _x ,F _y	F _z ^{***}	T _x ,T _y	T _z
US-900–4500	900 lbf	1800 lbf	4500 lbf-in	4500 lbf-in	1/2 lbf	1/2 lbf	1 lbf-in	1 lbf-in
US-1800–9000	1800 lbf	3600 lbf	9000 lbf-in	9000 lbf-in	1 lbf	1 lbf	2 lbf-in	2 lbf-in
US-3600–18000	3600 lbf	7200 lbf	18000 lbf-in	18000 lbf-in	2 lbf	2 lbf	5 lbf-in	5 lbf-in
	SENSING RANGES				RESOLUTION*			

SI (Metric)

Calibration	F _x ,F _y	F _z ^{***}	T _x ,T _y	T _z	F _x ,F _y	F _z ^{***}	T _x ,T _y	T _z
SI-4000–500	4000 N	8000 N	500 Nm	500 Nm	1 N	2 N	1/8 Nm	1/8 Nm
SI-8000–1000	8000 N	16000 N	1000 Nm	1000 Nm	2 N	4 N	1/4 Nm	1/4 Nm
SI-16000–2000	16000 N	32000 N	2000 Nm	2000 Nm	5 N	10 N	1/2 Nm	1/2 Nm
	SENSING RANGES				RESOLUTION*			

* DAQ resolutions are typical for a 16-bit data acquisition system.

These system resolutions quoted are the effective resolution after dropping four counts of noise. The effective resolution can be improved with filtering. NOTE: Applied loads must be within range in each of the six axes for the F/T sensor to measure correctly.

4.14.2 CTL Calibration Specifications

US (English)

Calibration	Fx,Fy	Fz***	Tx,Ty	Tz	Fx,Fy	Fz***	Tx,Ty	Tz
US-900–4500	900 lbf	1800 lbf	4500 lbf-in	4500 lbf-in	1 lbf	1 lbf	2 lbf-in	2 lbf-in
US-1800–9000	1800 lbf	3600 lbf	9000 lbf-in	9000 lbf-in	2 lbf	2 lbf	5 lbf-in	5 lbf-in
US-3600–18000	3600 lbf	7200 lbf	18000 lbf-in	18000 lbf-in	5 lbf	5 lbf	10 lbf-in	10 lbf-in
SENSING RANGES					RESOLUTION			

SI (Metric)

Calibration	Fx,Fy	Fz***	Tx,Ty	Tz	Fx,Fy	Fz***	Tx,Ty	Tz
SI-4000–500	4000 N	8000 N	500 Nm	500 Nm	2 N	4 N	1/4 Nm	1/4 Nm
SI-8000–1000	8000 N	16000 N	1000 Nm	1000 Nm	5 N	10 N	1/2 Nm	1/2 Nm
SI-16000–2000	16000 N	32000 N	2000 Nm	2000 Nm	10 N	20 N	1 Nm	1 Nm
SENSING RANGES					RESOLUTION			

US (English)

Calibration	Fx,Fy	Fz†	Tx,Ty, Tz	Fx,Fy	Fz†	Tx,Ty, Tz
US-900–4500	±900 lbf	±1800 lbf	±4500 lbf-in	90 lbf/V	180 lbf/V	450 lbf-in/V
US-1800–9000	±1800 lbf	±3600 lbf	±9000 lbf-in	180 lbf/V	360 lbf/V	900 lbf-in/V
US-3600–18000	±3600 lbf	±7200 lbf	±18000 lbf-in	360 lbf/V	720 lbf/V	1800 lbf-in/V
Analog Output Range				Analog ±10V Sensitivity‡		

SI (Metric)

Calibration	Fx,Fy	Fz†	Tx,Ty, Tz	Fx,Fy	Fz†	Tx,Ty, Tz
SI-4000–500	±4000 N	±8000 N	±500 Nm	400 N/V	900 N/V	50 Nm/V
SI-8000–1000	±8000 N	±16000 N	±1000 Nm	800 N/V	1600 N/V	100 Nm/V
SI-16000–2000	±16000 N	±32000 N	±2000 Nm	1600 N/V	3200 N/V	200 Nm/V
Analog Output Range				Analog ±10V Sensitivity‡		

Counts Value

Calibration	Fx, Fy, Fz	Tx, Ty, Tz	Fx, Fy, Fz	Tx, Ty, Tz
US-900–4500 / SI-4000–500	8 / lbf	4 / lbf-in	4 / N	32 / Nm
US-1800–9000 / SI-8000–1000	4 / lbf	2 / lbf-in	2 / N	16 / Nm
US-3600–18000 / SI-16000-2000	2 / lbf	1 / lbf-in	1 / N	8 / Nm
Tool Transform Factor	0.02 in/unit		1.25 mm/unit	
	Counts Value – US (English)		Counts Value – SI (Metric)	

CTL resolutions are typical. System resolutions quoted are the effective resolution after dropping eight counts of noise. The effective resolution can be improved with filtering. NOTE: Applied loads must be within range in each of the six axes for the F/T sensor to measure correctly.

† For IP68 version see caution on physical properties page.

‡ ±5V Sensitivity values are double the listed ±10V Sensitivity values.

**4.14.3 Omega250 Physical Properties (Includes IP60/IP65/IP68 Versions)
US (English)**

Single-Axis Overload	
Fxy	±37000 lbf
Fz	±74000 lbf
Txy	±180000 lbf-in
Tz	±220000 lbf-in
Stiffness (Calculated)	
X-axis & Y-axis forces (Kx, Ky)	2.4x10 ⁶ lb/in
Z-axis force (Kz)	3.2x10 ⁶ lb/in
X-axis & Y-axis torque (Ktx, Kty)	2.7x10 ⁷ lbf-in/rad
Z-axis torque (Ktz)	5.5x10 ⁷ lbf-in/rad
Resonant Frequency (Measured)	
Fx, Fy, Tz	N/A
Fz, Tx, Ty	N/A
Physical Specifications	
Weight*	70 lb
Diameter*	10 in
Height*	3.7 in

SI (Metric)

Single-Axis Overload	
Fxy	±160000 N
Fz	±330000 N
Txy	±21000 Nm
Tz	±25000 Nm
Stiffness (Calculated)	
X-axis & Y-axis forces (Kx, Ky)	4.2x10 ⁸ N/m
Z-axis force (Kz)	5.6x10 ⁸ N/m
X-axis & Y-axis torque (Ktx, Kty)	3.0x10 ⁶ Nm/rad
Z-axis torque (Ktz)	6.2x10 ⁶ Nm/rad
Resonant Frequency (Measured)	
Fx, Fy, Tz	N/A
Fz, Tx, Ty	N/A
Physical Specifications	
Weight*	31.8 kg
Diameter*	260 mm
Height*	95 mm

* Specifications include standard interface plates.



CAUTION:

IP68 Omega250 Fz as a Function of Submersion Depth:

When submerged, IP68 transducers exhibit a decrease in Fz range related to the submersion depth. This loss is the result of pressure-induced preloading on the transducer. The preload can be masked by biasing the transducer at the depth prior to applying the load to be measured. The following estimates are for room temperature fresh water at seal level.

IP68 Omega250	US	Metric
Fz preload at 10m depth	-1138 lb	-5061 N
Fz preload at other depths	-35 lb/ft × depthInFeet	-506 N/m × depthInMeters

**4.14.4 Omega250 (US Calibration Complex Loading)
 (Includes IP60/IP65/IP68 Versions)**

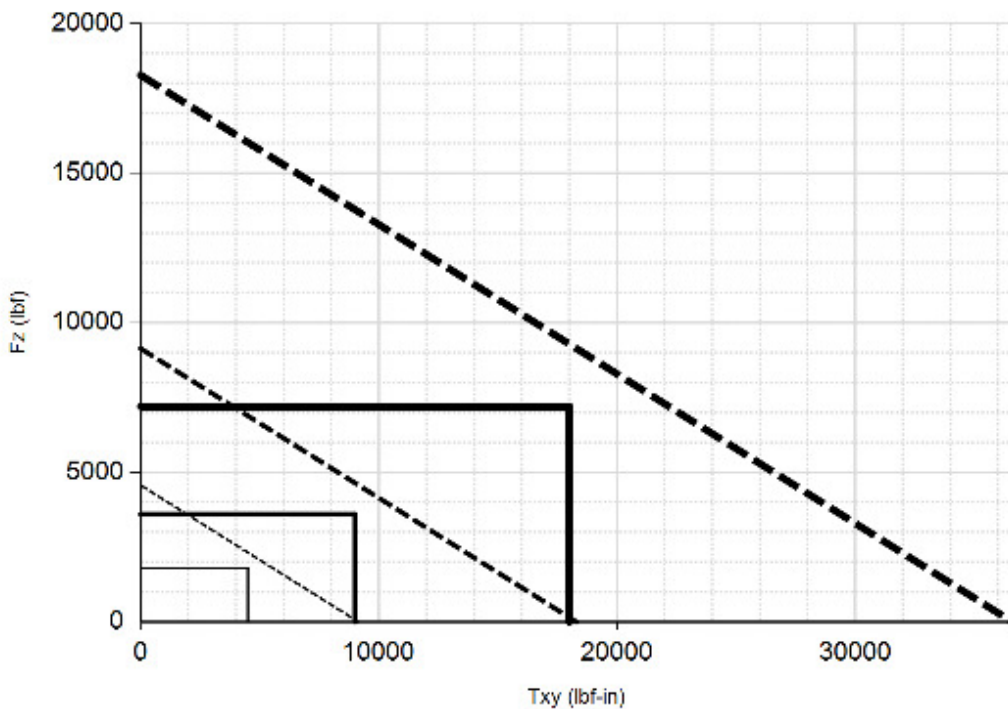
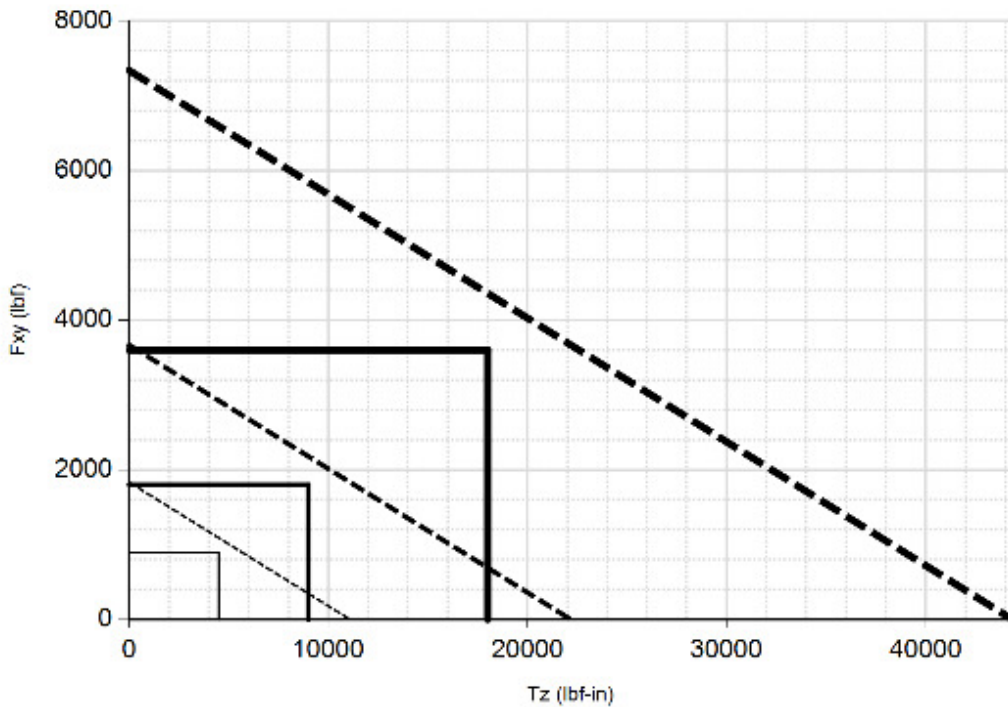

——— US-900-4500
——— US-1800-9000
——— US-3600-18000

*** For IP68 version see caution on physical properties page.

**4.14.5 Omega250 (SI Calibration Complex Loading)
 (Includes IP60/IP65/IP68 Versions)**

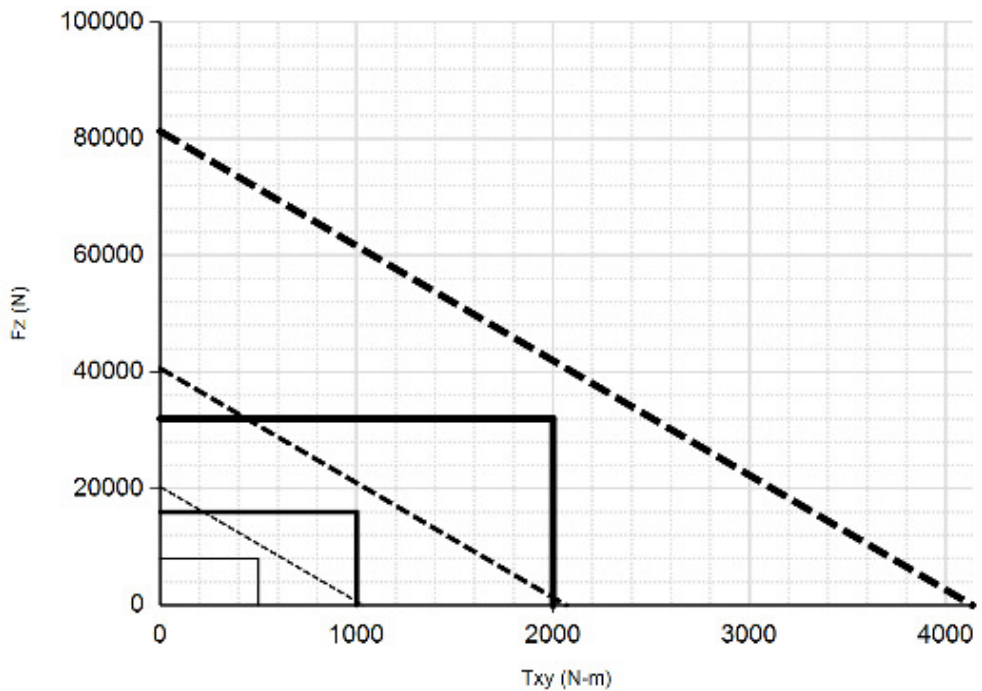
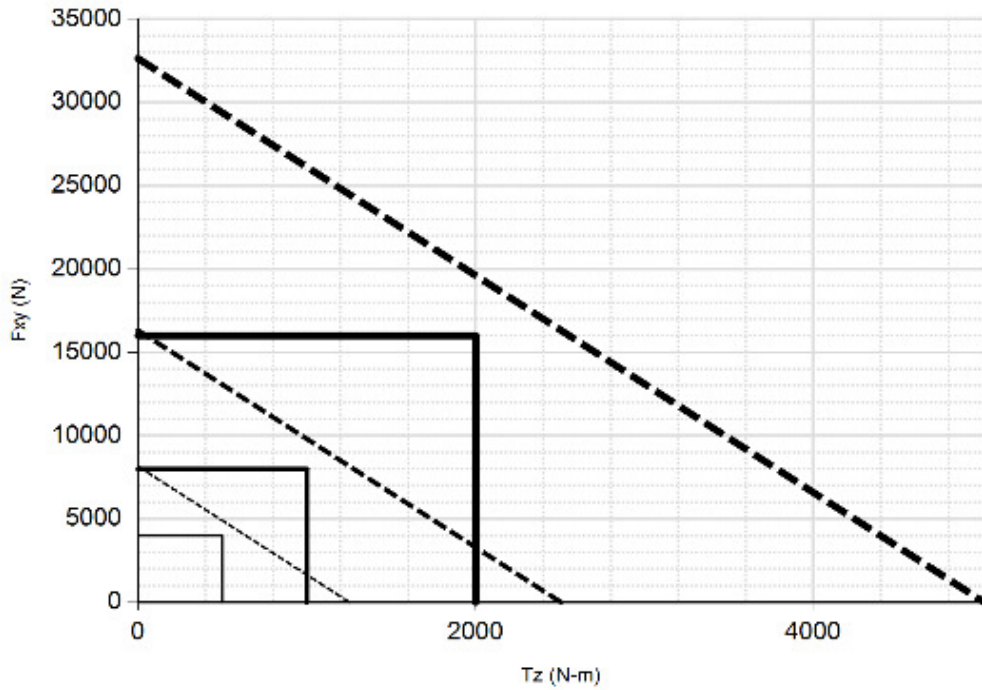

— SI-4000-500 — SI-8000-1000 — SI-16000-2000

*** For IP68 version see caution on physical properties page.

4.14.6 Omega250 IP60 Transducer

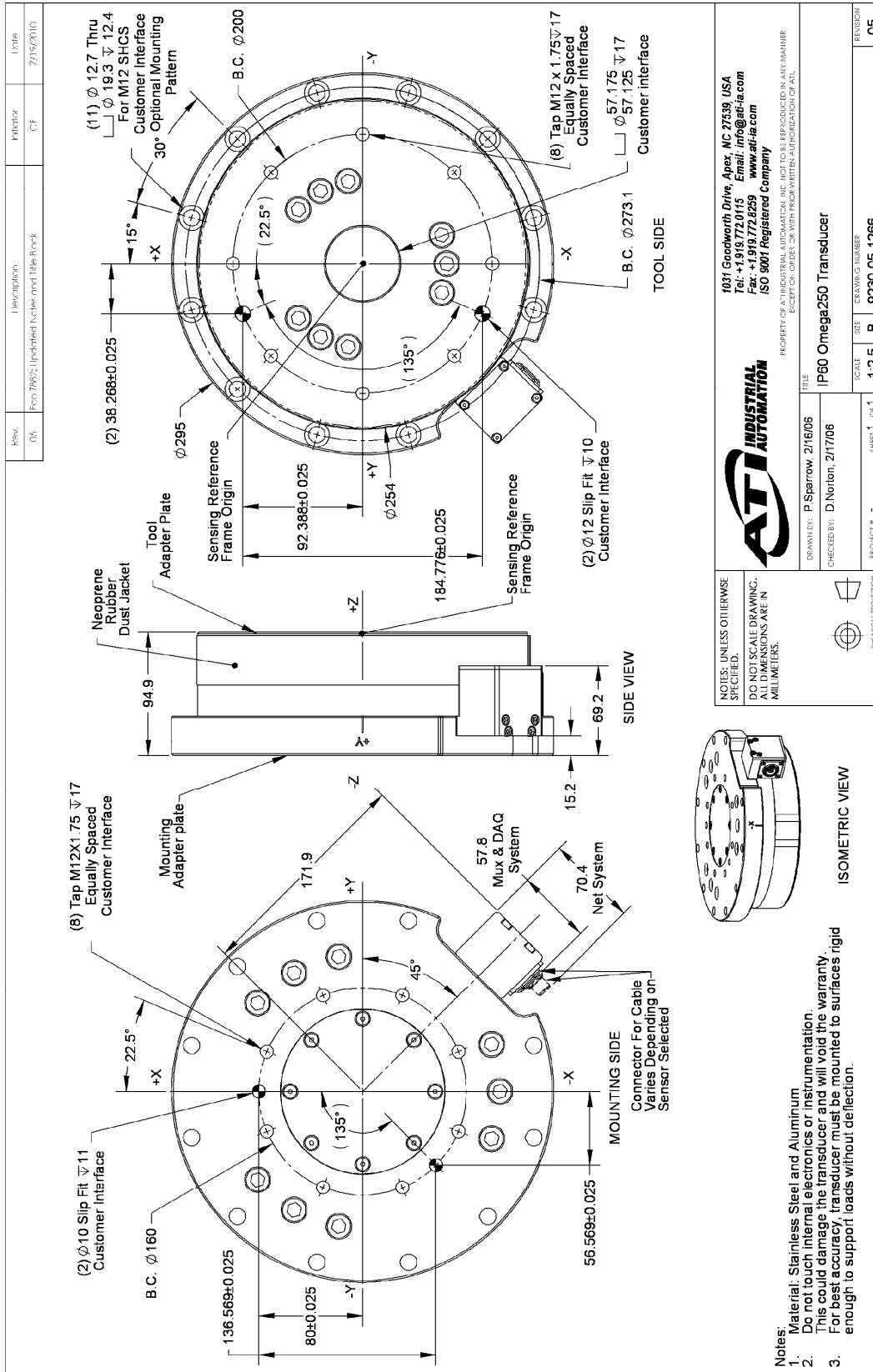

REV.	Description	INDICATOR	DATE
05	For 9620; Updated header and title block.	CF	7/15/2010

		1031 Goodworth Drive, Apex, NC 27539, USA Tel: +1.919.772.0115 Email: info@ati-ia.com Fax: +1.919.772.8259 www.ati-ia.com ISO 9001 Registered Company	
TITLE IP60 Omega250 Transducer		DRAWN BY: P. Sparrow, 2/16/05 CHECKED BY: D. Norlem, 2/17/06	
SCALE 1:2.5		SHEET # OF 1 B	
PROJECT #		DRAWING NUMBER 9230-05-1266	
SHEET # OF 1 B		REVISION 05	

4.14.7 Omega250 IP65 Transducer

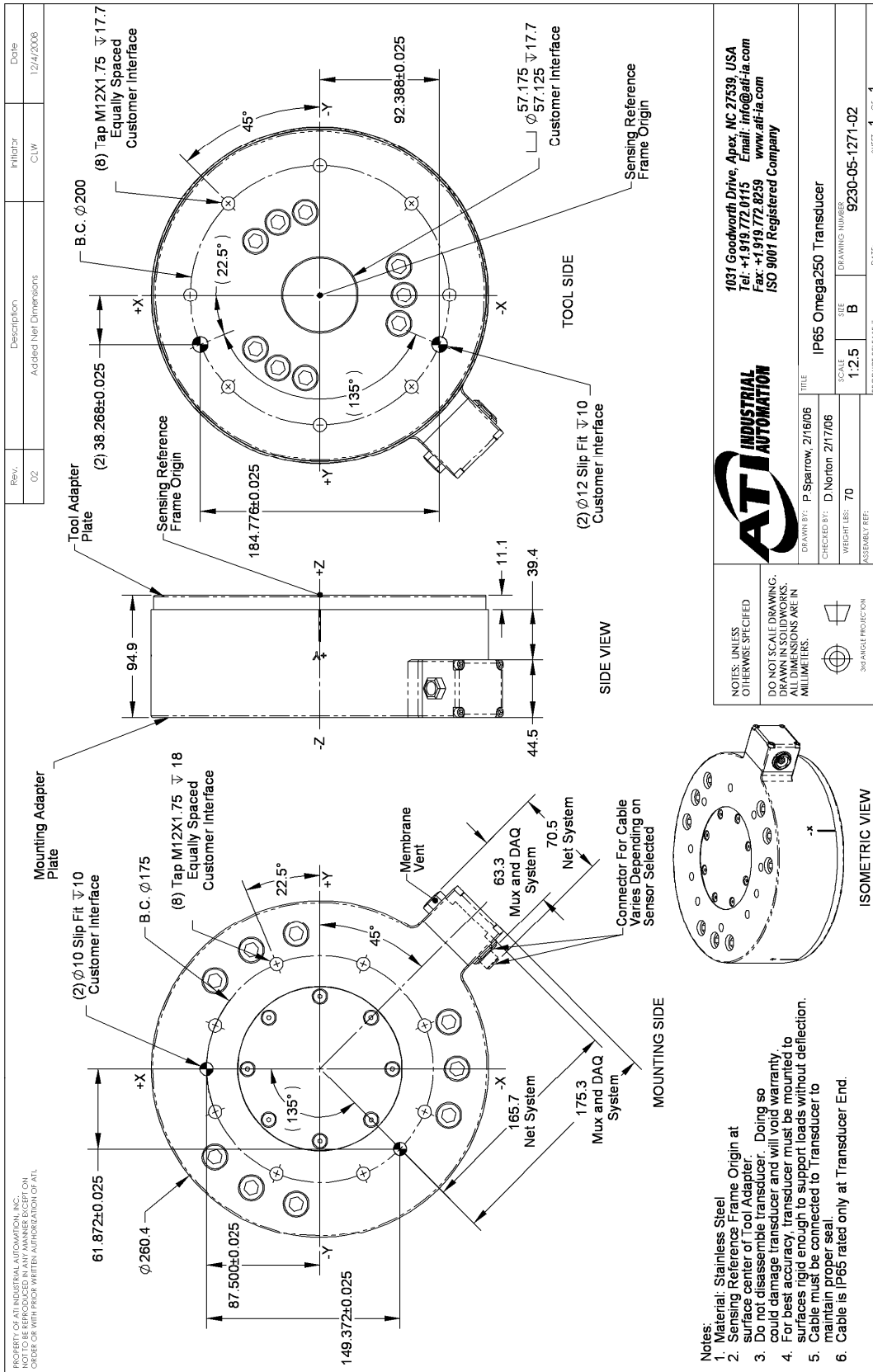

4.14.8 Omega250 IP68 Transducer

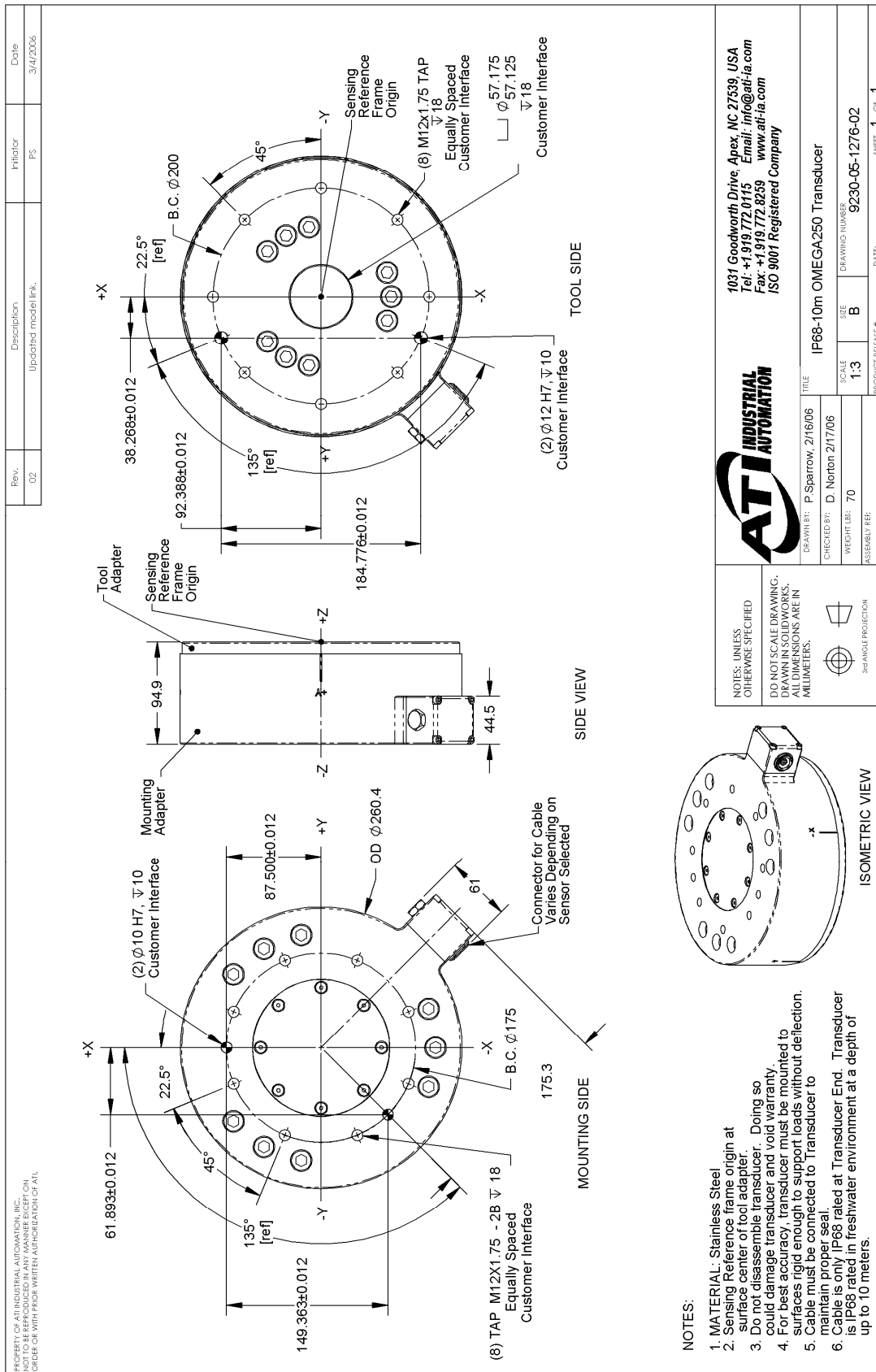

4.15 Omega331

4.15.1 Calibration Specifications (excludes CTL calibrations)

US (English)

Calibration	Fx,Fy	Fz	Tx,Ty	Tz	Fx,Fy	Fz	Tx,Ty	Tz
US-2250–13000	2250 lbf	5250 lbf	13000 lbf-in	13000 lbf-in	1/2 lbf	1 lbf	3 3/4 lbf-in	1 7/8 lbf-in
US-4500–26000	4500 lbf	10500 lbf	26000 lbf-in	26000 lbf-in	1 lbf	2 lbf	7 1/2 lbf-in	3 3/4 lbf-in
US-9000–52000	9000 lbf	21000 lbf	52000 lbf-in	52000 lbf-in	2 lbf	4 lbf	15 lbf-in	7 1/2 lbf-in
	SENSING RANGES				RESOLUTION*			

SI (Metric)

Calibration	Fx,Fy	Fz	Tx,Ty	Tz	Fx,Fy	Fz	Tx,Ty	Tz
SI-10000–1500	10 kN	22 kN	1.5 kNm	1.5 kNm	1/480 kN	1/240 kN	3/8000 kNm	3/16000 kNm
SI-20000–3000	20 kN	44 kN	3 kNm	3 kNm	1/240 kN	1/120 kN	3/4000 kNm	3/8000 kNm
SI-40000–6000	40 kN	88 kN	6 kNm	6 kNm	1/120 kN	1/60 kN	3/2000 kNm	3/4000 kNm
	SENSING RANGES				RESOLUTION*			

* DAQ resolutions are typical for a 16-bit data acquisition system.

These system resolutions quoted are the effective resolution after dropping four counts of noise. The effective resolution can be improved with filtering. NOTE: Applied loads must be within range in each of the six axes for the F/T sensor to measure correctly.

4.15.2 CTL Calibration Specifications

US (English)

Calibration	Fx,Fy	Fz	Tx,Ty	Tz	Fx,Fy	Fz	Tx,Ty	Tz
US-2250–13000	2250 lbf	5250 lbf	13000 lbf-in	13000 lbf-in	1 lbf	2 lbf	7 1/2 lbf-in	3 3/4 lbf-in
US-4500–26000	4500 lbf	10500 lbf	26000 lbf-in	26000 lbf-in	2 lbf	4 lbf	15 lbf-in	7 1/2 lbf-in
US-9000–52000	9000 lbf	21000 lbf	52000 lbf-in	52000 lbf-in	4 lbf	8 lbf	30 lbf-in	15 lbf-in
SENSING RANGES				RESOLUTION				

SI (Metric)

Calibration	Fx,Fy	Fz	Tx,Ty	Tz	Fx,Fy	Fz	Tx,Ty	Tz
SI-10000–1500	10 kN	22 kN	1.5 kNm	1.5 kNm	1/240 kN	1/120 kN	3/4000 kNm	3/8000 kNm
SI-20000–3000	20 kN	44 kN	3 kNm	3 kNm	1/120 kN	1/60 kN	3/2000 kNm	3/4000 kNm
SI-40000–6000	40 kN	88 kN	6 kNm	6 kNm	1/60 kN	1/30 kN	3/1000 kNm	3/2000 kNm
SENSING RANGES				RESOLUTION				

US (English)

Calibration	Fx,Fy	Fz	Tx,Ty, Tz	Fx,Fy	Fz	Tx,Ty, Tz
US-2250–13000	±2250 lbf	±5250 lbf	±13000 lbf-in	225 lbf/V	525 lbf/V	1300 lbf-in/V
US-4500–26000	±4500 lbf	±10500 lbf	±26000 lbf-in	450 lbf/V	1050 lbf/V	2600 lbf-in/V
US-9000–52000	±9000 lbf	±21000 lbf	±52000 lbf-in	900 lbf/V	2100 lbf/V	5200 lbf-in/V
Analog Output Range			Analog ±10V Sensitivity‡			

SI (Metric)

Calibration	Fx,Fy	Fz	Tx,Ty, Tz	Fx,Fy	Fz	Tx,Ty, Tz
SI-10000–1500	±10 kN	±22 kN	±1.5 kNm	1 kN/V	2.2 kN/V	0.15 kNm/V
SI-20000–3000	±20 kN	±44 kN	±3 kNm	2 kN/V	4.4 kN/V	0.3 kNm/V
SI-40000–6000	±40 kN	±88 kN	±6 kNm	4 kN/V	8.8 kN/V	0.6 kNm/V
Analog Output Range			Analog ±10V Sensitivity‡			

Counts Value

Calibration	Fx, Fy, Fz	Tx, Ty, Tz	Fx, Fy, Fz	Tx, Ty, Tz
US-2250–13000 / SI-10000–1500	32 / lbf	6.4 / lbf-in	7680 / kN	64000 / kNm
US-4500–26000 / SI-20000–3000	16 / lbf	3.2 / lbf-in	3840 / kN	32000 / kNm
US-9000–52000 / SI-40000–6000	8 / lbf	1.6 / lbf-in	1920 / kN	16000 / kNm
Tool Transform Factor	0.05 in/unit		1.2 mm/unit	
Counts Value – US (English)			Counts Value – SI (Metric)	

CTL resolutions are typical. System resolutions quoted are the effective resolution after dropping eight counts of noise. The effective resolution can be improved with filtering. NOTE: Applied loads must be within range in each of the six axes for the F/T sensor to measure correctly.

‡ ±5V Sensitivity values are double the listed ±10V Sensitivity values.

**4.15.3 Omega331 Physical Properties (Includes IP60/IP65/IP68 Versions)
US (English)**

Single-Axis Overload	
Fxy	±58000 lbf
Fz	±120000 lbf
Txy	±280000 lbf-in
Tz	±410000 lbf-in
Stiffness (Calculated)	
X-axis & Y-axis forces (Kx, Ky)	6.9x10 ⁶ lb/in
Z-axis force (Kz)	7.3x10 ⁶ lb/in
X-axis & Y-axis torque (Ktx, Kty)	8.1x10 ⁷ lbf-in/rad
Z-axis torque (Ktz)	2.1x10 ⁸ lbf-in/rad
Resonant Frequency (Measured)	
Fx, Fy, Tz	N/A
Fz, Tx, Ty	N/A
Physical Specifications	
Weight*	104 lb
Diameter*	13 in
Height*	4.3 in

SI (Metric)

Single-Axis Overload	
Fxy	±260000 N
Fz	±520000 N
Txy	±32000 Nm
Tz	±46000 Nm
Stiffness (Calculated)	
X-axis & Y-axis forces (Kx, Ky)	1.2x10 ⁹ N/m
Z-axis force (Kz)	1.3x10 ⁹ N/m
X-axis & Y-axis torque (Ktx, Kty)	9.2x10 ⁶ Nm/rad
Z-axis torque (Ktz)	2.4x10 ⁷ Nm/rad
Resonant Frequency (Measured)	
Fx, Fy, Tz	N/A
Fz, Tx, Ty	N/A
Physical Specifications	
Weight*	47 kg
Diameter*	330 mm
Height*	110 mm

* Specifications include standard interface plates.

4.15.4 Omega331 (US Calibration Complex Loading)

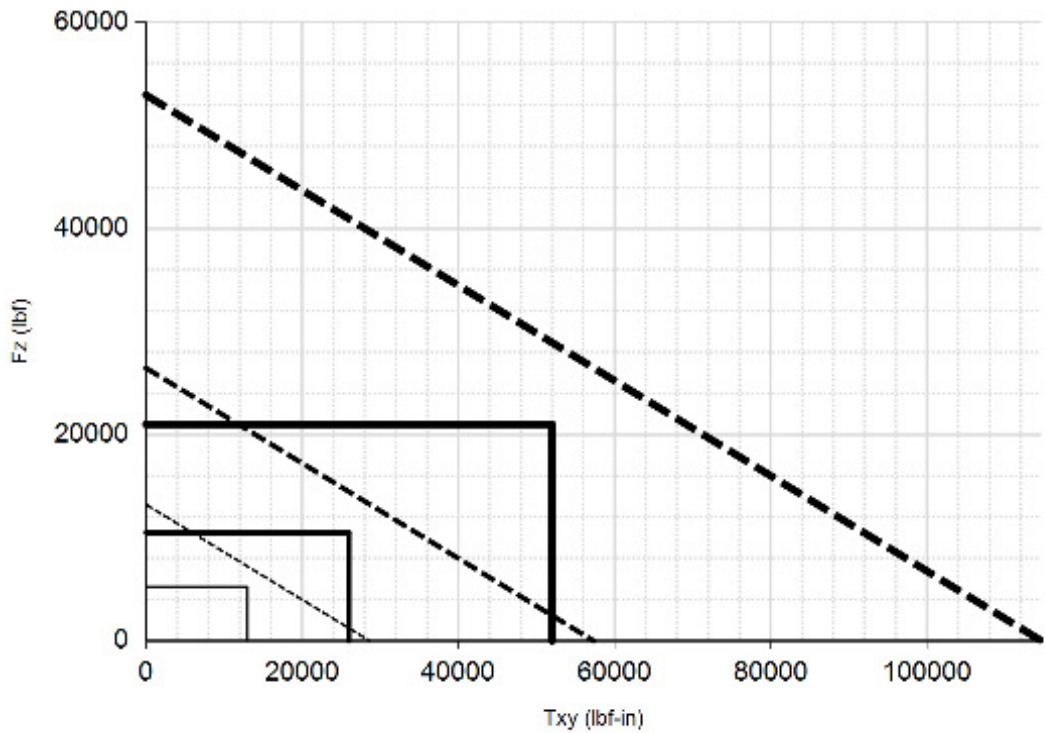
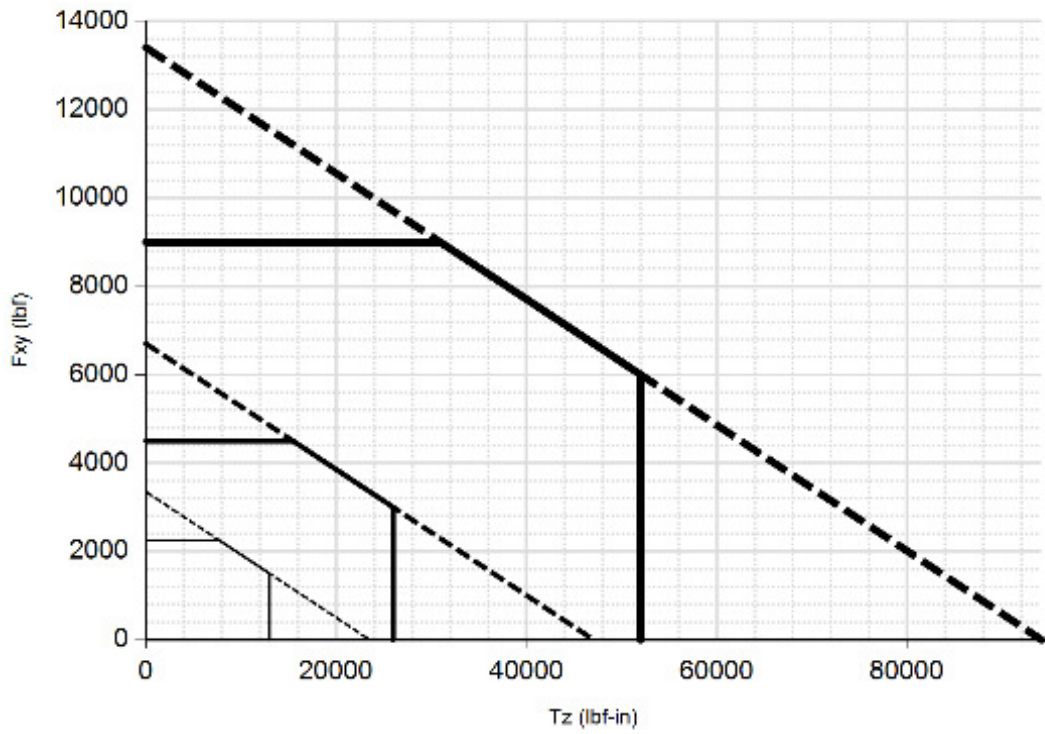

US-2250-13000
 US-4500-26000
 US-9000-52000

4.15.5 Omega331 (SI Calibration Complex Loading)

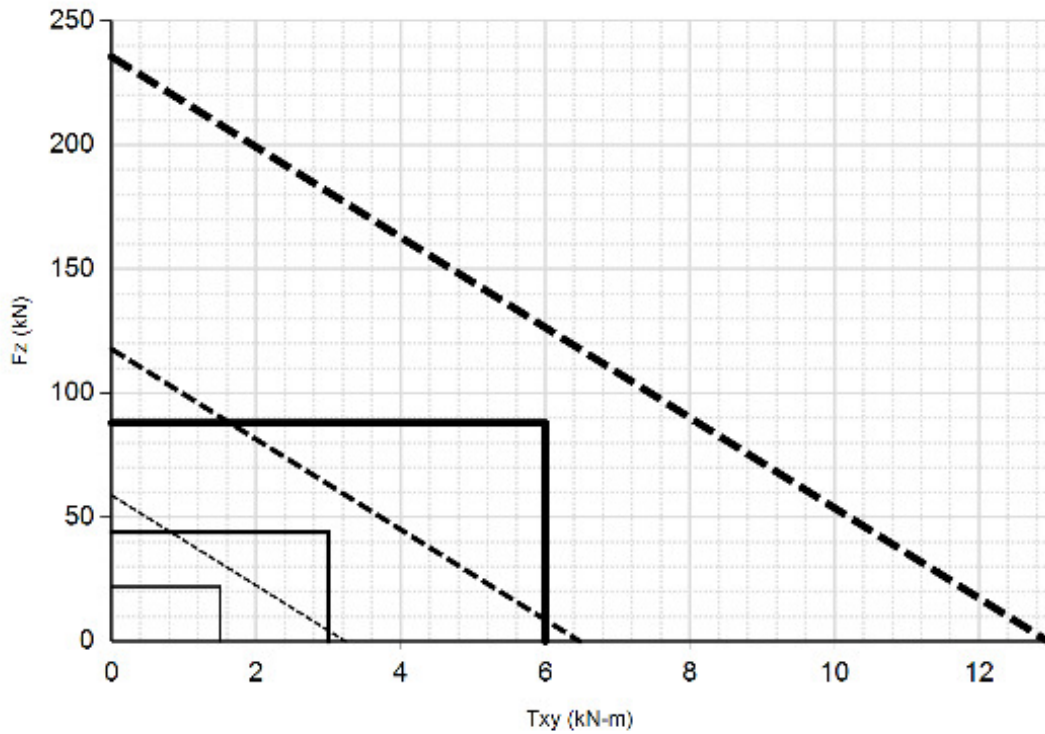
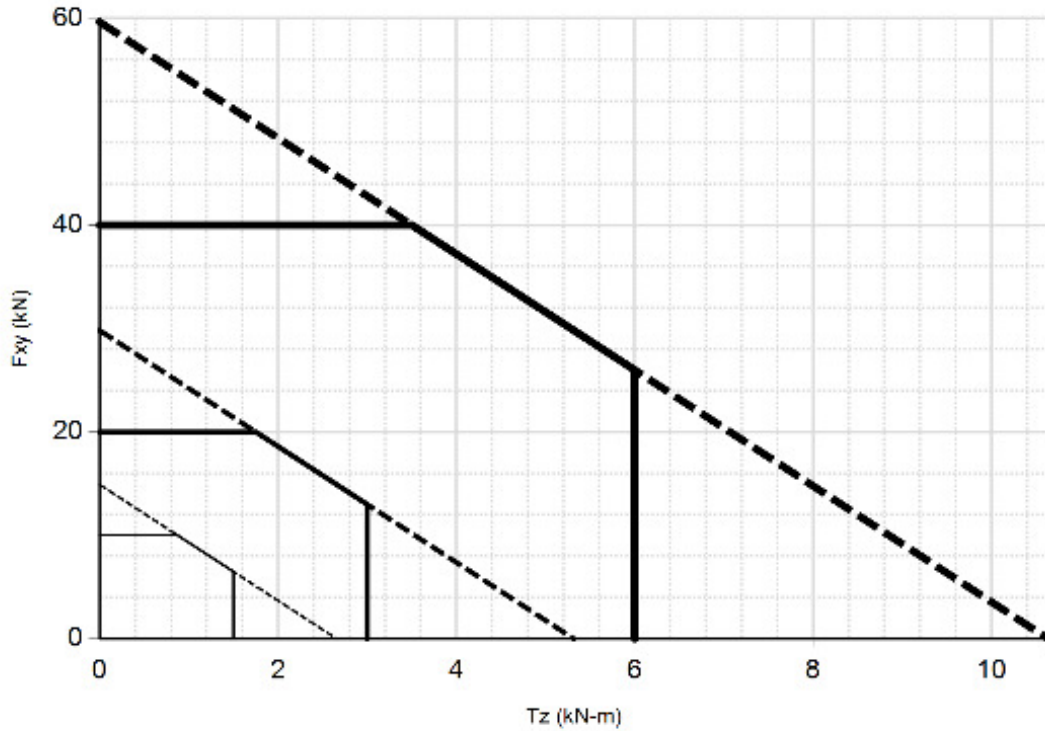

—— SI-10000-1500
—— SI-20000-3000
—— SI-40000-6000

4.15.6 Omega331 Transducer

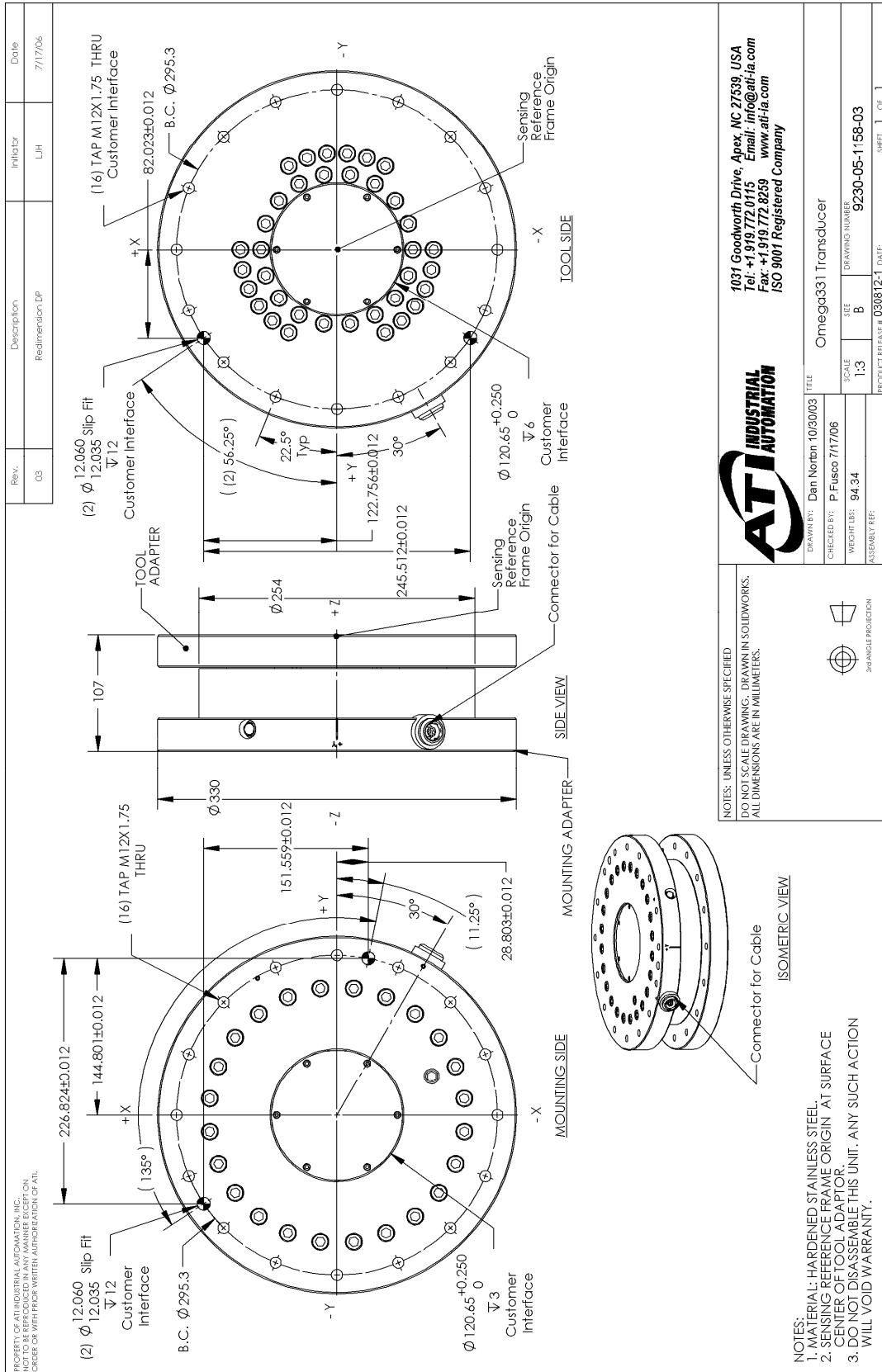

ATI INDUSTRIAL AUTOMATION

1031 Goodworth Drive, Apex, NC 27539, USA
 Tel: +1.919.772.0115 Email: info@ati-ia.com
 Fax: +1.919.772.8259 www.ati-ia.com
 ISO 9001 Registered Company

DRAWN BY: Dan Norton 10/30/03
 CHECKED BY: P.Fusco 7/17/06
 WEIGHT LBS: 94.34
 ASSEMBLY REF:

TITLE: Omega331 Transducer
 SCALE: 1:3
 SIZE: B
 DRAWING NUMBER: 9230-05-1158-03
 PRODUCT RELEASE # 030812-1 DATE:

SHEET 1 OF 1

5. Advanced Topics

5.1 Reducing Noise

5.1.1 Mechanical Vibration

In many cases, perceived noise is actually a real fluctuation of force and/or torque, caused by vibrations in the tooling or the robot arm. Many F/T systems offer filtering or averaging that can smooth out noise. If this is not sufficient, you may want to add a digital filter to the application software.

5.1.2 Electrical Interference

Check the F/T's ground connections if you observe interference by motors or other noise-generating equipment.

Consider using averaging or filtering if sufficient grounding is not possible or does not reduce the noise.

5.2 Detecting Failures (Diagnostics)

5.2.1 Detecting Sensitivity Changes

Sensitivity checking of the transducer can also be used to measure the transducer system's health. This is done by applying known loads to the transducer and verifying the system output matches the known loads. For example, a transducer mounted to a robot arm may have an end-effector attached to it:

1. If the end-effector has moving parts, they must be moved in a known position. Place the robot arm in an orientation that allows the gravity load from the end-effector to exert load on many transducer output axes.
2. Record the output readings.
3. Position the robot arm to apply another load, this time causing the outputs to move far from the earlier readings.
4. Record the second set of output readings.
5. Find the differences from the first and second set of readings and use it as your sensitivity value.

Even if the values vary somewhat from sample set to sample set, they can be used to detect gross errors. Either the resolved outputs or the raw transducer voltages may be used (the same must be used for all steps of this process).



CAUTION: When any strain gage output is saturated or otherwise inoperable, all transducer F/T readings are invalid. Therefore, it is vitally important to monitor for these conditions.

5.3 Scheduled Maintenance

5.3.1 Periodic Inspection

For most applications, there are no parts that need to be replaced during normal operation. With industrial-type applications that continuously or frequently move the system's cabling, you should periodically check the cable jacket for signs of wear. These applications should implement the procedures discussed in *Section 5.2—Detecting Failures (Diagnostics)* to detect any failures.

Transducers that are not IP60, IP65, or IP68 rated must be kept free of excessive dust, debris, or moisture. IP60-rated transducers must be kept free of excessive moisture. Debris and dust should be kept from accumulating on or in a transducer.

5.3.2 Periodic Calibration

Periodic calibration of the transducer and its electronics is required to maintain traceability to national standards. Follow any applicable ISO-9000-type standards for calibration. ATI Industrial Automation recommends annual recalibrations, especially for applications that frequently cycle the loads applied to the transducer.

5.4 Transducer Cabling

5.4.1 Calibrations

In many cases the transducer cable comprises part of the calibrated transducer. In these cases, changing the length or type of the cable can affect the calibration. Check with ATI Industrial Automation when making cabling changes to ensure your system's calibration will not be affected.

5.4.2 Connectors

The transducer cables and connectors are not designed to be user serviceable. The high flex life stranding used in the cable is difficult to work with and will fail prematurely if improperly assembled.

However, there are special cases when customers find it necessary to temporarily remove the connector on a cable that is permanently attached to a transducer (such as found on the Nano and Mini series transducers). When reattaching the wires to the connector, it is vital that each conductor is encased in heat shrink tubing at the connection to prevent premature fatiguing of the mechanical connection. Also, any components contained in the connector must be reconnected exactly as found – failing to do so will impact system performance and accuracy.

5.5 A Word about Resolution

ATI's transducers have a three sensing beam configuration where the three beams are equally spaced around a central hub and attached to the outside wall of the transducer. This design transfers applied loads to multiple sensing beams and allows the transducer to increase its sensing range in a given axis if a counterpart axis has reduced.

The resolution of each transducer axis depends on how the applied load is spread among the sensing beams. The best resolution occurs in the scenario when the quantization of the gages is evenly distributed as load is applied. In the worst case scenario, the discrete value of all involved gages increases at the same time. The typical scenario will be somewhere between these two.

F/T resolutions are specified as *typical resolution*, defined as the average of the worst and best case scenarios. Because both multi-gage effects can be modeled as a normal distribution, this value represents the most commonly perceived, average resolution. Although this misrepresents the actual performance of the transducers, it results in a close (and always conservative) estimate.

6. Terms and Conditions of Sale

The following Terms and Conditions are a supplement to and include a portion of ATI's Standard Terms and Conditions, which are on file at ATI and available upon request.

ATI warrants to Purchaser that force torque sensor products purchased hereunder will be free from defects in material and workmanship under normal use for a period of one year from the date of shipment. This warranty does not cover components subject to wear and tear under normal usage or those requiring periodic replacement. ATI will have no liability under this warranty unless: (a) ATI is given written notice of the claimed defect and a description thereof within thirty (30) days after Purchaser discovers the defect and in any event not later than the last day of the warranty period; and (b) the defective item is received by ATI not later ten (10) days after the last day of the warranty period. ATI's entire liability and Purchaser's sole remedy under this warranty is limited to repair or replacement, at ATI's election, of the defective part or item or, at ATI's election, refund of the price paid for the item. The foregoing warranty does not apply to any defect or failure resulting from improper installation, operation, maintenance or repair by anyone other than ATI.

ATI will in no event be liable for incidental, consequential or special damages of any kind, even if ATI has been advised of the possibility of such damages. ATI's aggregate liability will in no event exceed the amount paid by purchaser for the item which is the subject of claim or dispute. ATI will have no liability of any kind for failure of any equipment or other items not supplied by ATI.

No action against ATI, regardless of form, arising out of or in any way connected with products or services supplied hereunder may be brought more than one year after the cause of action accrued.

No representation or agreement varying or extending the warranty and limitation of remedy provisions contained herein is authorized by ATI, and may not be relied upon as having been authorized by ATI, unless in writing and signed by an executive officer of ATI.

Unless otherwise agreed in writing by ATI, all designs, drawings, data, inventions, software and other technology made or developed by ATI in the course of providing products and services hereunder, and all rights therein under any patent, copyright or other law protecting intellectual property, shall be and remain ATI's property. The sale of products or services hereunder does not convey any express or implied license under any patent, copyright or other intellectual property right owned or controlled by ATI, whether relating to the products sold or any other matter, except for the license expressly granted below.

In the course of supplying products and services hereunder, ATI may provide or disclose to Purchaser confidential and proprietary information of ATI relating to the design, operation or other aspects of ATI's products. As between ATI and Purchaser, ownership of such information, including without limitation any computer software provided to Purchaser by ATI, shall remain in ATI and such information is licensed to Purchaser only for Purchaser's use in operating the products supplied by ATI hereunder in Purchaser's internal business operations.

Without ATI's prior written permission, Purchaser will not use such information for any other purpose or provide or otherwise make such information available to any third party. Purchaser agrees to take all reasonable precautions to prevent any unauthorized use or disclosure of such information.

Purchaser will not be liable hereunder with respect to disclosure or use of information which: (a) is in the public domain when received from ATI; (b) is thereafter published or otherwise enters the public domain through no fault of Purchaser; (c) is in Purchaser's possession prior to receipt from ATI; (d) is lawfully obtained by Purchaser from a third party entitled to disclose it; or (f) is required to be disclosed by judicial order or other governmental authority, provided that, with respect to such required disclosures, Purchaser gives ATI prior notice thereof and uses all legally available means to maintain the confidentiality of such information.