

1.2.1 Photodiode Energy Sensors

10pJ to 15μJ

Features

- Silicon and Germanium detectors
- Very sensitive - down to 10pJ
- Repetition rates to 10kHz
- Wide spectral range

PD10 / PD10-pJ / PD10-IR-pJ



Model	PD10	PD10-pJ	PD10-IR-pJ																												
Use	Low energies	Lowest energies	Infrared																												
Aperture mm	φ10	φ10	φ 5																												
Absorber Type	Si photodiode with attenuator	Si photodiode	Ge photodiode																												
Spectral Range μm ^(a)	0.19 - 1.1	0.2 - 1.1	0.7 - 1.8																												
Surface Reflectivity % approx.	50	30	30																												
Calibration Accuracy +/- % ^(a)	5	5	5																												
Energy Scales	20μJ to 20nJ	200nJ to 200pJ	20nJ to 200pJ																												
Lowest Measurable Energy nJ	2 at 900nm	0.01 at 900nm	0.03 at 900nm																												
Max Pulse Width ms	0.005	0.005	0.005																												
Maximum Pulse Rate pps	10kHz	10kHz	10kHz																												
Noise on Lowest Range nJ	0.2	0.002	0.010																												
Additional Error with Frequency %	±1% to 10kHz	±1% to 10kHz	±1.5% to 10kHz																												
Linearity with Energy for > 10% of full scale	±1%	±1%	±1%																												
Damage Threshold J/cm ²	0.1	0.1	0.1																												
Maximum Average Power mW	50 at 800nm	0.5	0.5																												
Maximum Average Power Density W/cm ²	50	5	5																												
Maximum Energy vs. Wavelength	<table border="1"> <thead> <tr> <th>Wavelength</th> <th>Maximum Energy</th> </tr> </thead> <tbody> <tr> <td><300nm</td> <td>15μJ</td> </tr> <tr> <td>350-550nm</td> <td>8μJ</td> </tr> <tr> <td>>800nm</td> <td>5μJ</td> </tr> </tbody> </table>	Wavelength	Maximum Energy	<300nm	15μJ	350-550nm	8μJ	>800nm	5μJ	<table border="1"> <thead> <tr> <th>Wavelength</th> <th>Maximum Energy</th> </tr> </thead> <tbody> <tr> <td><300nm</td> <td>150nJ</td> </tr> <tr> <td>350-550nm</td> <td>75nJ</td> </tr> <tr> <td>>800nm</td> <td>50nJ</td> </tr> </tbody> </table>	Wavelength	Maximum Energy	<300nm	150nJ	350-550nm	75nJ	>800nm	50nJ	<table border="1"> <thead> <tr> <th>Wavelength</th> <th>Maximum Energy</th> </tr> </thead> <tbody> <tr> <td>800 - 900nm</td> <td>20nJ</td> </tr> <tr> <td>1000 - 1300nm</td> <td>8nJ</td> </tr> <tr> <td>1300 - 1400nm</td> <td>7nJ</td> </tr> <tr> <td>1480 - 1560nm</td> <td>6nJ</td> </tr> <tr> <td>>1650nm</td> <td>20nJ</td> </tr> </tbody> </table>	Wavelength	Maximum Energy	800 - 900nm	20nJ	1000 - 1300nm	8nJ	1300 - 1400nm	7nJ	1480 - 1560nm	6nJ	>1650nm	20nJ
Wavelength	Maximum Energy																														
<300nm	15μJ																														
350-550nm	8μJ																														
>800nm	5μJ																														
Wavelength	Maximum Energy																														
<300nm	150nJ																														
350-550nm	75nJ																														
>800nm	50nJ																														
Wavelength	Maximum Energy																														
800 - 900nm	20nJ																														
1000 - 1300nm	8nJ																														
1300 - 1400nm	7nJ																														
1480 - 1560nm	6nJ																														
>1650nm	20nJ																														
Fiber Adapters Available (see page 66)	ST, FC, SMA, SC	ST, FC, SMA, SC	ST, FC, SMA, SC																												
Weight kg	0.25	0.25	0.25																												
Version	V2	V2	V2																												
Part Number	7Z02823	7Z02824	7Z02827																												
Note: (a) This is basic calibration accuracy. In certain wavelength regions calibration there is additional error as tabulated here.	<table border="1"> <tbody> <tr> <td><250nm</td> <td>add ±3%</td> </tr> <tr> <td>>950nm</td> <td>add ±2%</td> </tr> </tbody> </table>	<250nm	add ±3%	>950nm	add ±2%	<table border="1"> <tbody> <tr> <td><250nm</td> <td>add ±2%</td> </tr> <tr> <td>>950nm</td> <td>add ±2%</td> </tr> </tbody> </table>	<250nm	add ±2%	>950nm	add ±2%	<table border="1"> <tbody> <tr> <td><900nm</td> <td>add ±2%</td> </tr> <tr> <td>>1700nm</td> <td>add ±2%</td> </tr> </tbody> </table>	<900nm	add ±2%	>1700nm	add ±2%																
<250nm	add ±3%																														
>950nm	add ±2%																														
<250nm	add ±2%																														
>950nm	add ±2%																														
<900nm	add ±2%																														
>1700nm	add ±2%																														

PD10 / PD10-pJ

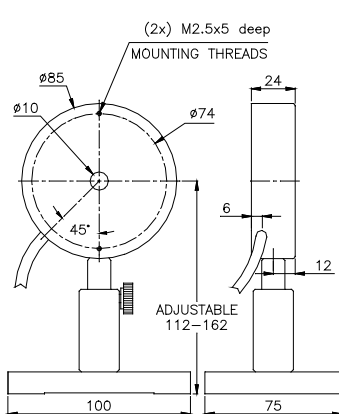

PD10-IR-pJ

