

## Description

We at Transpeutics have decided to re-design the standard vaccine carrier to enhance the function of the carrier without significantly affecting the over-all cost. Our vaccine carrier has the following novel features:

- **Single Vial Dispensing Mechanism**

We identified temperature regulation as one of the key customer needs for a new vaccine carrier design. We uncovered in our field research that frequent opening of the vaccine carrier (often in open and sunny spaces) can lead to an increase in temperature that renders the vaccine impotent. The mechanism we designed is easy to use, saves time, and also controls the temperature within the carrier. The vials are organized spatially and are distributed evenly between the ice packs, thus preventing freezing/warming of the vaccines.

- **Temperature Display, Logger and Warning System**

We identified temperature tracking as another key customer need for a new vaccine carrier design. We have developed a novel temperature tracking and logging device that will not only relay real-time temperature information to the user, but will also log the temperature such that retrospective analysis can be conducted to better uncover failures in the cold chain. A visual and audible warning system has been incorporated to indicate to the user if the temperature is crossing the standard WHO limits. A logger is also provided to continuously record the temperature changes during the vaccine delivery in the cold chain process.

- **Adaptive Straps and Modular Packing**

Finally, we identified modularity as a key customer need for vaccine carriers because of the diversity of applications of the carriers in the field. Modular packing is used so that multiple carriers can be stacked together. Additional containers (for carrying other medical supplies or for vaccine disposal) can also be attached to the carrier via this mechanism. Adaptive straps allow the user to carry the vaccine box on the shoulder or to secure the carrier to a vehicle.

## Representative Sketches & CAD Models of Selected Concepts

### **Single Vial Dispensing Mechanism: Rotating barrel dispenser**

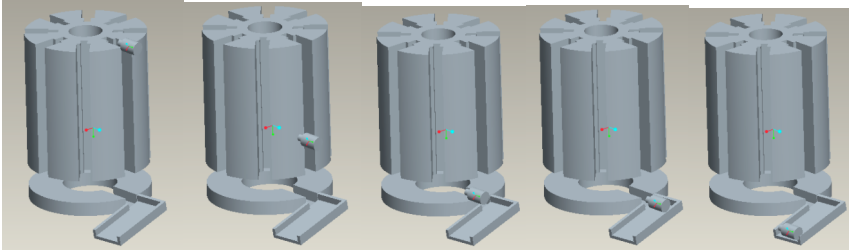
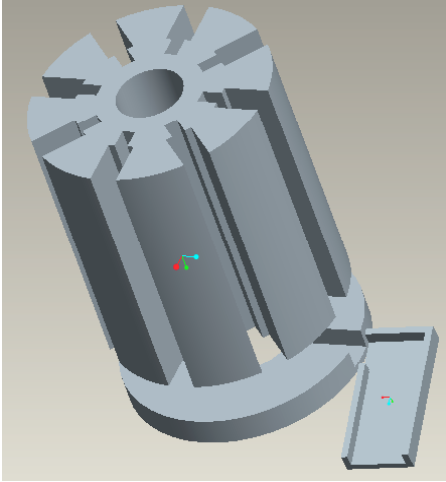

Vials are stacked in columns that can be rotated to dispense individual vials as needed. Different columns can store different vaccines, depending on the user's needs.

## Temperature Display, Logger and Warning System

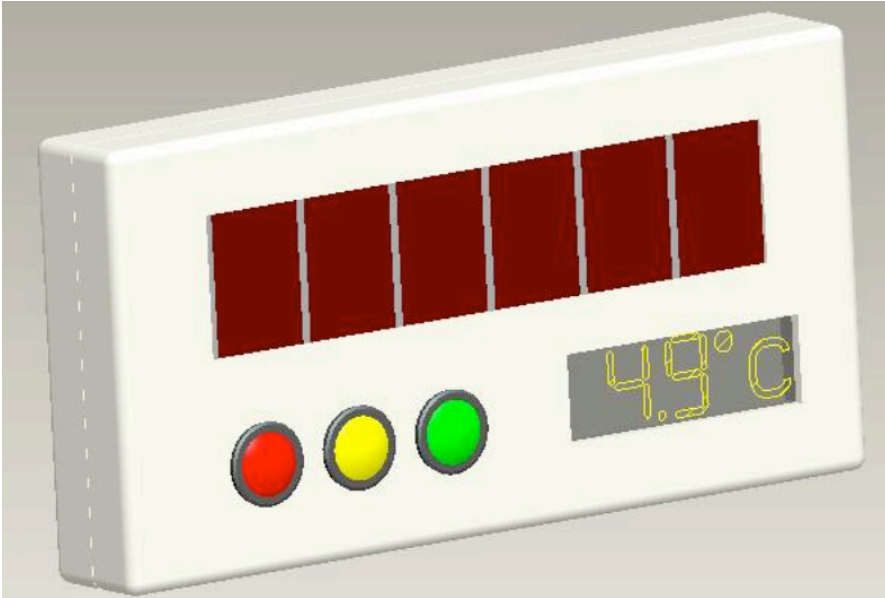

Features an LC read-out display of the temperature, LEDs that show the status of the temperature as a color read-out, and a small solar panel (plus back-up rechargeable battery) for power.

## Adaptive Straps and Modular Packing

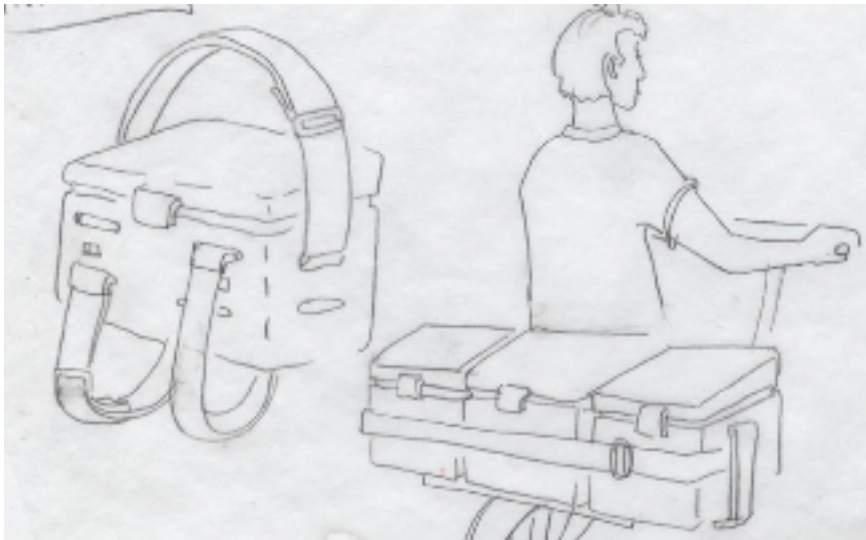
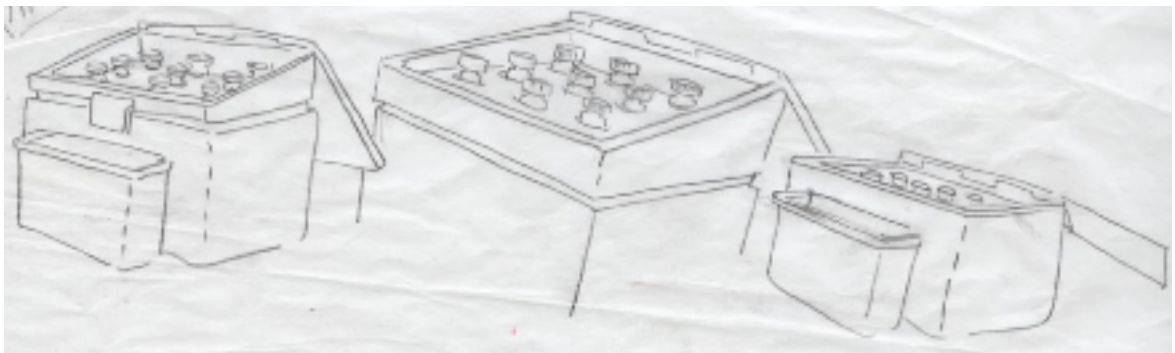
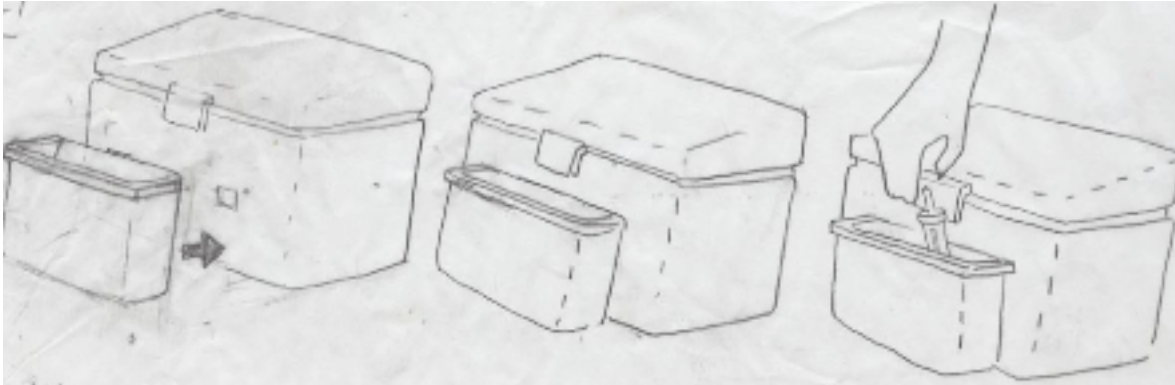

These design features will enable the user to carry vaccines in a variety of different ways depending on the conditions of use.