

Ogive Nose Cones

David Stribling
NAR 18402 Sr

The ogive nose cone is probably one of the most common shapes used in model rocketry. It exhibits very good drag characteristics for general model rocketry use. If you are building a scale Tomahawk, Sandhawk, or Phoenix, then you will be dealing with an ogive. Ogives are classified by their "caliber", or length to diameter ratio. Thus a nose that is one inch diameter and three inches long is a "3-to-1" (3:1) ogive and has a caliber of 3.

Once, while trying to build a Nike-Tomahawk, I tried to find the formula to draw a 3:1 ogive so that I could turn the cone on a lathe. I looked through Pete Alway's *The Art of Scale Model Rocketry*, engineering and math textbooks, the CRC math handbook, old rocketry magazines, and the Internet. I could not find the formulas.

I decided to derive the equations myself. Step 1: What the heck is an ogive anyway? *Webster's Ninth Collegiate Dictionary* defines "ogive" as "\'oh-,jiv\ n 1. a: a diagonal arch or rib across a Gothic vault b: a pointed arch 2: a graph each of whose ordinates represents the sum of all the frequencies up to and including a corresponding frequency in a frequency distribution".

Well, that wasn't much help! If you've seen pictures of Gothic cathedrals, you will see the pointed arches all over the place. But that doesn't explain what an ogive nose cone is! Further searching turned up an old NAR Technical Report #8: "*Ogive' me a ring-tailed cylindrical bird says G. Harry Stine*", and a description of ogive nose cones is given as follows:

"There are two basic types of ogival nose shapes: the tangent ogive and the secant ogive. A tangent ogive has an arc which meets the body contour smoothly, thereby creating no break in line where the ogive joins the cylindrical body. In other words, the center of rotation of the arc is in the plane of the base of the nose. If the center of rotation of the arc is aft of the plane of the base of the nose, you've got a secant ogive. Simple, no?"

The following diagrams illustrate what G. Harry was saying:

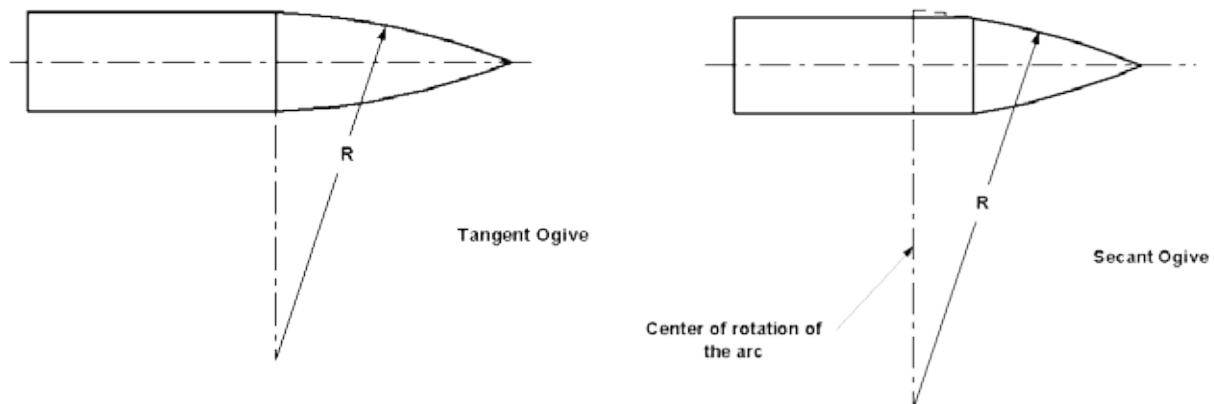

Figure 1.

Figure 2.

Using Figure 1 and Figure 3, along with some mathematical maneuvering, you can derive equation (1). As my math professors in college were so fond of saying, "the solution to that exercise will be left to the student to complete..." (or see Appendix A).

The following methods describe ways to calculate the centers and radii of the tangent, and secant ogive curves.

Tangent Ogive (numerical method)

The formula to generate a tangent ogive cone is:

$$y = \sqrt{\frac{d^2 C^2}{4} + \frac{1}{4} x^2} - \frac{d C^2}{4} - \frac{1}{4} \quad (1a)$$

where x, y are coordinates, x being along the length of the cone, and y being the "height" (or radius) of the cone taken from the centerline of the cone..

The caliber of the cone is:

$$C = \frac{L}{d} \quad (2)$$

Where:

L = cone length

d = cone base dia

A simpler approximation formula can also be used:

$$y = \frac{d}{2} - \frac{x^2}{2 L C} \quad (1b)$$

This parabolic equation produces a slightly "flatter" curve than the arc equation.

Note these equations will form 1/2 of the cone, you will need to mirror the plot to make the complete cone.

Equations 1a or 1b will provide x, y coordinates to machine a cone either manually, or by a numerical controlled (NC) lathe.

Tangent Ogive (graphical method, layout Figure 3)

This method was originally described in the Estes Technical Report TR-11: *Aerodynamic Drag of Model Rockets*, by Dr. Gerald Gregorek. In that report, the offset K and radius R were given

as constants for 3:1 and 2:1 ogive contours. To obtain similar relations for any caliber of ogive curve, see Appendix A:

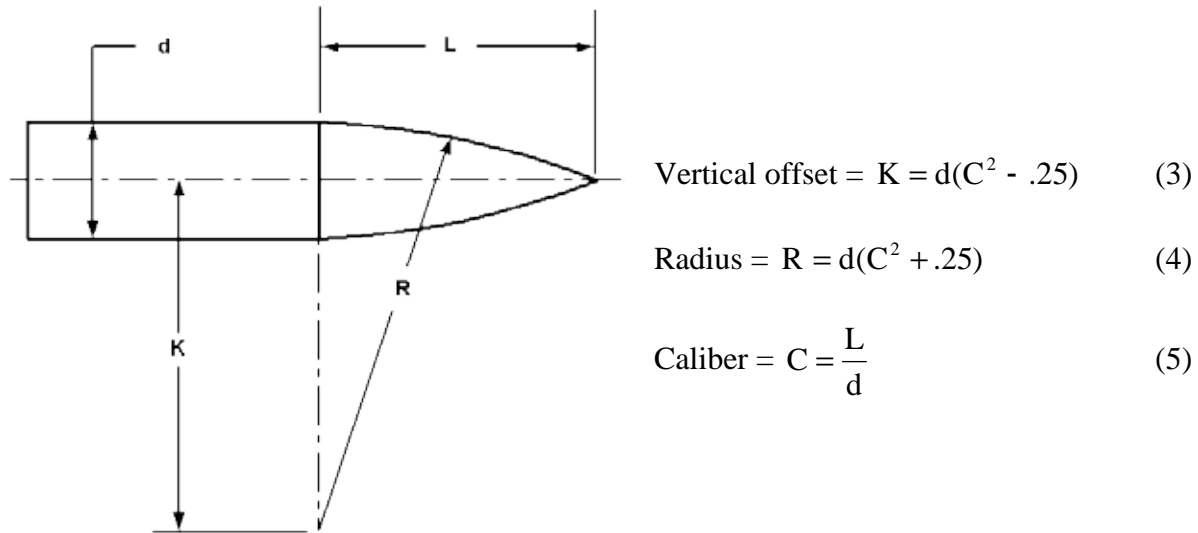

Figure 3.

Secant Ogive (Derived from existing design, such as a scale rocket blueprint)

This is more involved to create than a tangent ogive. You have to find the center of rotation of the arc and determine how far aft it is from the plane of the base of the nose (x_{off} and y_{off} in the figure below). Then you will basically have a tangent ogive at an imaginary diameter, d_2 (see layout, Figure 4).

1. Draw a line from the point of the nose to the intersection of the body tube (see close up Figure 5, below). This is called a chord, or a secant (imagine that!).
2. Find the center of the chordal length (c) and draw a perpendicular line (90 degrees) that crosses the curve of the nose cone.
3. Measure the perpendicular distance (h), and calculate the radius of the curve using the following formula:

$$r = \frac{4h^2 + c^2}{8h} \quad (6)$$

4. Now calculate the angle between the secant and the centerline of the nose (b), and the angle between the perpendicular and the radial line running from the nose tip to the center of the arc ($a/2$):

$$b = \arctan \frac{d}{2L} \quad (7)$$

$$\frac{a}{2} = \arccos \frac{\dot{e} - 4h^2 + c^2}{\dot{e}} \frac{\dot{u}}{\ddot{u}} \quad (8)$$

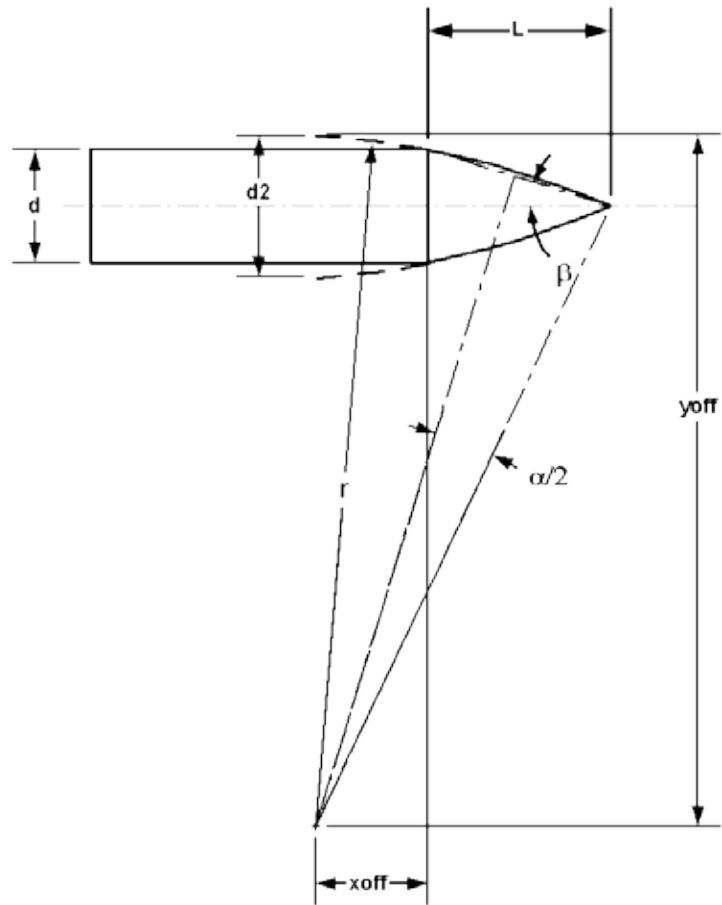

Figure 4.

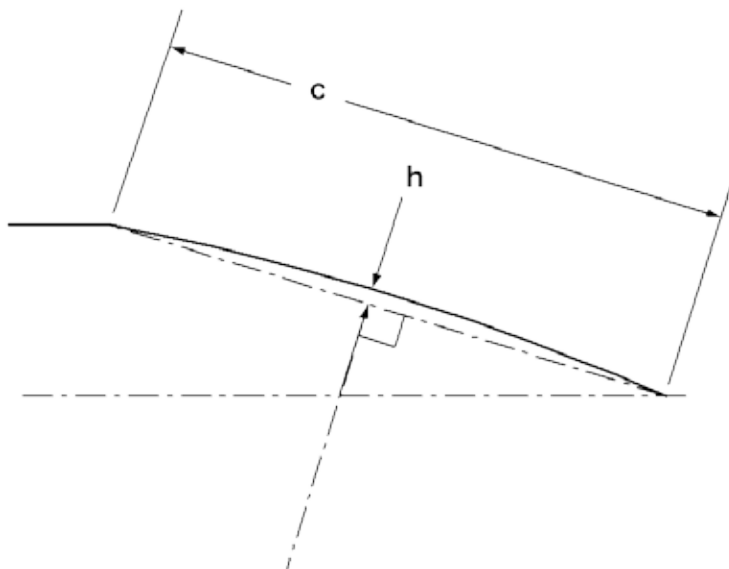

Figure 5.

5. Now calculate x_{off} and y_{off} to determine where the center of the arc is in relation to the base of the nose, and the centerline of the body:

$$x_{off} = -r' \sin \frac{\theta}{2} b + \frac{a}{2} \quad (9)$$

$$y_{off} = r' \cos \frac{\theta}{2} b + \frac{a}{2} \quad (10)$$

6. At this point, you can draw the secant ogive cone using a compass. If you want to determine the true tangent ogive diameter, use the following:

$$d_2 = d + 2(r - y_{off}) \quad (11)$$

7. Now if you want to calculate x and y coordinates for a CAD program or NC lathe, use the tangent ogive equations from above, starting at $x = x_{off}$ and use d_2 for d .

Virginia Tech has a website on aerodynamics called "[Configuration Aerodynamics Course](http://www.dept.aoe.vt.edu/~mason/Mason_f/ConfigAeroAppA.pdf)" that has a pdf file called "Geometry for Aerodynamicists". This document contains formulas for other nose shapes, such as the Von Karmen ogive. It is 79 KB, and is available at http://www.dept.aoe.vt.edu/~mason/Mason_f/ConfigAeroAppA.pdf.

David Stribling
NAR 18402 Sr.

References

1. *Ogive' me a ring-tailed cylindrical bird says G. Harry Stine*; Stine, G.H.; NAR Technical Report #8
2. *Aerodynamic Drag of Model Rockets*; Gregorek, Gerald; Estes Industries TR-11, 1970.

Appendix A Derivation of the Ogive Equation

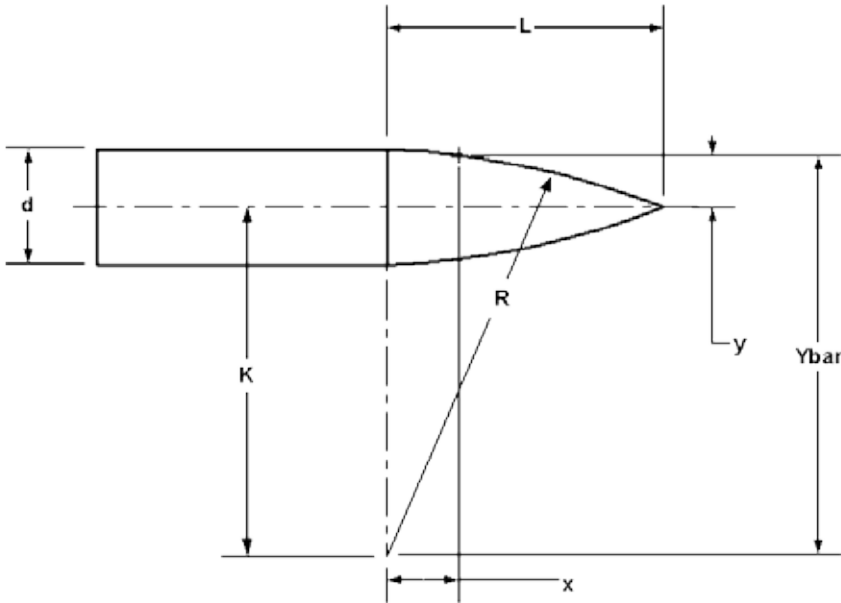

Equation of a circle

$$R^2 = x^2 + Ybar^2$$

or, $R = \sqrt{x^2 + Ybar^2}$

@ $x=0$, $Ybar = K + \frac{d}{2}$, $R_0 = \sqrt{0 + (K + \frac{d}{2})^2}$ or $R_0 = K + \frac{d}{2}$

@ $x=L$, $Ybar = K$, $R_L = \sqrt{L^2 + K^2}$

Since $R = R_0 = R_L$

$$K + \frac{d}{2} = \sqrt{L^2 + K^2}$$

Square both sides and cancel terms:

$$\left(K + \frac{d}{2}\right)^2 = L^2 + K^2$$

$$K^2 + 2K\frac{d}{2} + \frac{d^2}{4} = L^2 + K^2 \quad \text{becomes} \quad K \cdot d = L^2 - \frac{d^2}{4}$$

$$K = \frac{1}{d} \frac{\rho}{e} L^2 - \frac{d^2 \ddot{\theta}}{4 \rho}$$

Substitute caliber $C = \frac{L}{d}$ or $L = C \times d$

$$K = \frac{1}{d} \frac{\rho}{e} C^2 d^2 - \frac{d^2 \ddot{\theta}}{4 \rho}$$

Therefore $K = \frac{\rho}{e} C^2 d - \frac{1}{4} \frac{\ddot{\theta}}{\rho}$

Substitute K back into the equation for R_0

$$R = R_0 = K + \frac{d}{2}$$

$$R = \frac{\rho}{e} C^2 d - \frac{1}{4} \frac{\ddot{\theta}}{\rho} + \frac{d}{2}$$

$$R = \frac{\rho}{e} C^2 d + \frac{1}{4} \frac{\ddot{\theta}}{\rho}$$

Referring back to the figure, $y = Y_{\text{bar}} - K$

$$Y_{\text{bar}} = \sqrt{R^2 + x^2}$$

$$y = \sqrt{R^2 + x^2} - K$$

substitute K and R from above,

$$y = \sqrt{\left(\frac{\rho}{e} C^2 d + \frac{1}{4} \frac{\ddot{\theta}}{\rho}\right)^2 + x^2} - \left(\frac{\rho}{e} C^2 d + \frac{1}{4} \frac{\ddot{\theta}}{\rho}\right)$$