



# Introduction to the Ionosphere

## 2013 ISR Summer School

Elizabeth Kendall  
July 29, 2013

Major credits to: Anita Aikio, University of Oulu and Anthea Coster, MIT Haystack

# Outline

- The neutral atmosphere
- Regions of the ionosphere
- Ionospheric dynamics and ionization
- Conductivity
- Index of refraction
- Debye length
- Latitudinal and regional variations

# The neutral atmosphere

- The **troposphere** is heated by the warm ground and infrared radiation is emitted radially. T decreases with height. The **tropopause** is at 12-15 km,  $T_{\min} \sim -53\text{C}$ .
- In the **stratosphere**, the ozone ( $\text{O}_3$ ) layer at 15-40 km absorbs solar radiation. The **stratopause** is at 50 km with  $T_{\max} \sim 7\text{C}$ .
- In the **mesosphere**, heat is removed by the radiation of infrared and visible airglow as well as by eddy transport. The **mesopause** is close to 85 km with  $T_{\min} \sim -100\text{C}$ .
- In the **thermosphere**, UV radiation is absorbed and it produces dissociation of molecules and ionization of atoms and molecules.

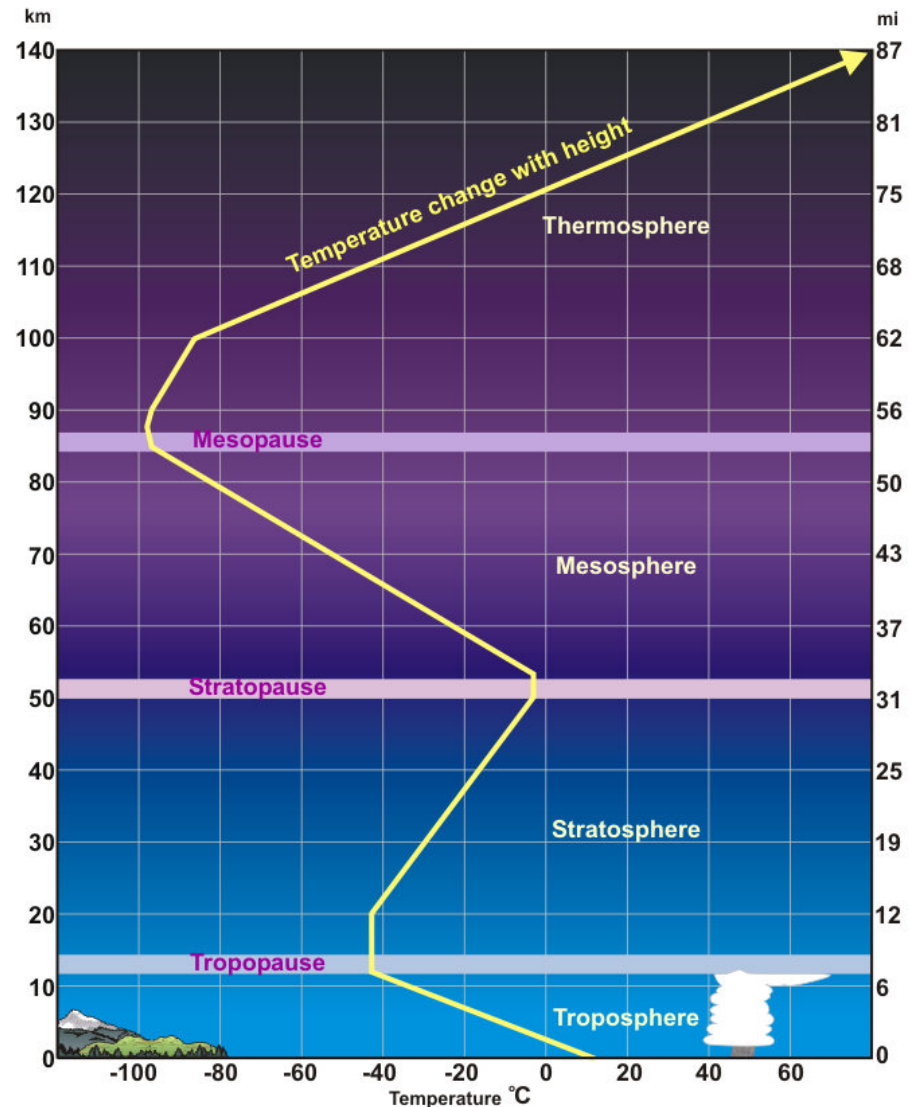

# The neutral atmosphere

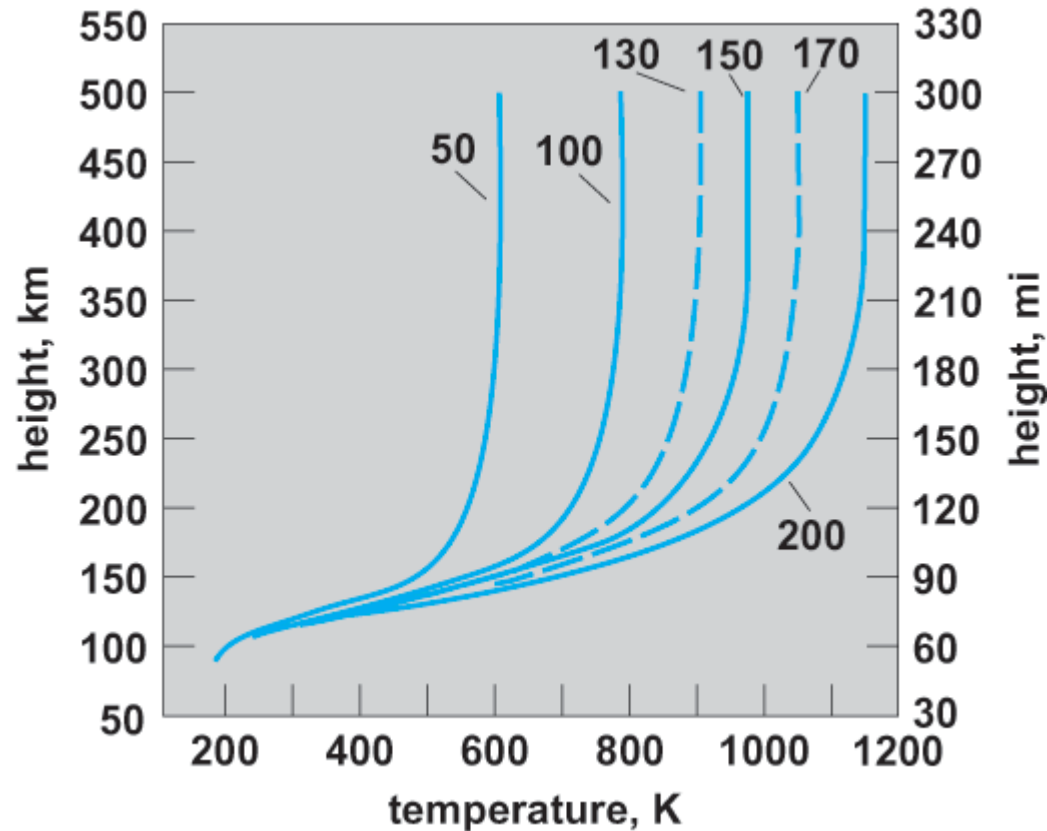

Figure: The thermospheric temperature varies with different values of the solar radio flux index  $F_{10.7}$  in units of  $10^{-22} \text{ Wm}^{-2}\text{Hz}^{-1}$  at 1 AU

# The neutral atmosphere

## Atmospheric gas in a stationary state

Above the surface of the Earth, the atmospheric pressure  $p$  and density  $n$  are given

$$p = p_0 \exp \left[ - \int_{z_0}^z \frac{mg}{k_B T(z)} dz \right] = p_0 \exp \left[ - \int_{z_0}^z \frac{dz}{H(z)} \right]$$

and

$$n = n_0 \frac{T_0}{T(z)} \exp \left[ - \int_{z_0}^z \frac{dz}{H(z)} \right]$$

Where  $p_0$  and  $n_0$  are values at a reference height  $z_0$ . If the atmosphere is isothermal ( $T=\text{constant}$ ), the **scale height**  $H$

$$H = \frac{k_B T}{mg}$$

Is independent of altitude and then the hydrostatic equations are

$$p = p_0 \exp \left( - \frac{z - z_0}{H} \right), \quad n = n_0 \exp \left( - \frac{z - z_0}{H} \right)$$

# The neutral atmosphere

## Atmospheric gas in a stationary state

Since the scale height is in fact dependent on temperature and we now know that temperature increases with altitude in the thermosphere,

$$H = \frac{k_B T}{mg}$$

we will see in upcoming lectures that it is possible to take ISR measurements with lower range resolution in the F-region as compared to the lower E-region.

# The neutral atmosphere

## Atmospheric regions by composition

- The **homosphere** is the region below about 100 km altitude, where all gas constituents are fully mixed; i.e. the relative concentrations of different molecular species are independent of height. This is caused by turbulent mixing of the air.
- The **turbopause** is the upper boundary of the homosphere at an altitude of about 100 km.
- The **heterosphere** is the region above the homosphere. In the absence of atmospheric turbulence, each molecular species distributes with height independently of the other species (according to its own scale height). At great altitudes light molecular species dominate.

# The neutral atmosphere

## Composition in the heterosphere

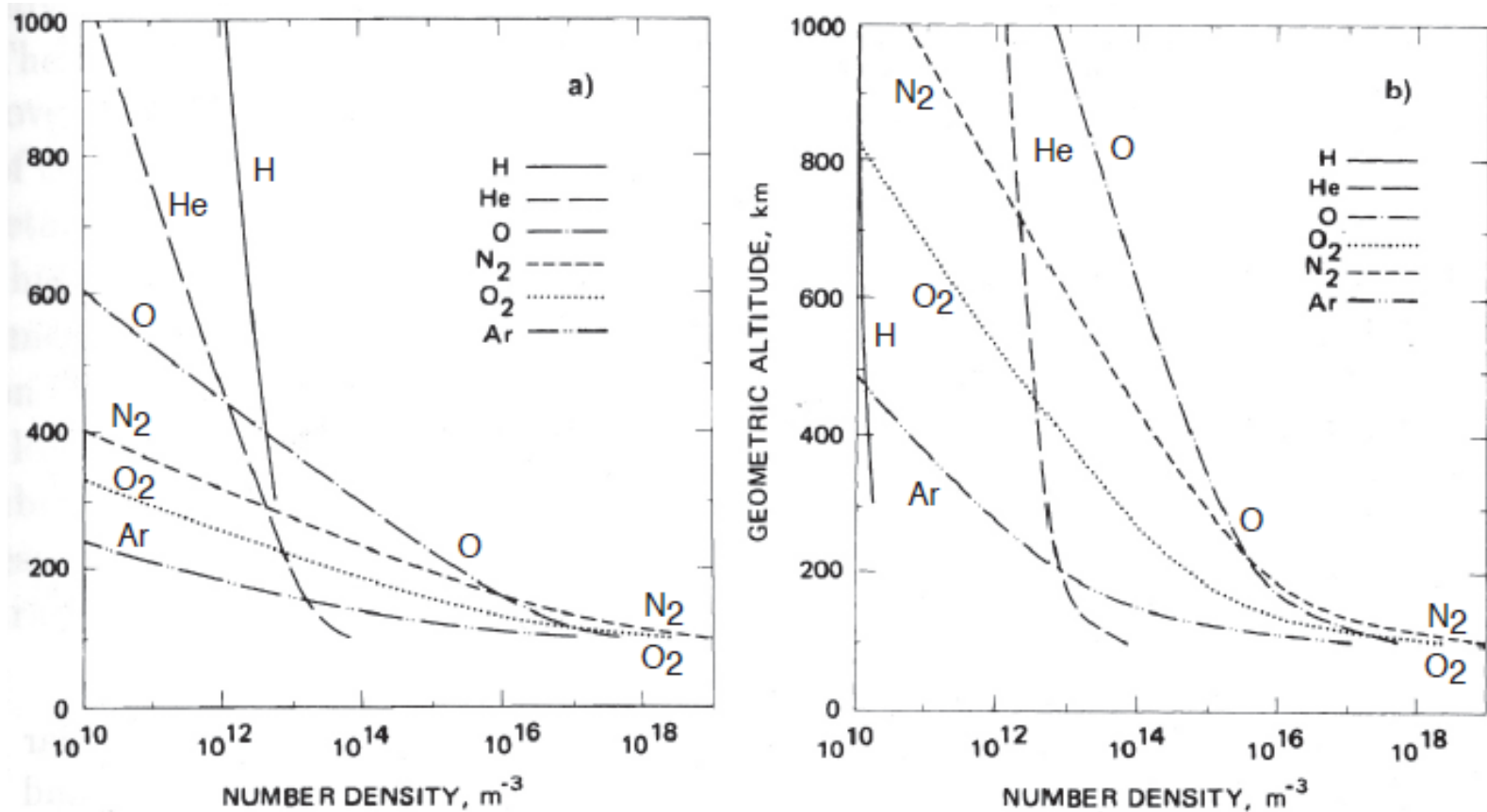

Figure: Atmospheric composition during (a) solar minimum and (b) solar maximum (U. S. Standard atmosphere, 1976).



# The ionosphere

Ionospheric regions and typical daytime electron densities:

- **D region:** 60-90 km,  $n_e = 10^8$ - $10^9$   $m^{-3}$
- **E region:** 90-150 km,  $n_e = 10^{10}$ - $10^{11}$   $m^{-3}$
- **F region:** 150-1000 km,  $n_e = 10^{11}$ - $10^{12}$   $m^{-3}$

The ionosphere has great variability:

- Solar cycle variations (in the upper F region)
- Day-night variations in lower F, E, and D regions
- Space weather effects based on short-term solar variability (lower F, E, and D regions)

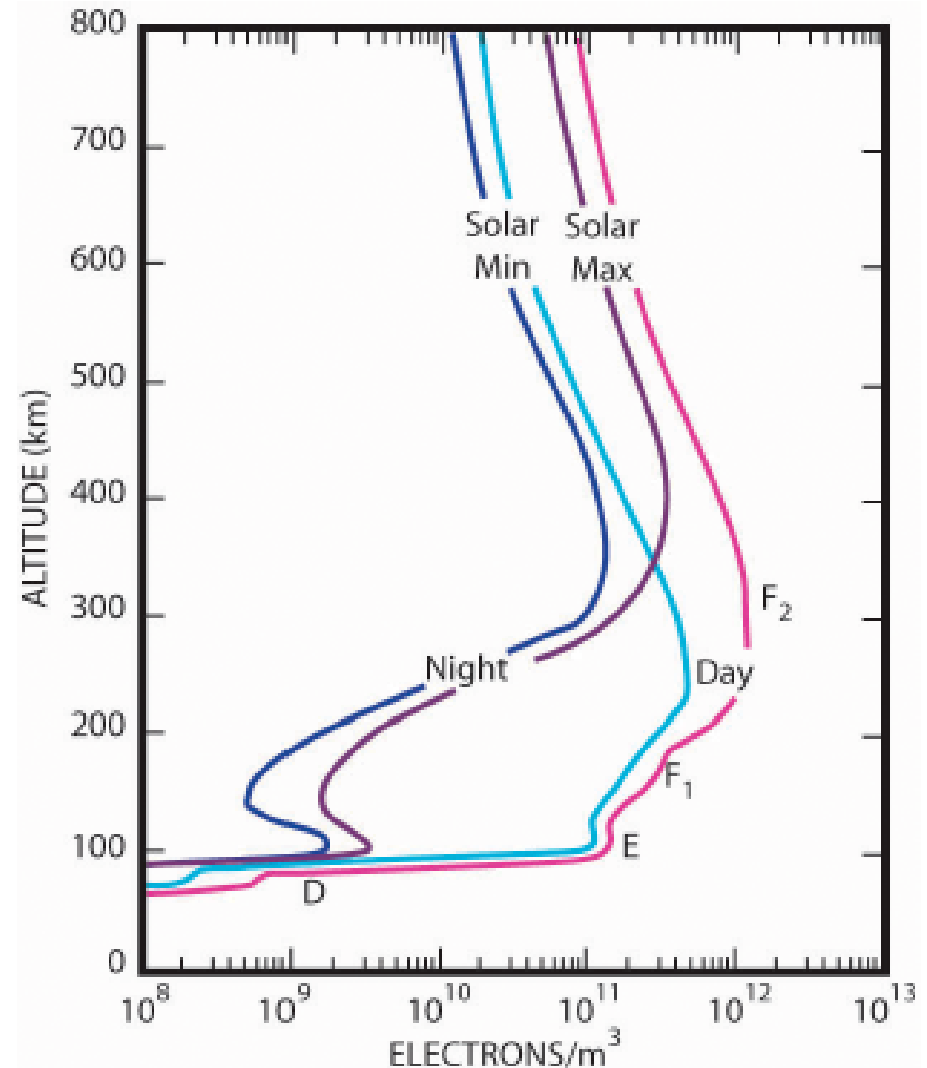

# The ionosphere

**Question:** In the solar wind plasma, and in many parts of the magnetosphere there is 100% ionization. What percentage of the atmosphere is ionized?

# The ionosphere

**Answer:** At maximum, only 1% of the neutral atmosphere is ionized.

# The ionosphere

## Composition in the heterosphere

- $O^+$  dominates around the F region peak and  $H^+$  starts to increase rapidly above 300 km.
- $NO^+$  and  $O_2^+$  are the dominant ions in E and upper D regions (Ion chemistry: e.g.  $N_2^+ + O \rightarrow NO^+ + N$ ).
- The D-region (not shown) contains positive and negative ions (e.g.  $O_2^-$ ) and ion clusters (e.g.  $H^+(H_2O)_n$ ,  $(NO)^+(H_2O)_n$ )

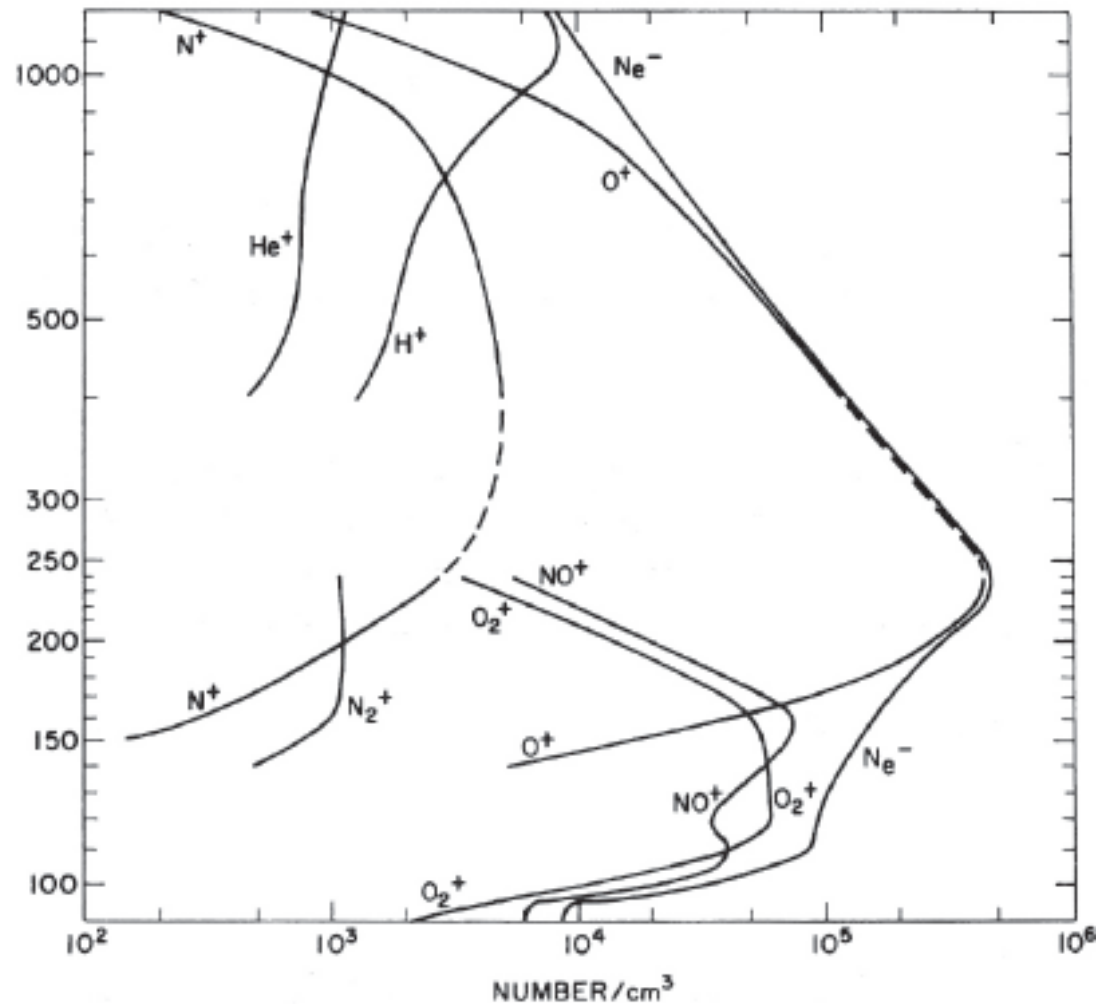

# The ionosphere

## Ion temperatures

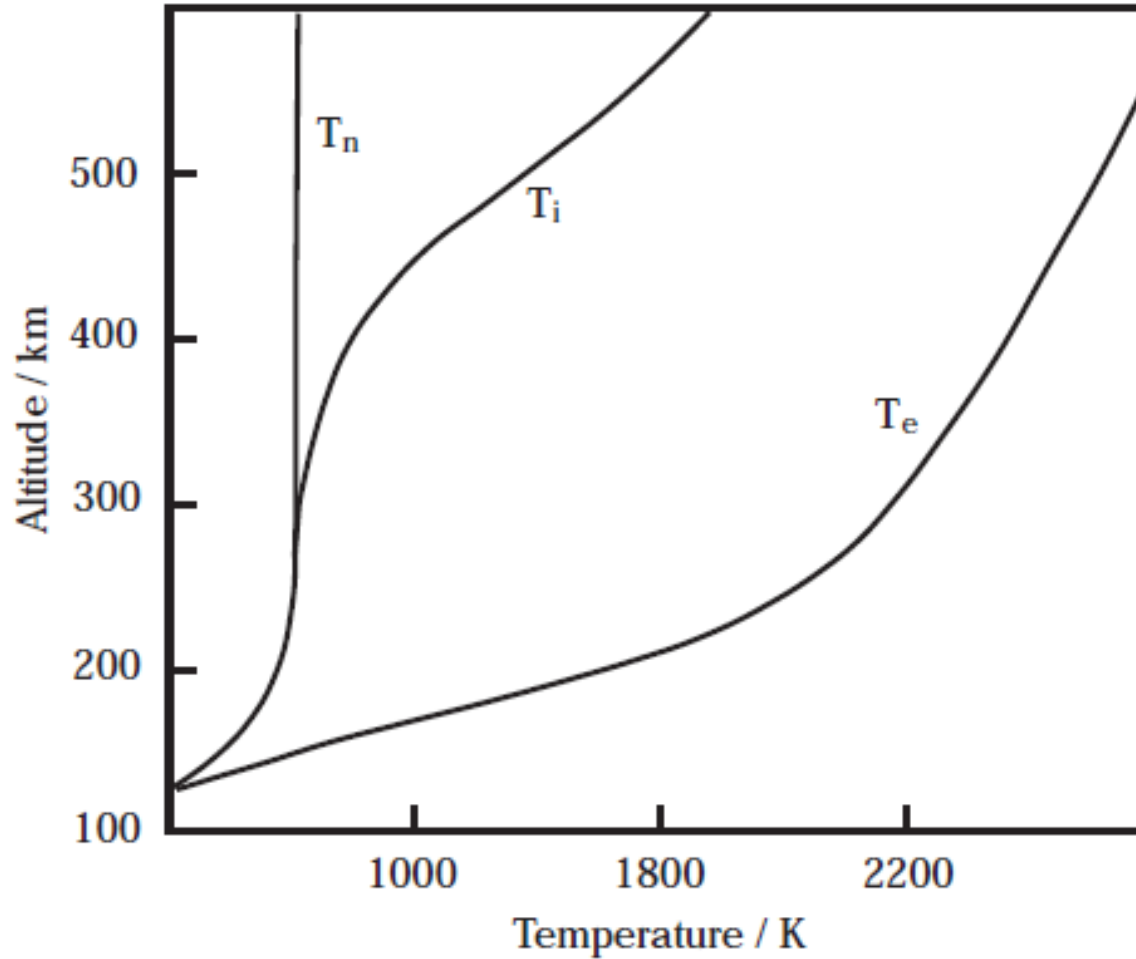

Figure: An example of neutral, ion, and electron temperature profiles

# The ionosphere

## ISR example

20011107 : 023158.1 - 023659.3

Fit Processed : 20011109

AZ=141.0,EL=80.1 ==> AZ=141.0,EL=80.0

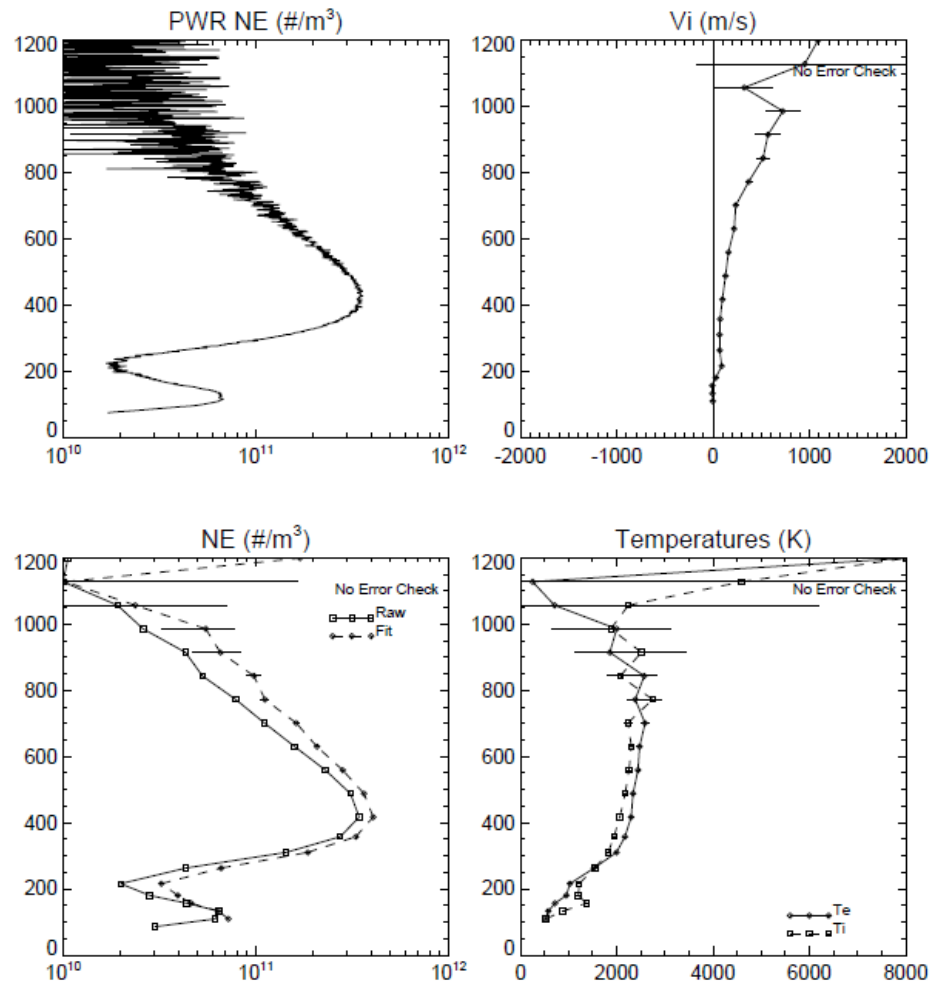

# The ionosphere

## ISR example

20011107 : 023158.1 - 023659.3  
 Fit Processed : 20011109  
 AZ=141.0,EL=80.1 ==> AZ=141.0,EL=80.0

Note: Sondrestrom data  
 Error bars increase with altitude  
 Pulse code affects range resolution and altitudes

Electron density from raw power –  
 Highly oversampled

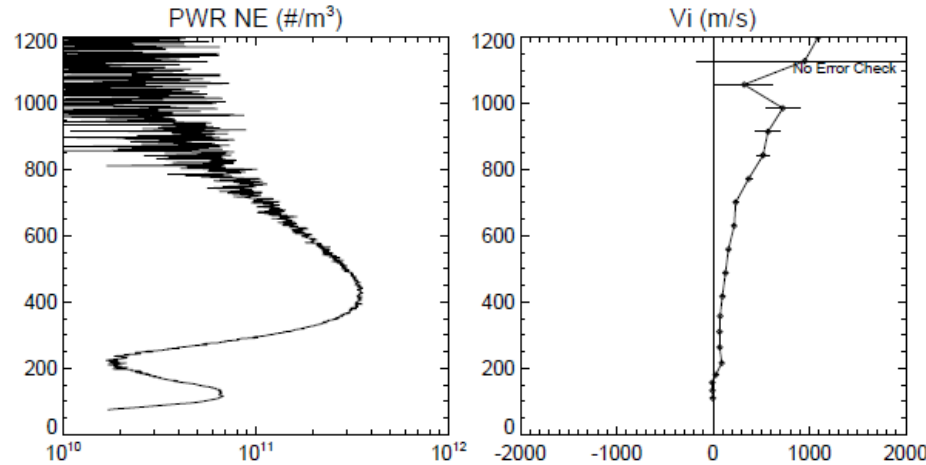

Ion velocity

Corrected “fitted”  
 electron density

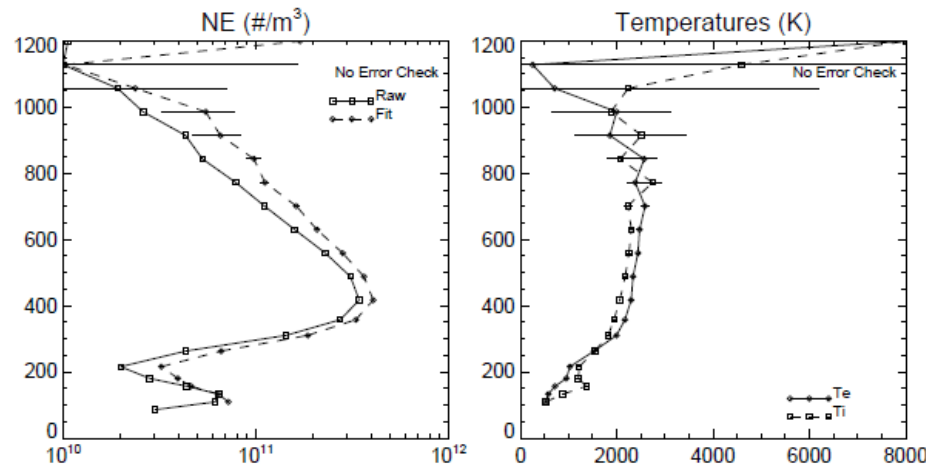

Ion and Electron  
 temperatures

# The ionosphere

## Dynamics of the ionosphere

The important equations for ions (number density  $n_i$ ) and electrons (number density  $n_e$ ) in the ionosphere are the continuity equations:

$$\frac{\partial n_{i,e}}{\partial t} + \nabla \cdot (n_{i,e} \mathbf{v}_{i,e}) = q_{i,e} - l_{i,e},$$

where  $q$  is the production rate per unit volume and  $l$  is the loss rate per unit volume; and the momentum equations:

$$n_i m_i \left( \frac{\partial}{\partial t} + \mathbf{v}_i \cdot \nabla \right) \mathbf{v}_i = n_i m_i \mathbf{g} + e n_i (\mathbf{E} + \mathbf{v}_i \times \mathbf{B}) - \nabla p_i - n_i m_i \nu_i (\mathbf{v}_i - \mathbf{u})$$
$$n_e m_e \left( \frac{\partial}{\partial t} + \mathbf{v}_e \cdot \nabla \right) \mathbf{v}_e = n_e m_e \mathbf{g} - e n_e (\mathbf{E} + \mathbf{v}_e \times \mathbf{B}) - \nabla p_e - n_e m_e \nu_e (\mathbf{v}_e - \mathbf{u})$$

Where  $\mathbf{E}$  is the electric field,  $\mathbf{B}$  is magnetic induction,  $p_i$  and  $p_e$  are the pressures of the ion and electron gas, and the ion-neutral and electron-neutral collision frequencies are denoted by  $\nu_i$  and  $\nu_e$  respectively



# The ionosphere

## Ionization source: solar radiation

Chapman production function by using a height variable  $h' = h - \ln \sec \chi$ :

$$q(\chi, h') = q_{m,0} \cos \chi \cdot \exp \left[ 1 - h' - e^{-h'} \right],$$

where  $\chi$  is the solar zenith angle and  $h = (z - z_{m,0})/H$ , where  $H$  is the atmospheric scale height.

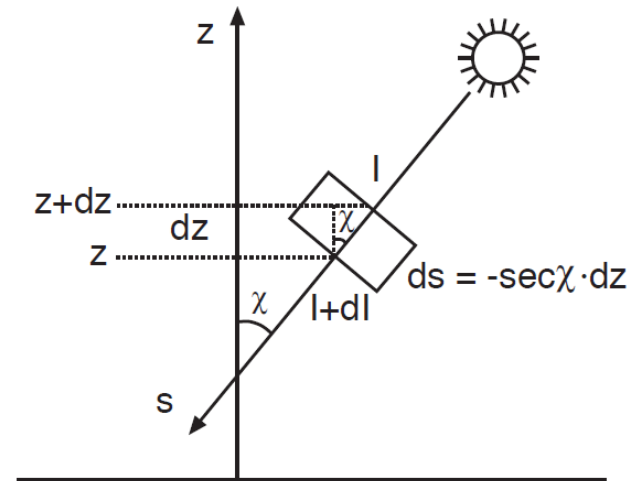
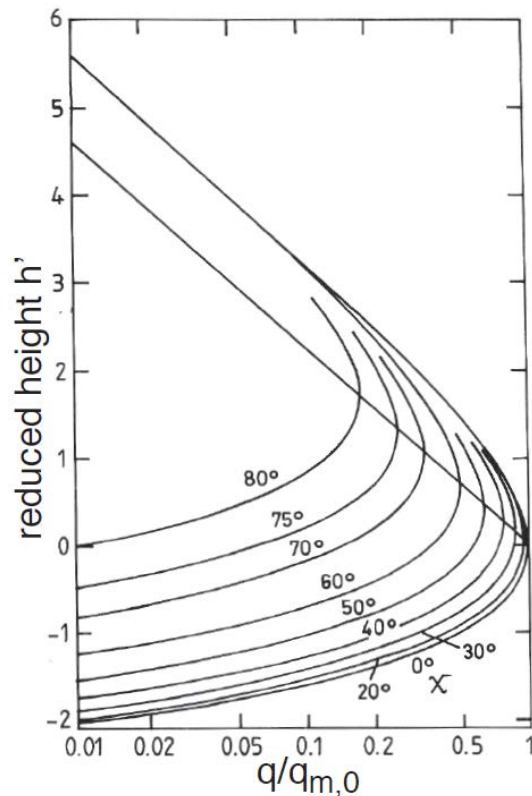

With larger zenith angle  $\chi$ , the peak of ionization rate rises in altitude and decreases by a factor  $\cos \chi$ .

# The ionosphere

Ionization source: particle precipitation (electrons)

High-energy electron deposit energy at lower altitudes.

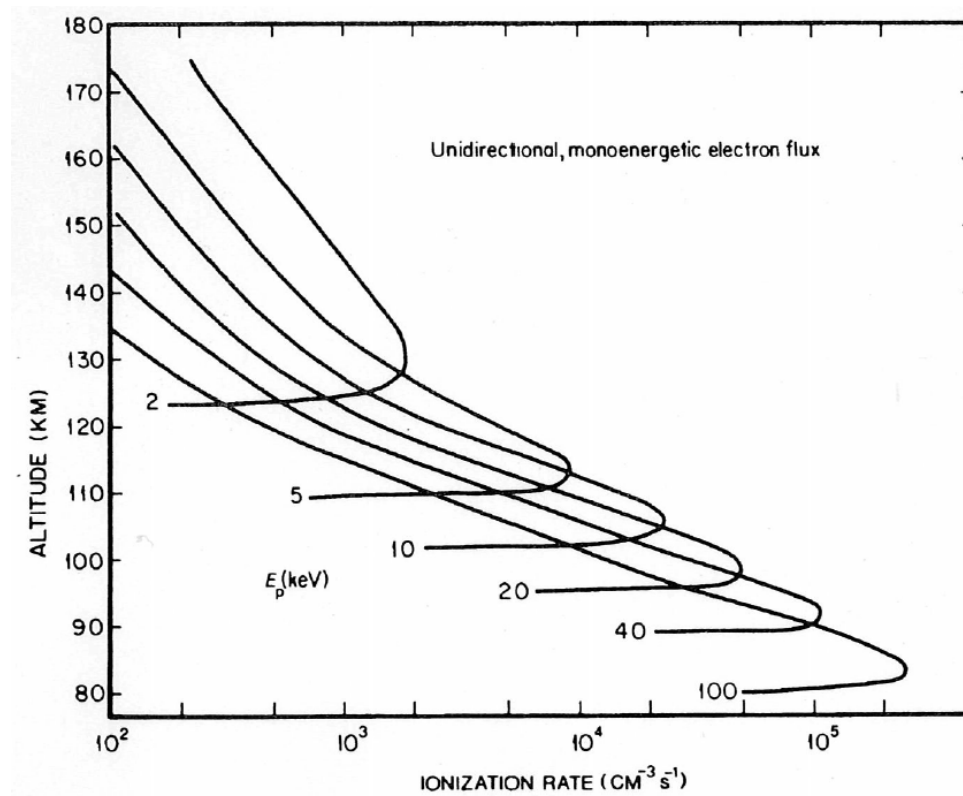

Figure: Ionization rate for monoenergetic electrons with energies 2-100 keV

# The ionosphere

Ionization source: particle precipitation (protons)

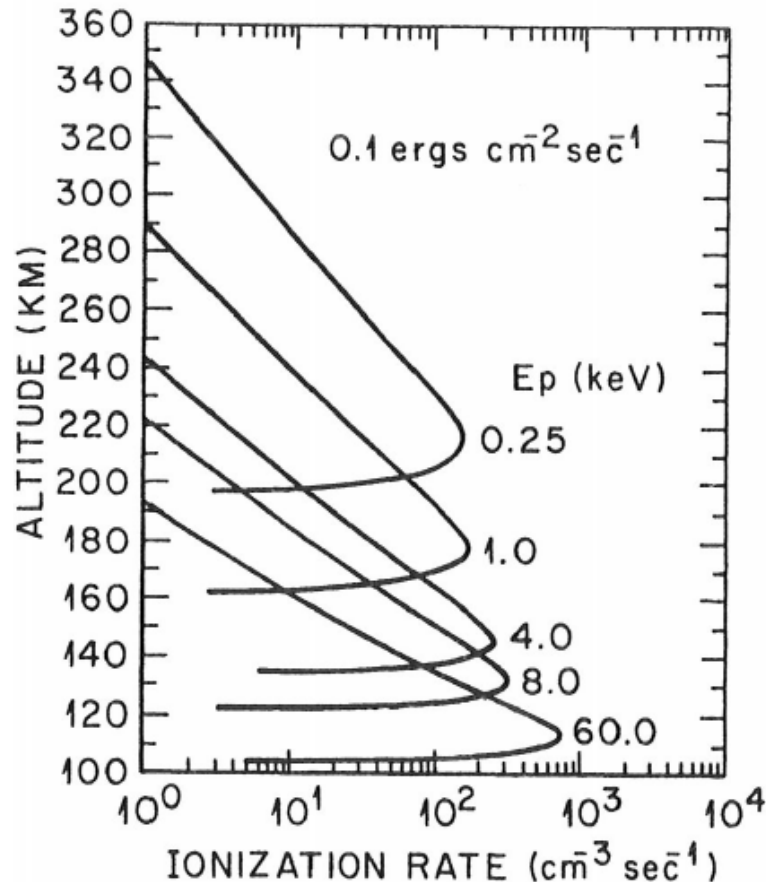

Figure: Ionization rate for monoenergetic protons with energies 0.25-60 keV

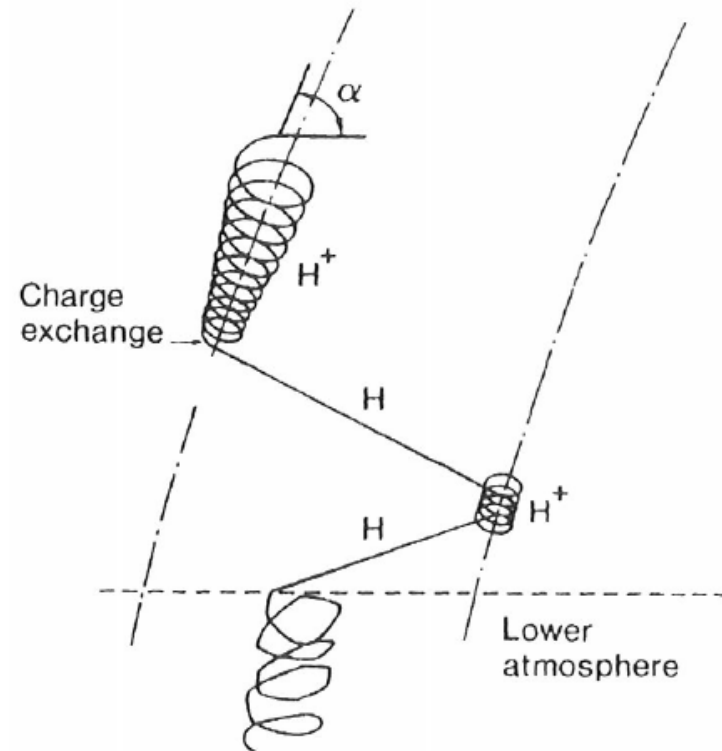
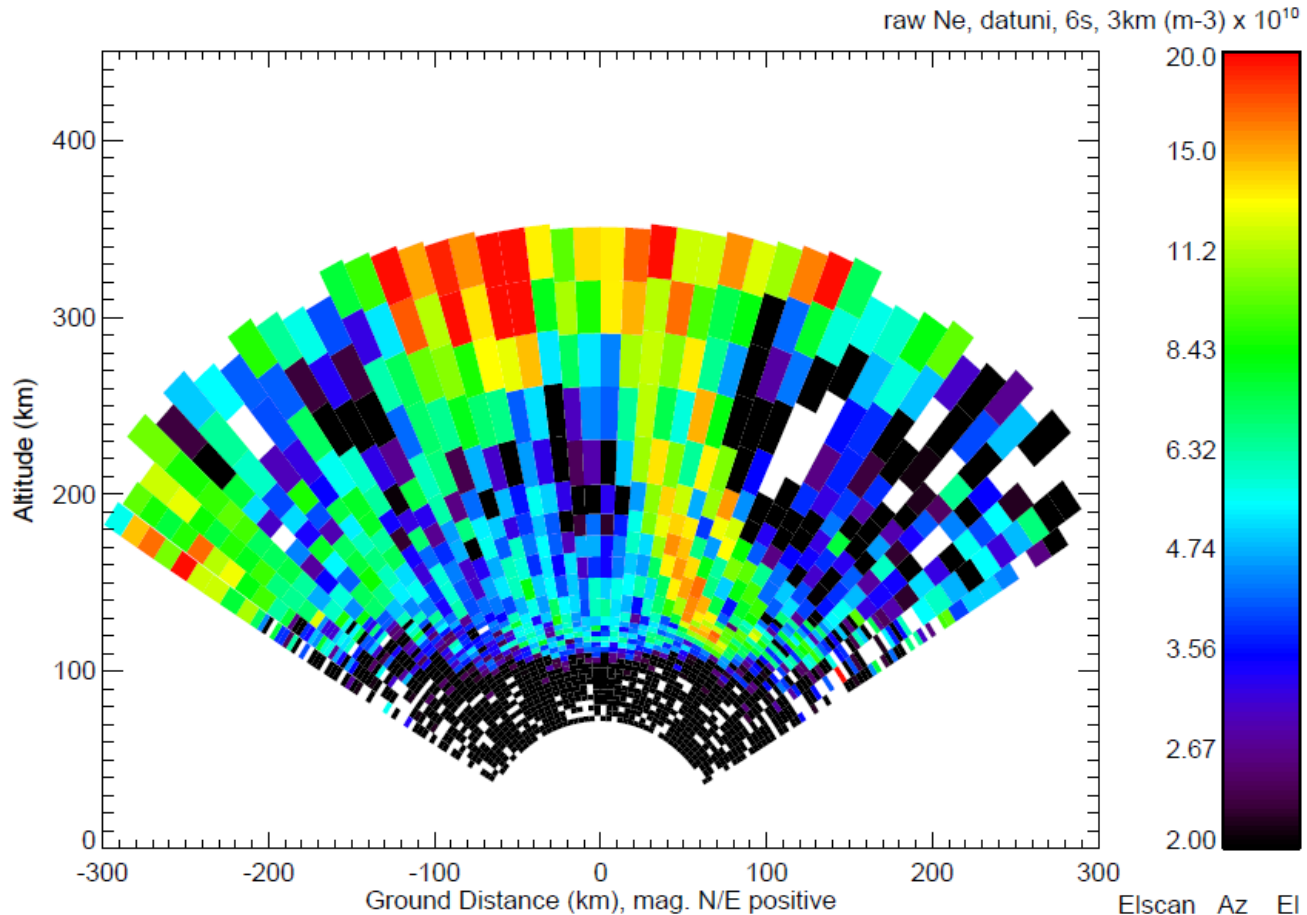

Figure: Protons may make charge exchange with neutral hydrogen.

# The ionosphere

## ISR example

2002 Mar 11 060621.9 - 060852.6 UT



acport-28424-28440-6s-3km.bs5

020311-0606-rawne.ps

# The ionosphere

## ISR example

2002 Mar 11 060621.9 - 060852.6 UT

Auroral E-region density enhancement extending into the F-region

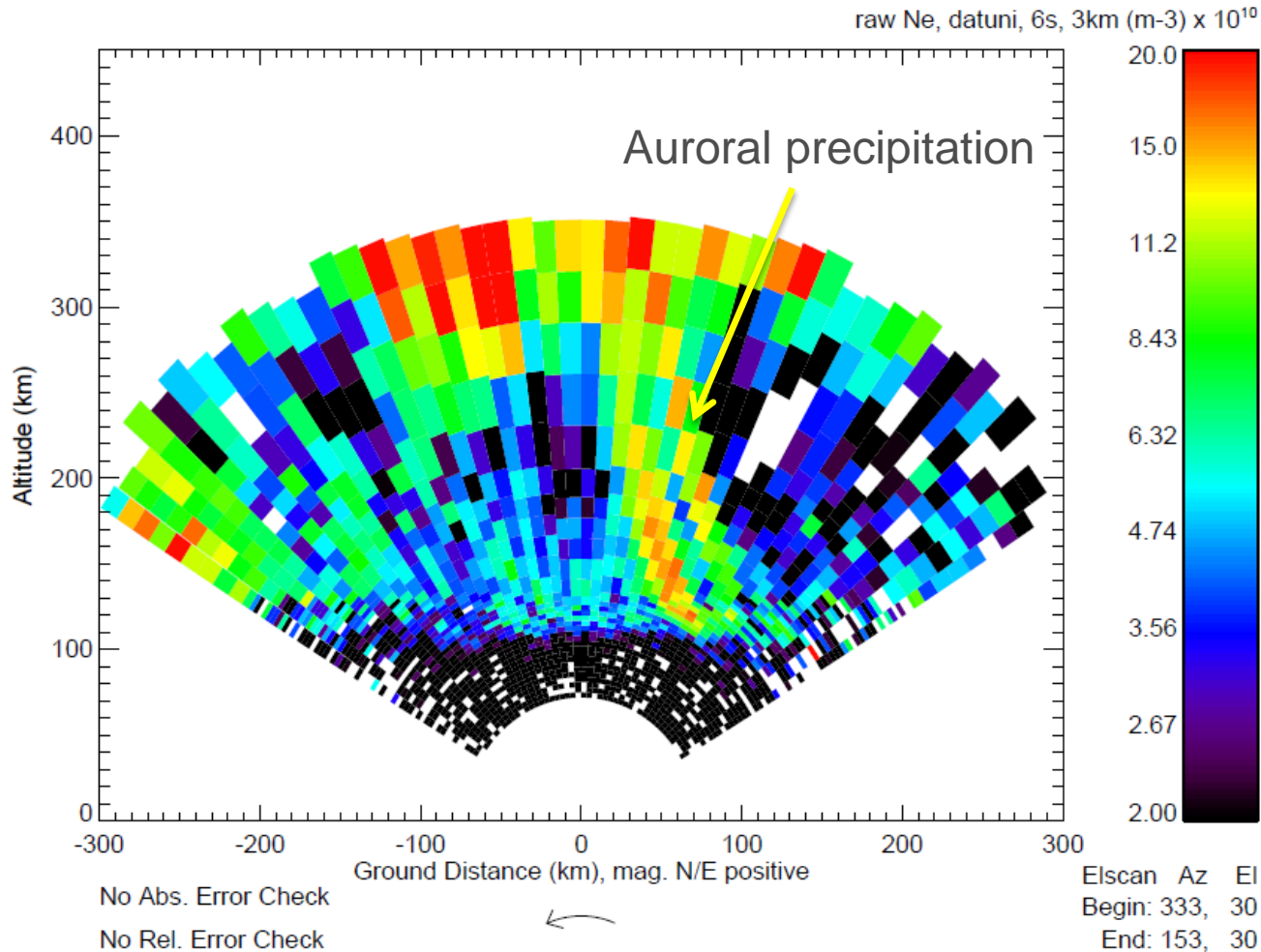

acport-28424-28440-6s-3km.bs5

020311-0606-rawne.ps

# The ionosphere

## ISR example

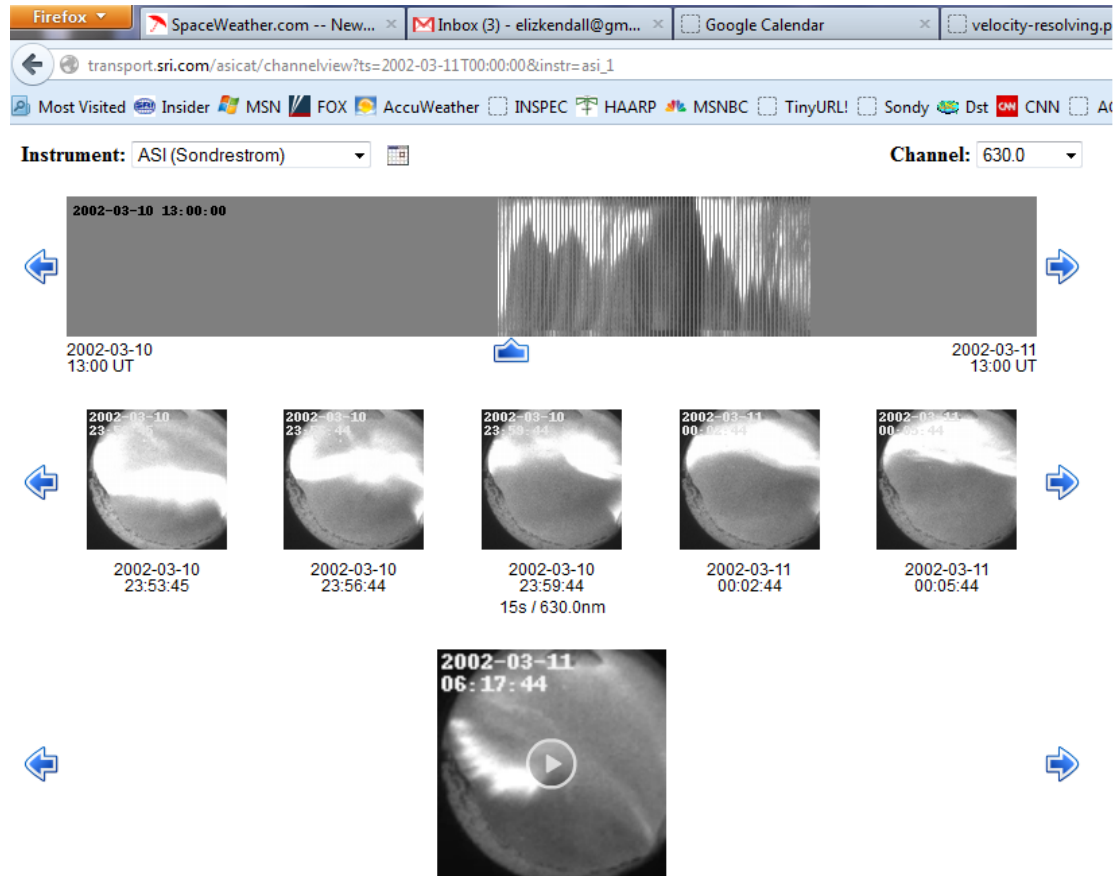

Not for publication.

© [SRI](#)

# The ionosphere

## Loss mechanisms

We have now dealt with the production rate, but there are also loss terms to deal with:

$$\frac{\partial n_{i,e}}{\partial t} + \nabla \cdot (n_{i,e} \mathbf{v}_{i,e}) = q_{i,e} - l_{i,e},$$

1. Recombination
2. Transport/Diffusion

While chemical recombination is very important at lower altitudes (D, E, F1 regions), diffusion plays a larger role at higher altitudes (F2 region) where the densities are very low.

# The ionosphere

## Equations of motion

Conductivities matter because the ionosphere is a plasma with an embedded magnetic field.

$$\nabla \cdot [\sigma \cdot (\mathbf{E}(\mathbf{r}, t) + \mathbf{U}(\mathbf{r}, t) \times \mathbf{B})] = 0$$

Parallel equation of motion:

$$q\mathbf{E} = m_i \nu_{in} \mathbf{u}_i \quad -e\mathbf{E} = m_e \nu_{en} \mathbf{u}_e$$

Perpendicular equation of motion:

$$q(\mathbf{E}_\perp + \mathbf{u}_i \times \mathbf{B}) = m_i \nu_{in} \mathbf{u}_{\perp i}$$
$$-e(\mathbf{E}_\perp + \mathbf{u}_e \times \mathbf{B}) = m_e \nu_{en} \mathbf{u}_{\perp e}$$



# The ionosphere

## Collision frequencies

Ion and electrons collide with neutrals as they gyrate. How they move in response to imposed force fields depends very much on the collision frequency relative to the gyro-frequency.

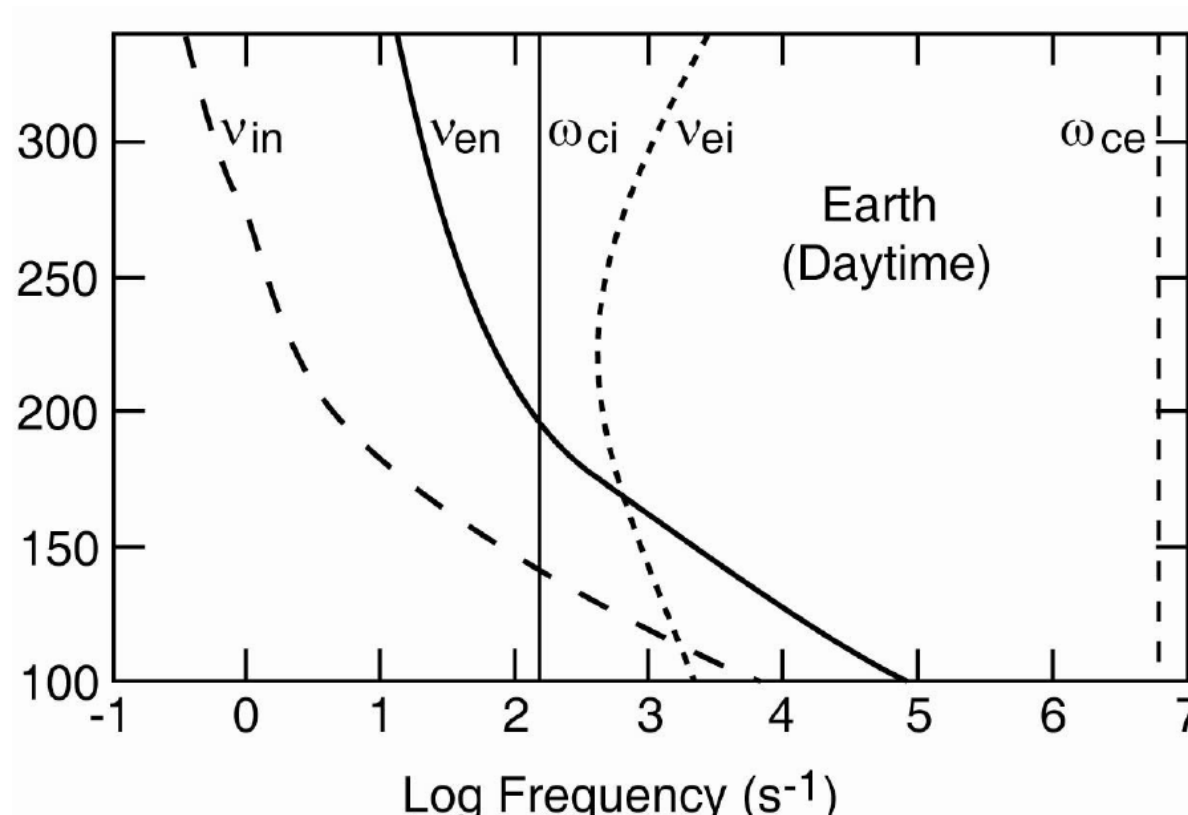

# The ionosphere

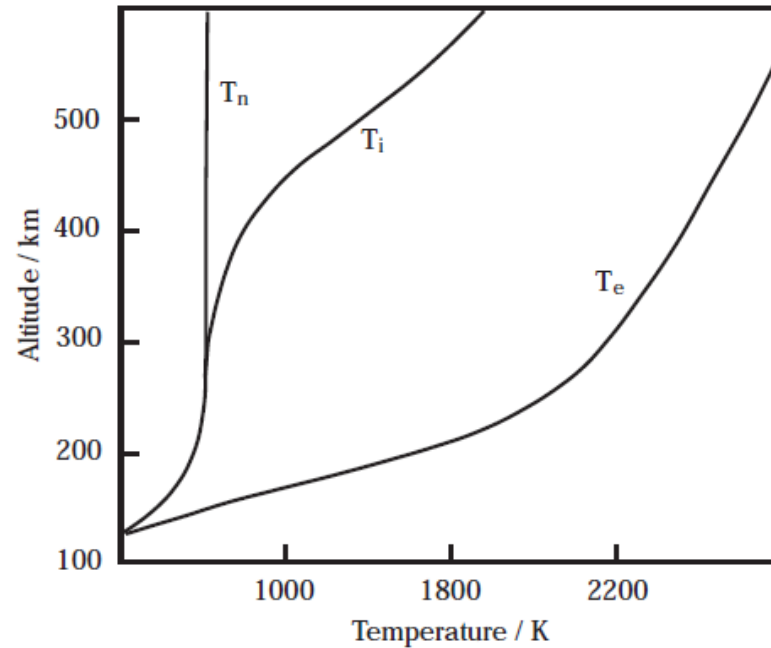

**Question:** Why are  $T_n$  and  $T_i$  identical at low altitudes? Why is  $T_e$  so much higher than either  $T_n$  or  $T_i$ ?

# The ionosphere

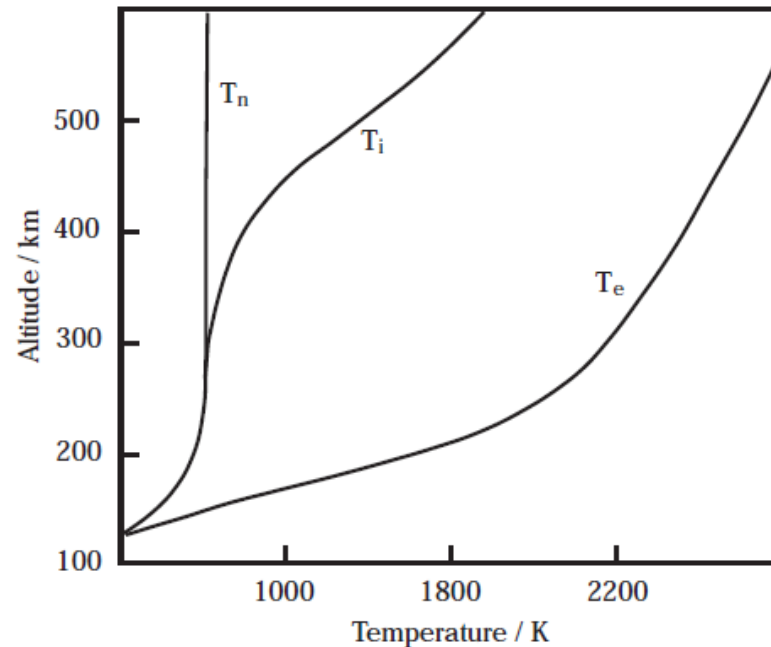

**Answer:** At lower altitudes, the ions and neutrals have the same temperature due to a high rate of collisions and the high mass of the ions. The electrons have a gyrofrequency much higher than the collision frequency. The electron temperature typically remains higher than the ion temperature due to its much lower mass.

# The ionosphere

## Conductivity

- Pedersen conductivity (parallel to E)

$$\sigma_1 = \left[ \frac{1}{m_e \nu_{en}} \left( \frac{\nu_{en}^2}{\nu_{en}^2 + \Omega_e^2} \right) + \frac{1}{m_i \nu_{in}} \left( \frac{\nu_{in}^2}{\nu_{in}^2 + \Omega_i^2} \right) \right] n_e e^2$$

- Hall conductivity (along EXB)

$$\sigma_2 = \left[ \frac{1}{m_e \nu_{en}} \left( \frac{\Omega_e \nu_{en}}{\nu_{en}^2 + \Omega_e^2} \right) - \frac{1}{m_i \nu_{in}} \left( \frac{\Omega_i \nu_{in}}{\nu_{in}^2 + \Omega_i^2} \right) \right] n_e e^2$$

- Parallel conductivity (parallel to B)

$$\sigma_0 = \left[ \frac{1}{m_e \nu_{en}} + \frac{1}{m_i \nu_{in}} \right] n_e e^2$$

- Conductivity tensor

$$j = \begin{pmatrix} \sigma_1 & \sigma_2 & 0 \\ -\sigma_2 & \sigma_1 & 0 \\ 0 & 0 & \sigma_0 \end{pmatrix} \begin{pmatrix} E_x \\ E_y \\ E_z \end{pmatrix}$$

# The ionosphere

## Collision frequencies

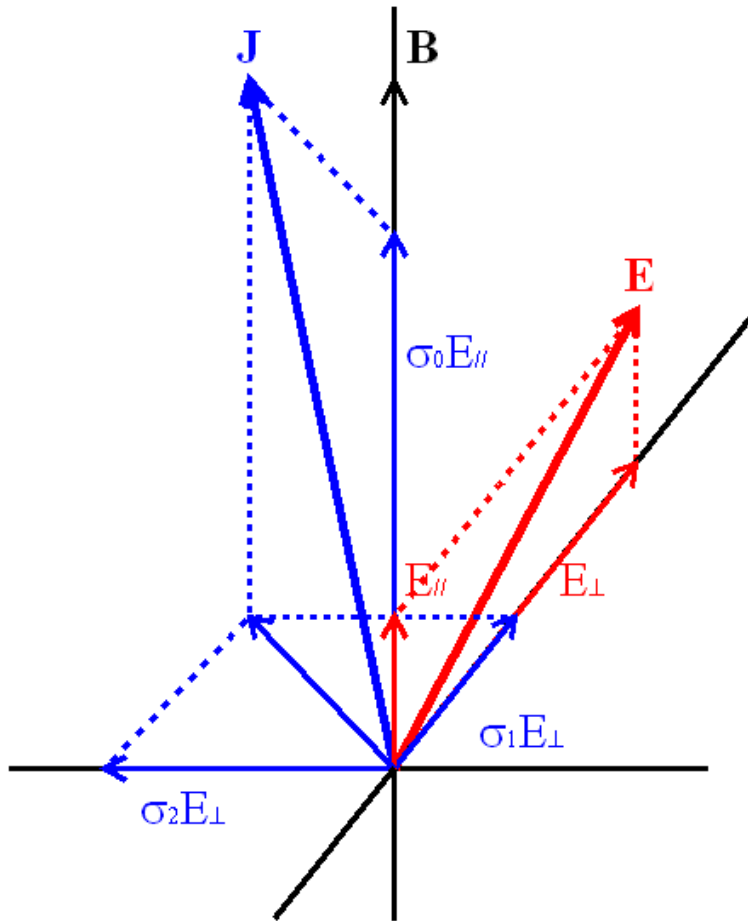

$\mathbf{B}$ : Geomagnetic field vector

$\mathbf{E}$ : Electric field vector

$\mathbf{E}_{\perp}$ : Perpendicular component of the electric field

$\mathbf{E}_{\parallel}$ : Parallel component of the electric field

$\mathbf{J}$ : Electric current vector

$\sigma_0 \mathbf{E}_{\parallel}$ : Parallel current

$\sigma_1 \mathbf{E}_{\perp}$ : Pedersen current

$\sigma_2 \mathbf{E}_{\perp}$ : Hall current

# The ionosphere

## Conductivities

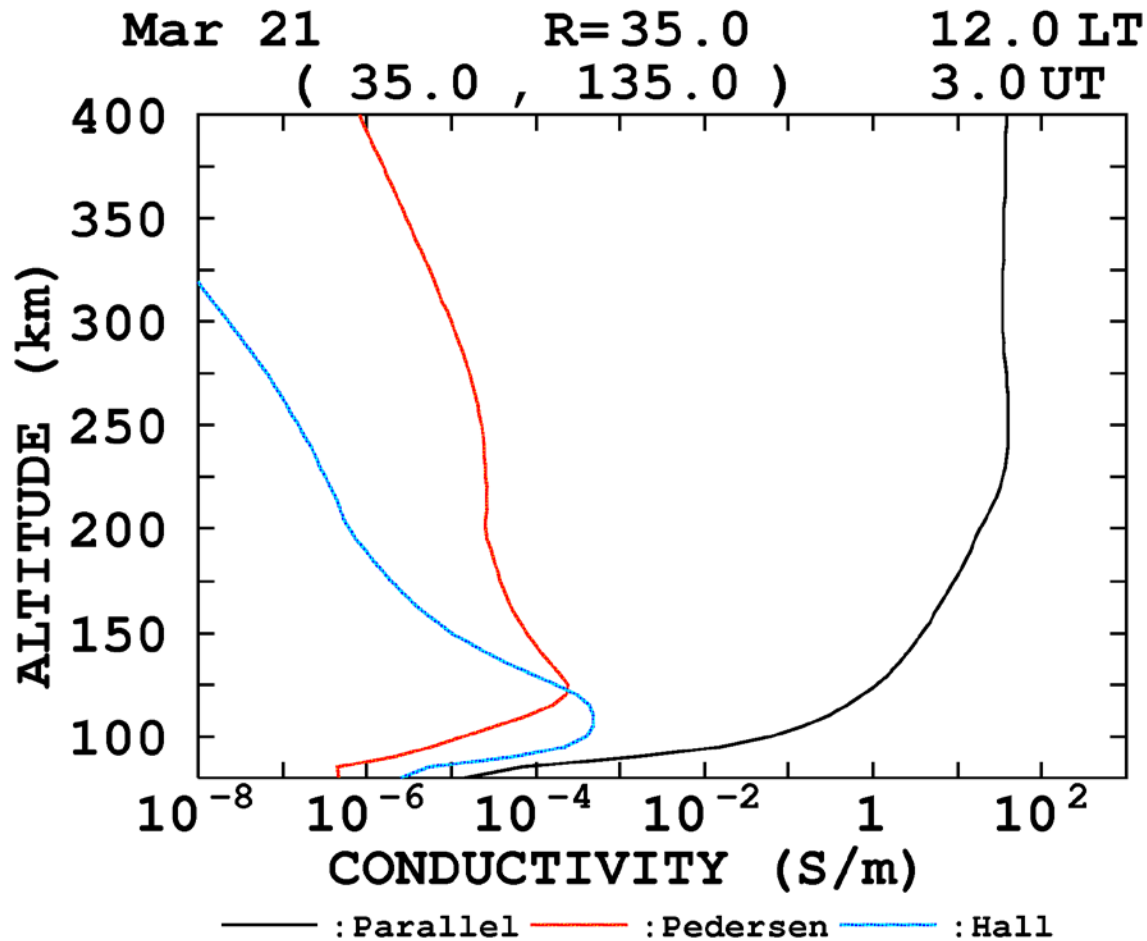

# The ionosphere

## Conductivities

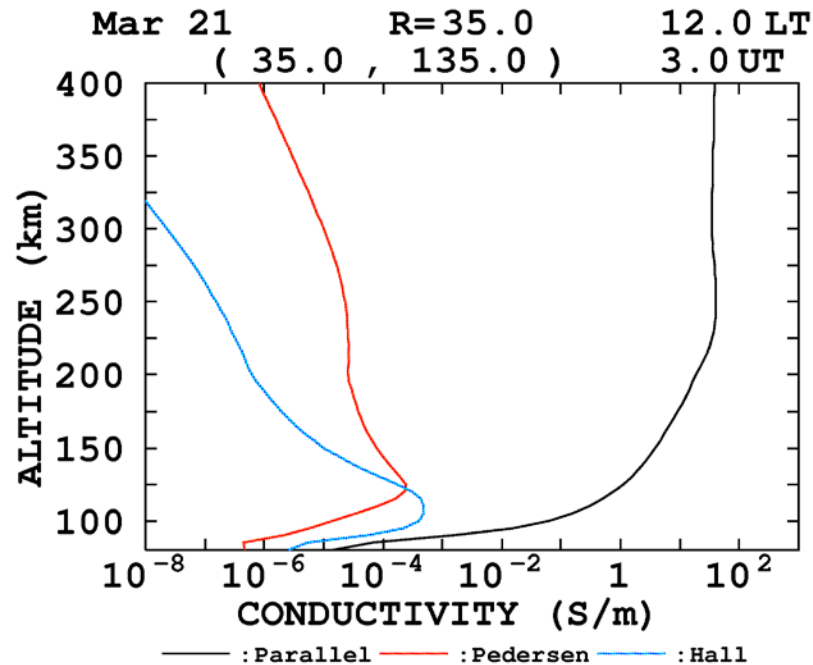

**Question:** There is a peak in the Hall and Pedersen conductivities in the E-region. What ionospheric phenomenon also peaks at this altitude?

# The ionosphere

## Conductivities

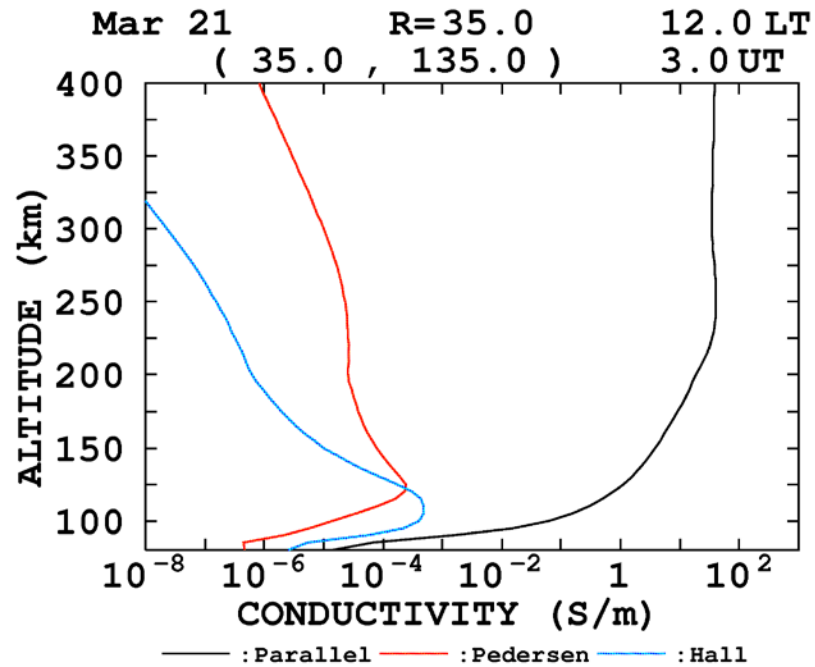

**Answer:** The auroral and equatorial electrojets



# The ionosphere

## Refraction

Radio waves refract in the atmosphere similar to light.

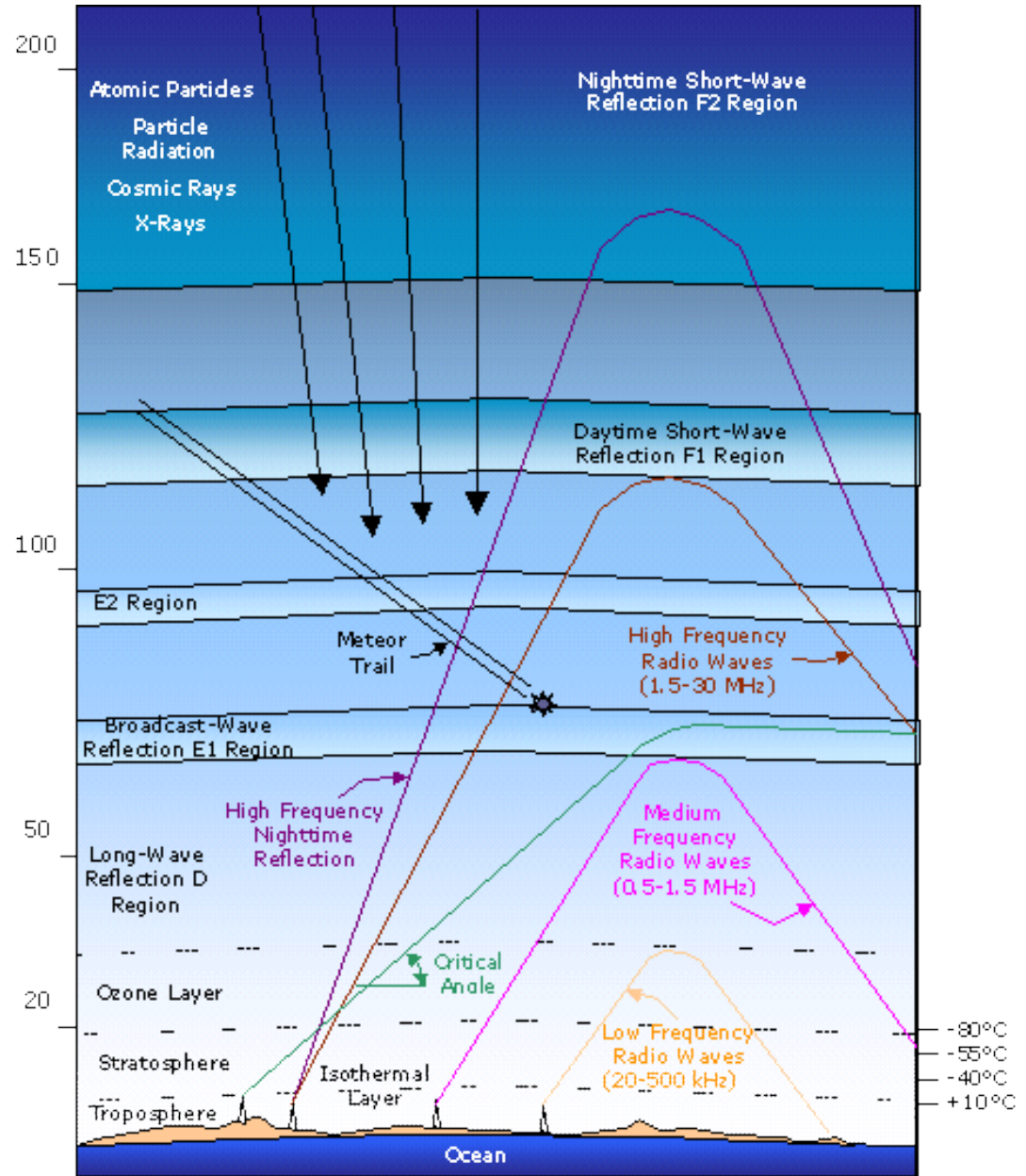

# The ionosphere

## Refraction

**Question:** What happens to waves above the frequencies described in the figure to the right?

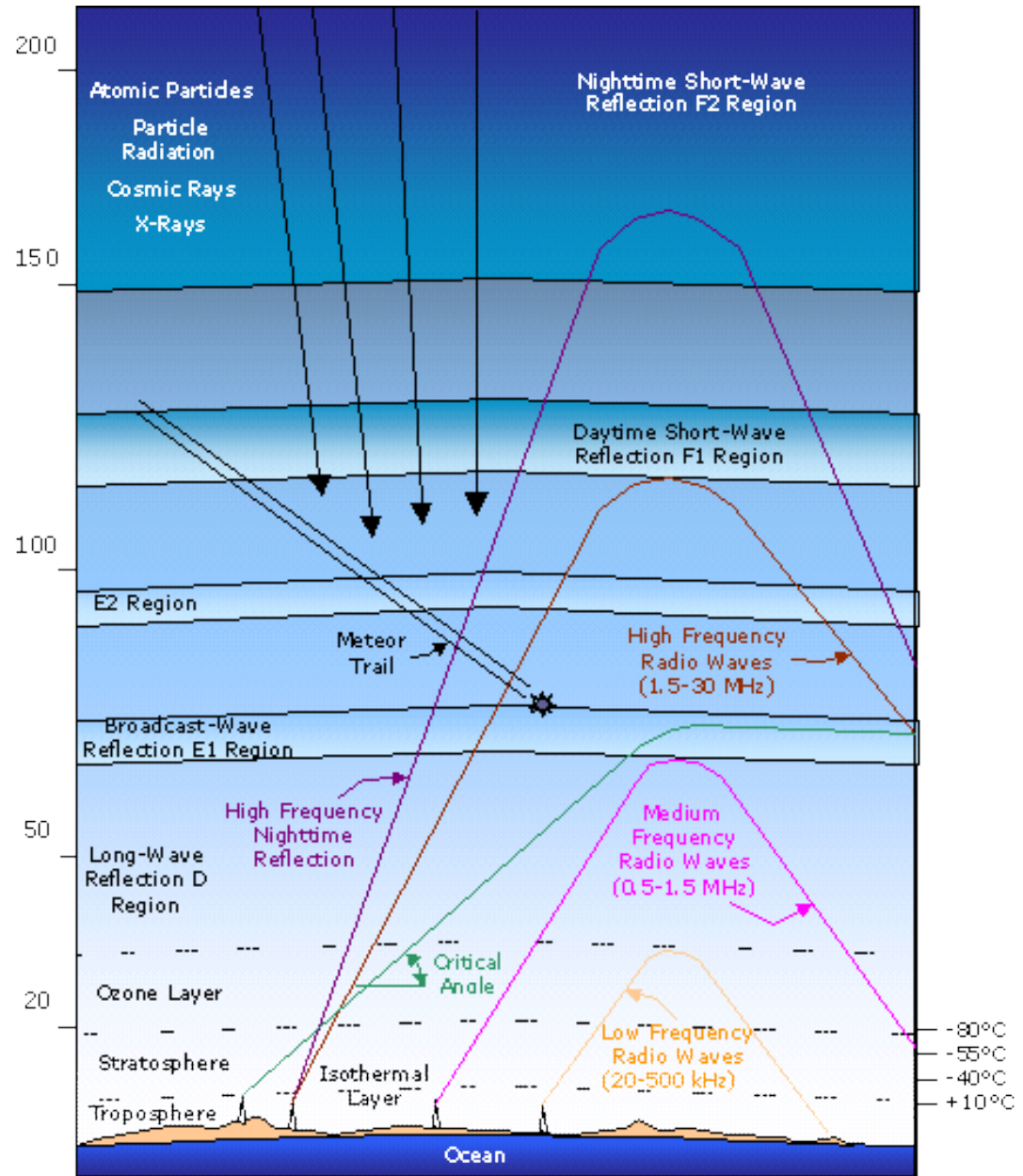

# The ionosphere

## Refraction

**Answer:** Waves above ~30 MHz pass through the ionosphere with little interaction (vertical incidence). With regards to ISRs, this allows us to assume the radar wave is unchanged through the scattering volume and also that the incident wave doesn't affect the scattered wave. This will be discussed in more detail in upcoming lectures.

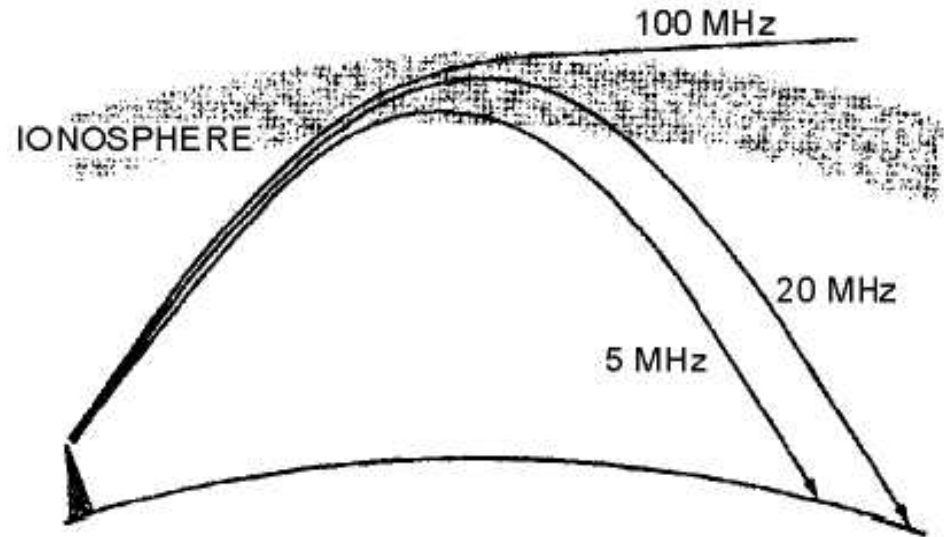

# The ionosphere

## Index of refraction

$$n^2 = \underline{1} - \frac{X(1-X)}{(1-X) - \frac{1}{2}Y_T^2 \pm \left( \frac{1}{4}Y_T^4 + (1-X)^2 Y_L^2 \right)^{1/2}}$$

$$\underline{X} = \frac{\omega_N^2}{\omega^2} \quad Y = \frac{\omega_H}{\omega} \quad \omega_N = \left( \frac{Ne^2}{\varepsilon_0 m_e} \right)^{1/2} \quad \omega_H = \frac{e|B|}{m_e}$$

$\omega$  = the angular frequency of the radar wave,

$Y_L = Y \cos \theta$ ,  $Y_T = Y \sin \theta$ ,

$\theta$  = angle between the wave vector  $\bar{k}$  and  $\bar{B}$ ,

$\bar{k}$  = wave vector of propagating radiation,

$\bar{B}$  = geomagnetic field,  $N$  = electron density

$e$  = electronic charge,  $m_e$  = electron mass,

and  $\varepsilon_0$  = permittivity constant.

# The ionosphere

## Debye length

- The Debye length is a measure of the plasma's ability to shield out electric potentials that are applied to it
- The Debye length marks the division between different regimes of plasma's behavior; i.e. collective plasma motion versus that of individual particle motion.
- Plasma phenomenon that take place over distances greater than the Debye length must be described in terms of collective behavior of the plasma.
- Plasma will not support large potential variations (i.e. will seek to maintain charge neutrality) over distances larger than the Debye length.
- Potential gradients that do exist have a characteristic length parameter equal to a Debye length.
- Their potential gradients are characterized by a natural oscillation frequency known as the plasma frequency.

# The ionosphere

## Debye length

- The Debye length increases with altitude – from a few millimeters in the F-region up to meters in the magnetosphere
- The Debye length in the E and F regions ranges from 0.1 – 1 cm

$$\lambda_D \simeq 69 \sqrt{T_e / n_e}$$

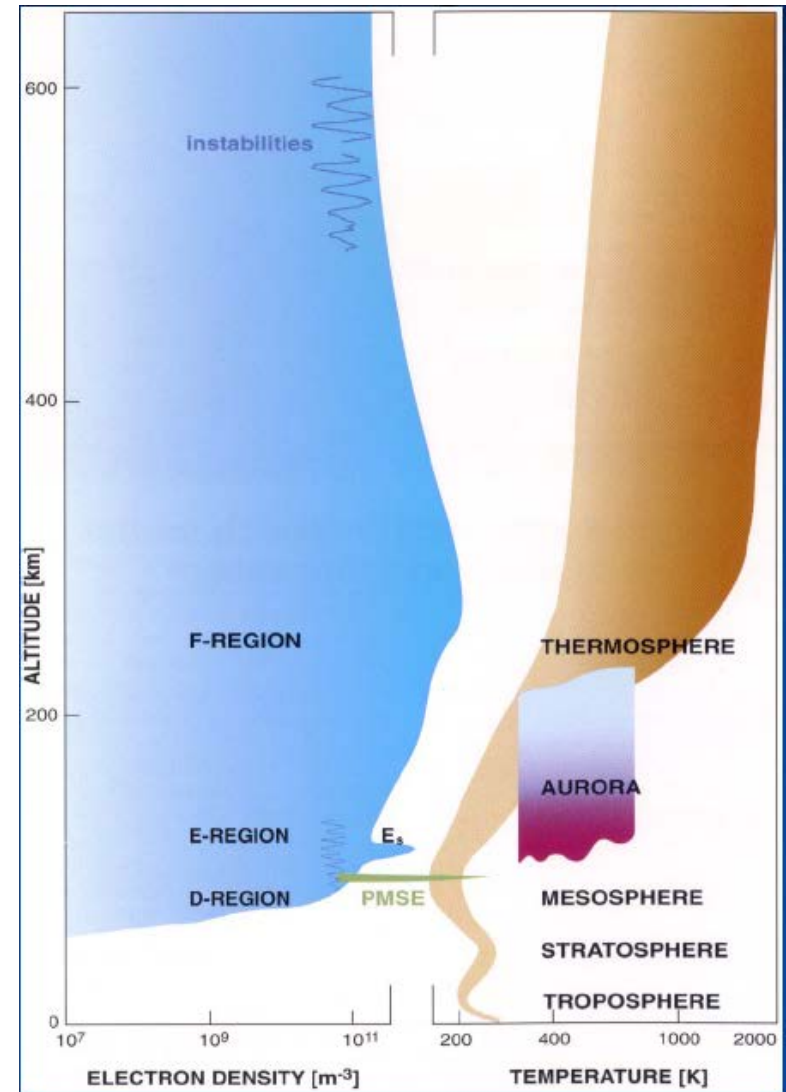

# The ionosphere

**Question:** If we want to measure bulk plasma parameters with an incoherent scatter radar, how will the Debye length affect our choice of radar frequency?

# The ionosphere

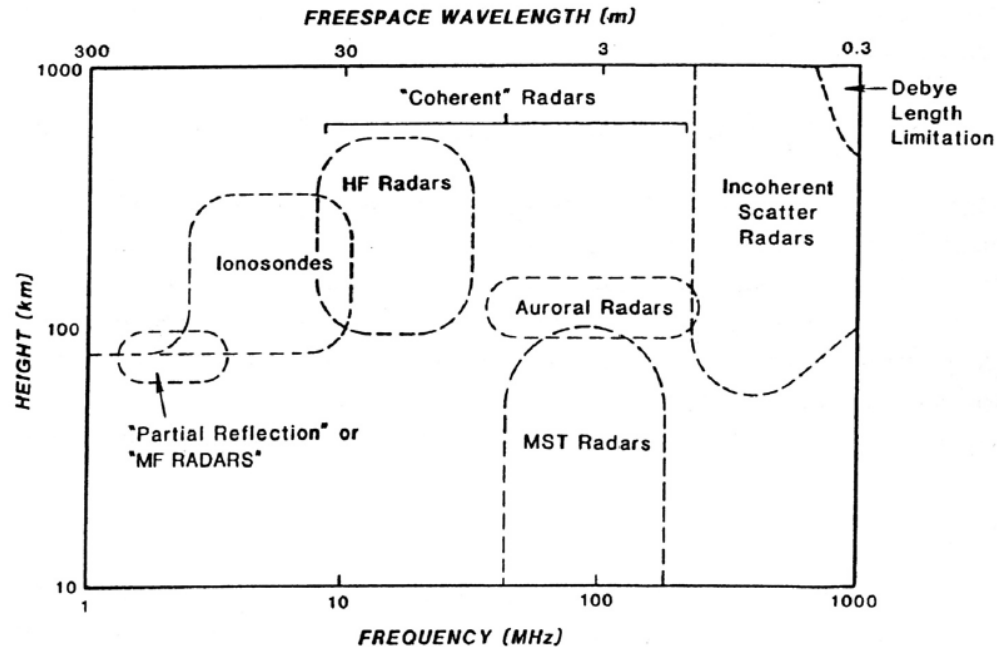

**Answer:** While the radar frequency needs to be higher than that of ionospheric plasma frequencies and irregularities, it should also be chosen with a wavelength greater than the Debye length. This becomes an issue at higher altitudes.



# The ionosphere

## Latitudinal variations

- **High-latitude ionosphere** (polar cap, cusp, auroral oval): intense electric fields mapping from the magnetosphere, particle precipitation, effects of magnetospheric substorms.
- **Mid-latitude ionosphere:** occasionally high-latitude electric fields may penetrate to mid-latitudes, effects of magnetic storms.
- **Low-latitude ionosphere:** small electric fields, high daytime conductivities due to solar radiation (equatorial electrojet).

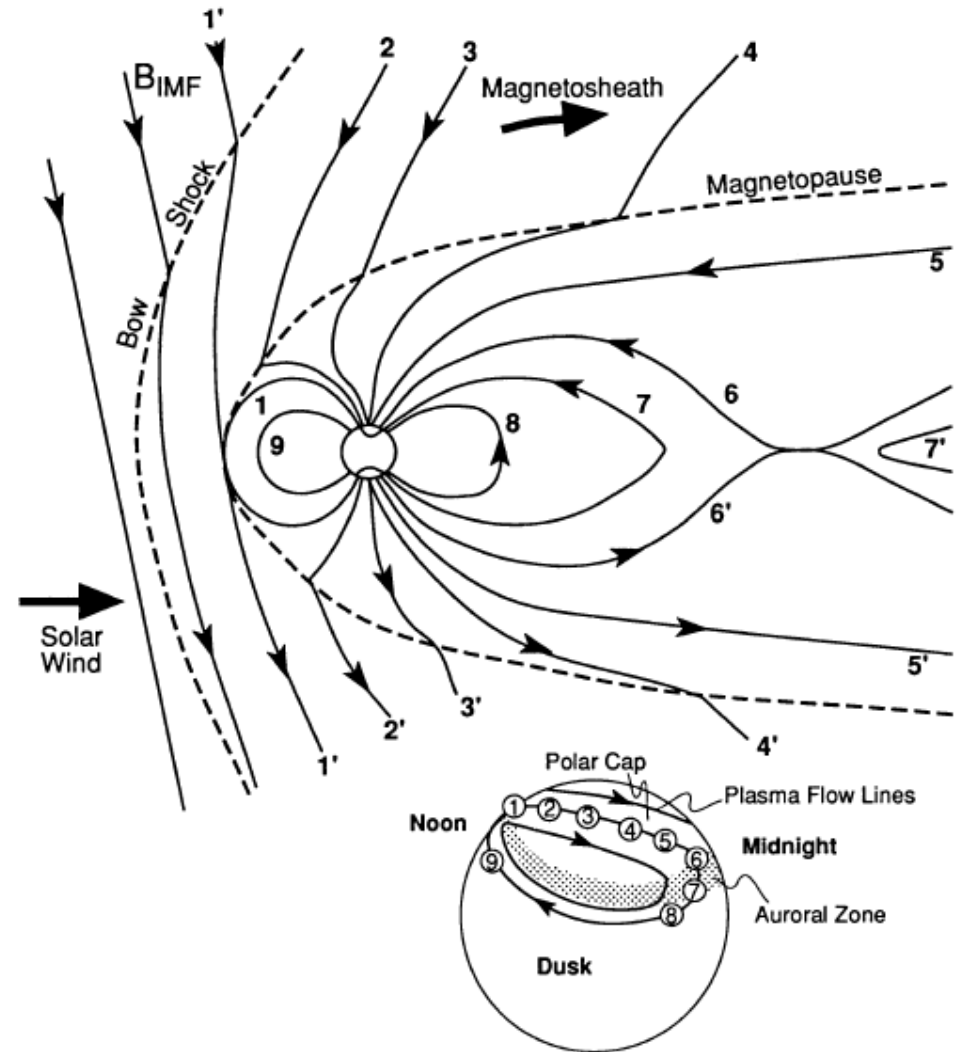

# The ionosphere

## D-region

- Small electron densities, large neutral densities
- Complex chemistry including ion production and recombination processes, also transport, that are not fully understood.

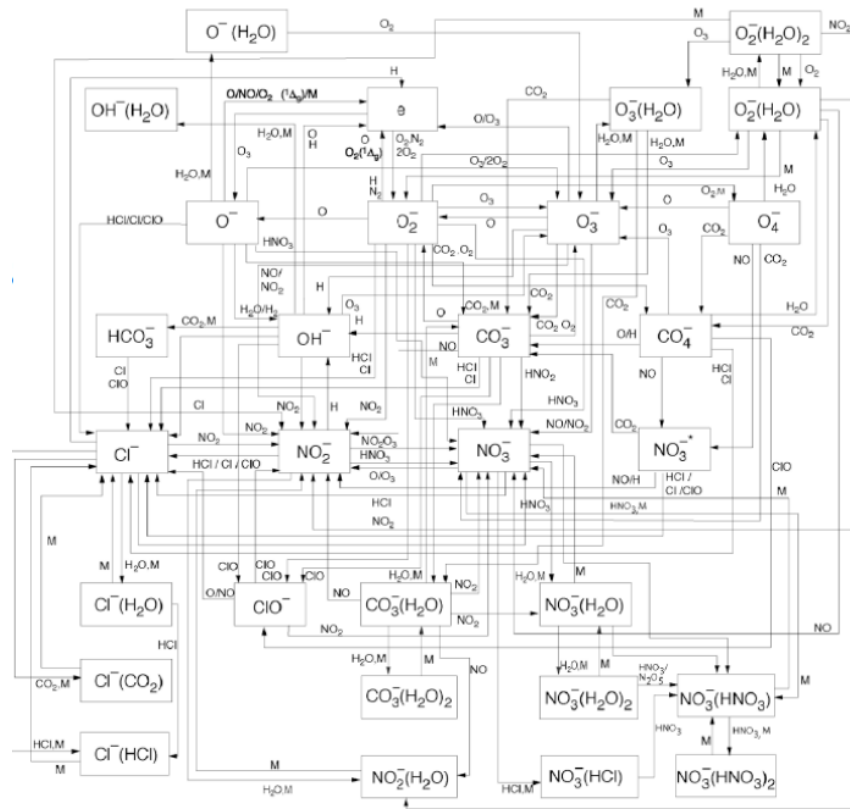

Figure: Sodankylä Ion Chemistry model (SIC), negative ions

# The ionosphere

## E-region

- Due to different collision and gyro frequencies for ions and electrons, electrical conductivities maximize in the E region and may be greatly enhanced due to auroral particle precipitation
- Horizontal currents flow in the E region

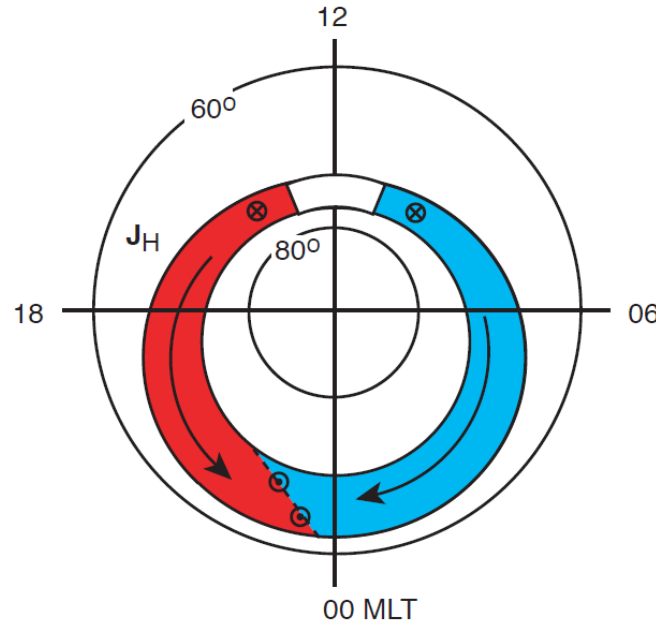

Figure: Hall currents within the auroral oval: eastward electrojet (red) and westward electrojet (blue)

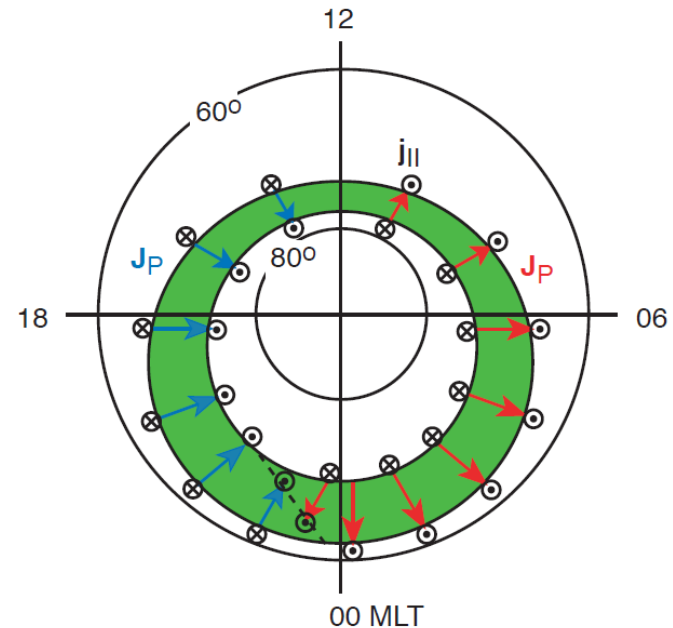

Figure: Pedersen and field-aligned currents within the auroral oval

# The ionosphere

## F-region

- Maximum electron densities occur at F-region maximum ( $h \sim 300$  km).
- Collisions with neutrals become sparse both for ions and electrons, hence both species drift with the same convection velocity of  $\mathbf{v} = \mathbf{E} \times \mathbf{B} / B^2$
- Ambipolar diffusion becomes important
- At high latitudes, ion outflows may take place and field-aligned currents flow

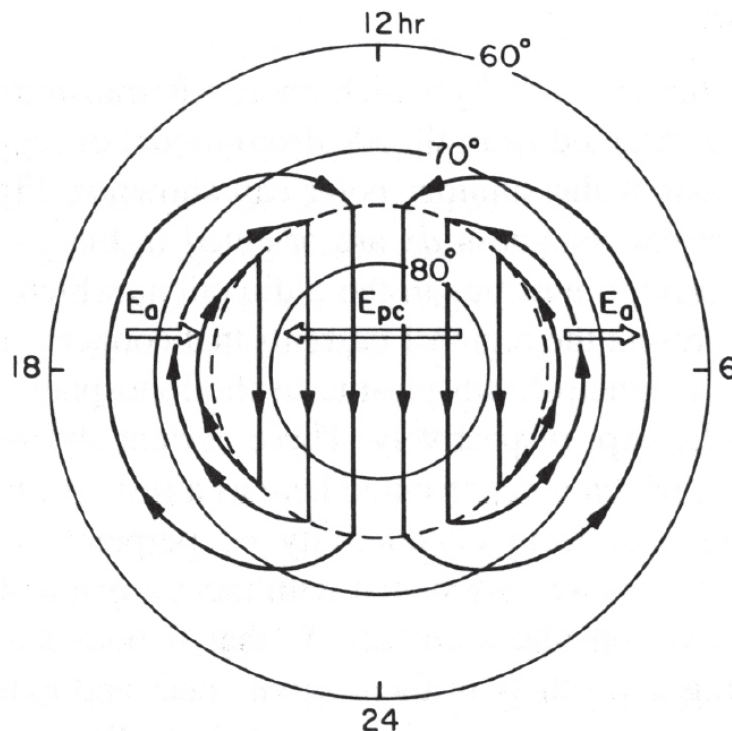
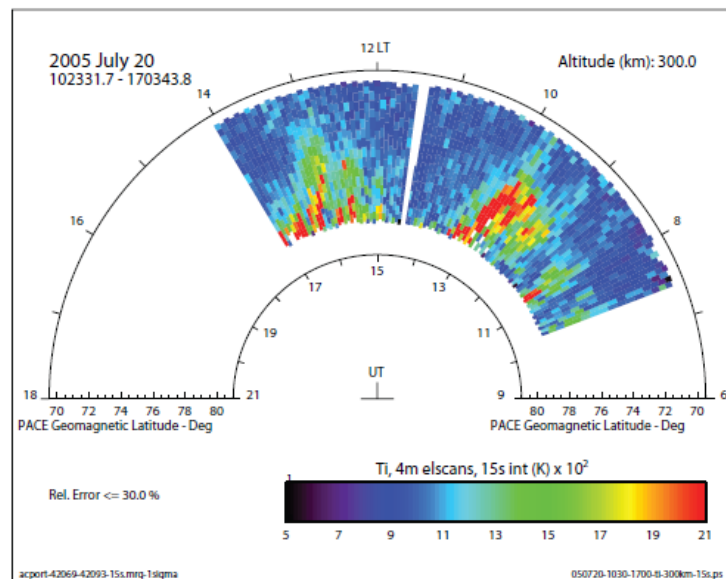
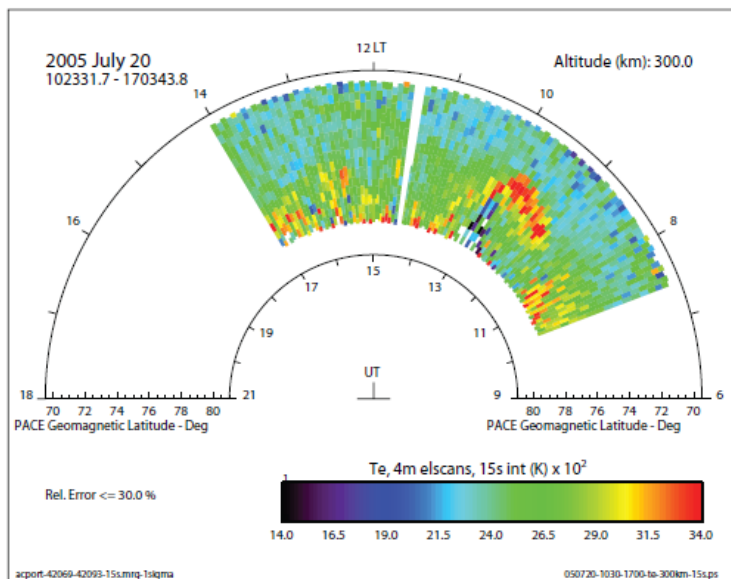
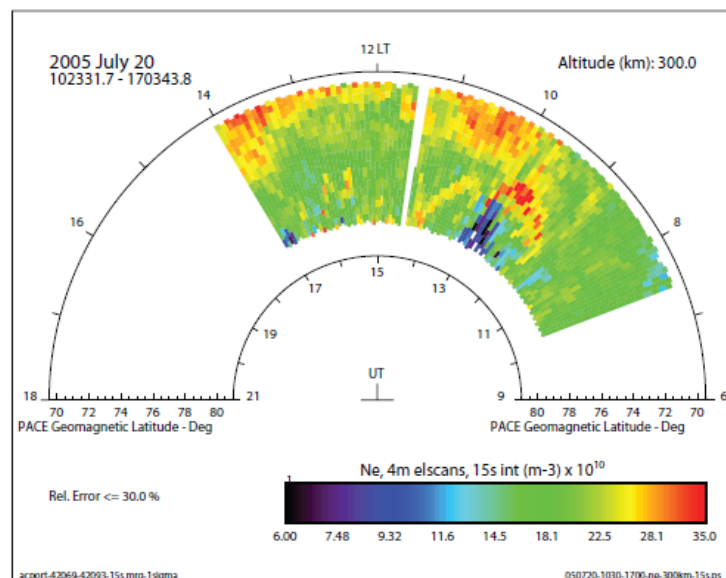
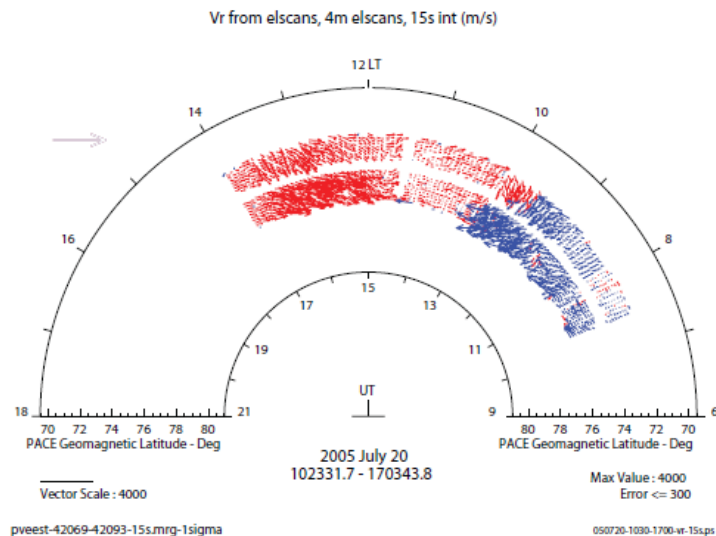

Figure: Plasma convection in the northern high latitude ionosphere and associated convection electric fields

# The ionosphere

## ISR example



# The ionosphere

## ISR example

Influx of particles and Joule heating (due to current flow)

Electron density enhancement

Convection reversal

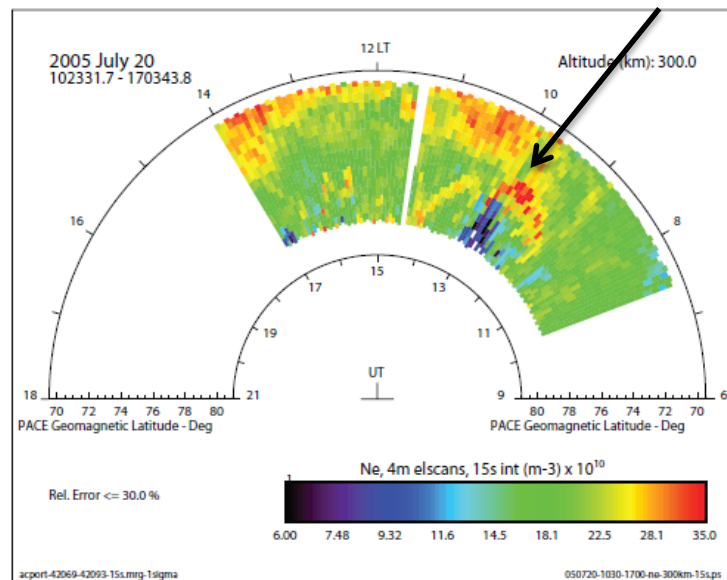
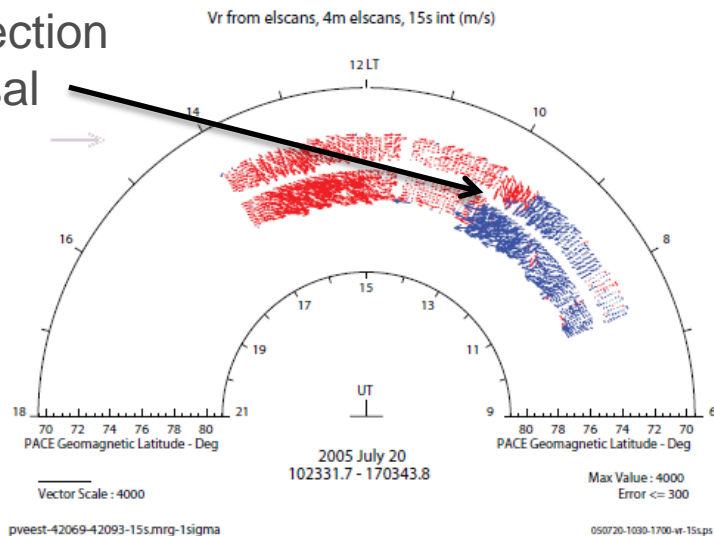

Electron temperature enhancement

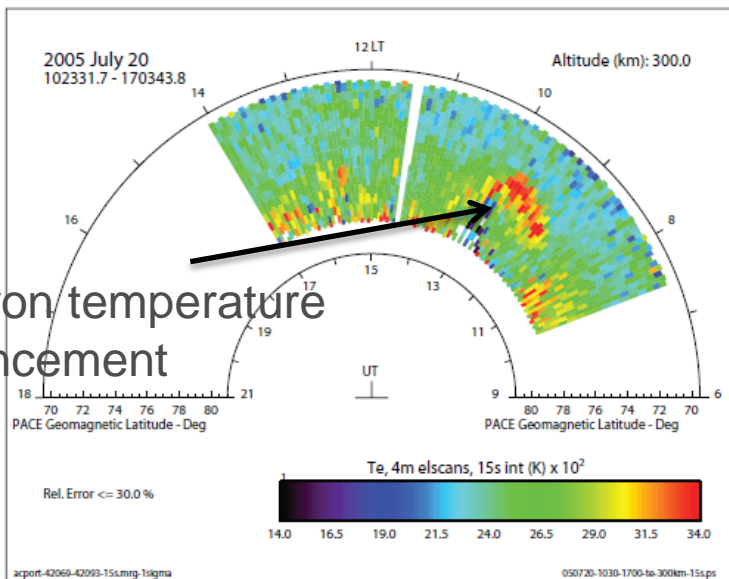

Ion temperature enhancement

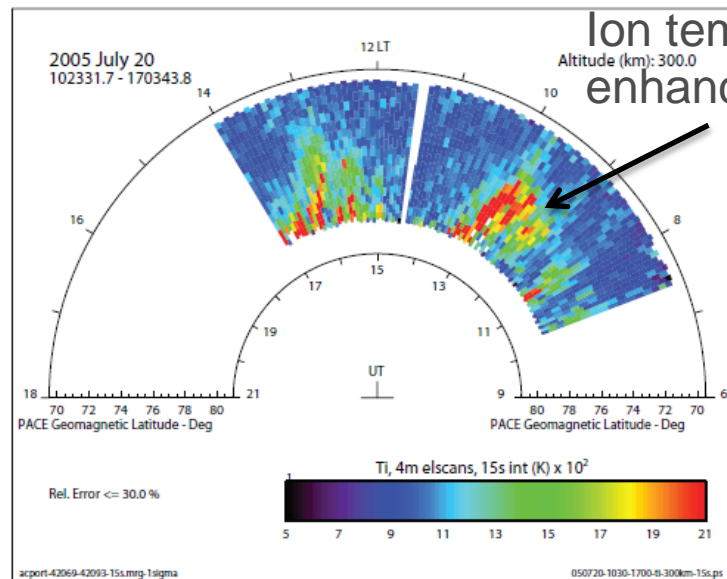

# Literature

- Brekke, A.: Physics of the Upper Atmosphere, John Wiley & Sons, 1997.
- Hunsucker, R. D. and J.K. Hargreaves, The High-Latitude Ionosphere and its Effects on Radio Propagation, Cambridge University Press, 2003
- Kelley, M. C.: The Earth's Ionosphere, Academic Press, 1989
- H. Risbeth and O. K. Garriot: Introduction to Ionospheric Physics, Academic Press, 1969
- Hargreaves, J. K., The solar-terrestrial environment, Cambridge University Press, 1992.